

MKT Series

907L/907T/908H

Valve nominal size

907L
908H 50 to 300mm

907T 50 to 400mm

Max. working pressure MPa

0 1.0 2.0

907L	1.0
907T 908H	2.0

Working temperature range °C

0 100

907L 907T 908H	NBR	80
907L	EPDM	100
907T 908H	EPDM	120

NK Nippon Kaiji Kyokai (907L)

Pressure distribution is indicated by colors. Flow speed is indicated by arrow size.

High pressure ← → Low pressure

MKT series

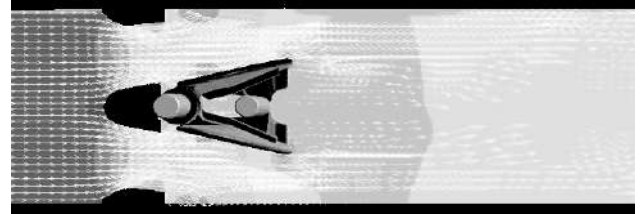

Conventional Model

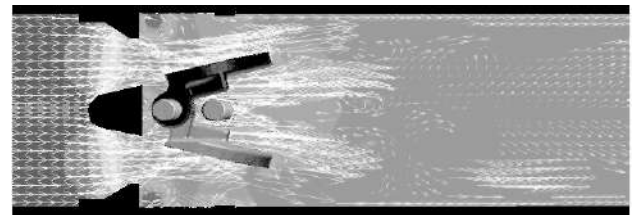

Prevention of chattering.

Check valve of a new generation that reduce piping space and allow direct attachment to a pump.

Features and Benefits

Prevents water hammer

The combination of a light, compact plates with a small moment of inertia and an optimized spring quickly stops the flow when the pump is turned off, preventing water hammer.

Direct installation to a reducer

Preventing chattering caused by fluid turbulence enables installing a check valve behind a reducer and a curved pipe. Straight pipe at upstream side is not necessary. Durability improved by decreasing vibration and noise.

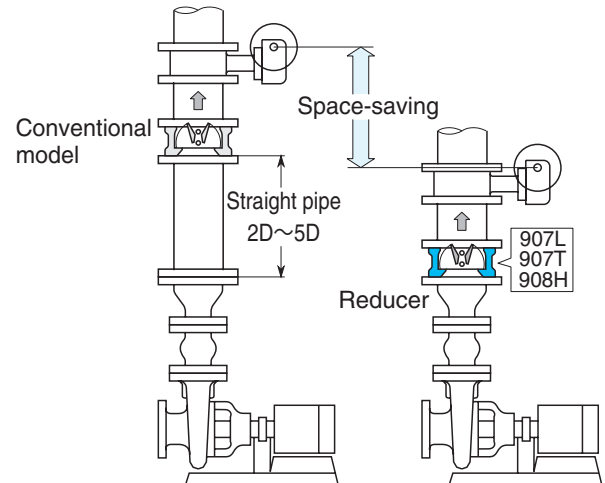

Bearing

Raised resonance frequency by optimizing the clearance of bearing, in order to decrease sympathetic vibration of plates while operating

Wing shaped plates with rib

Lightweight plates reduce moment of inertia, improving performance of preventing water hammer. Wing shaped plates reduce eddy, reducing vibration of plate.

Centering

Centering of valve body and flange can be performed among all applicable flanges, simplifying piping work.

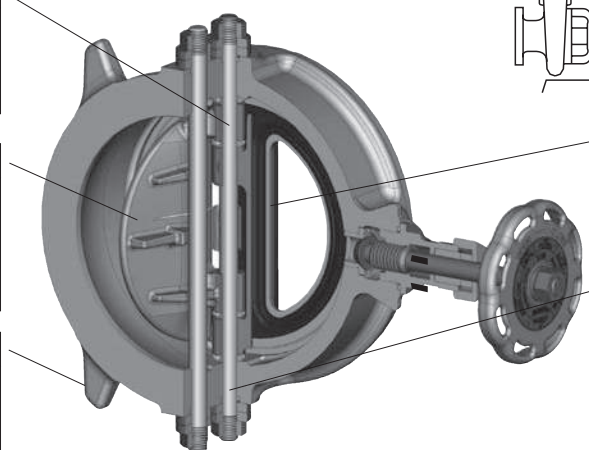

Rubber seat

Lip seal improved sealing performance of back pressure at low hydraulic head.

Shaft pins

Either side of shaft pin is fixed with nuts and plugs in order to prevent vibration. Washers absorb expanded/contracted shaft pins caused by pressure and temperature fluctuation, also mitigate loosen nuts and overstressed pins, improving durability (907L).

*1 These are common features of 907L, 907T and 908H in case of any specific model is not indicated.

*2 Drawing shows 907L. Structure of bypass differs from 907T and 908H.

Standard Specifications

		907L	907T	908H
Valve nominal size ^{※1}		50mm to 300mm	50mm to 400mm ^{※1}	50mm to 300mm ^{※1}
Face-to-face dimensions		Manufacturer standard Refer to dimension "L".		
Flange accommodation		JIS 5K, 10K	JIS 10K, 16K, 20K ASME Class125, Class150	
Max. working pressure ^{※2}		1.0 MPa	2.0 MPa	
Seat leakage		Tight shut (JIS B 2003:2013 Rate A) Pressure more than "Required differential pressure" is needed.		
Required differential pressure ^{※3}		0.04 MPa (Hydraulic head 4 m) or more		
Average velocity inside pipe		6 m/s	10 m/s	
Chattering prevention		YES Directly installable to a reducer and a curved pipe	YES Directly installable to a reducer, a curved pipe and a pump	
Working temperature range		EPDM : -20 ~ 100 °C NBR : -10 ~ 80 °C	EPDM : -20 ~ 120 °C NBR : -10 ~ 80 °C	
Working temperature in continuous use		EPDM : 0 ~ 70 °C NBR : 0 ~ 60 °C	EPDM : 0 ~ 100 °C NBR : 0 ~ 60 °C	
Standard materials	Body ^{※5}	FC250 Cast iron	A536 Gr.65-45-12 Ductile iron	A351 CF8 Stainless steel
	Plate	SCS13 Stainless steel	A351 CF8 stainless steel	
	Seat ring ^{※6,7}	EPDM (Option: NBR) Vulcanized to valve body		
	Shaft pins	304 stainless steel		
	Spring	304 stainless steel		
Test pressure	Body shell test	1.5 MPa (hydraulic)	3.0 MPa (hydraulic)	
	Seat leakage High pressure Low pressure	1.1 MPa (pneumatic) 0.04 MPa (pneumatic)	2.2 MPa (hydraulic) 0.04 MPa (pneumatic)	
Accessories ^{※1,8}		Standard : Bypass valve (Except for 350 and 400mm) Option : High torque spring, low torque type (standard spring installed unless otherwise specified)		
Pipe gasket		Required Use two commercially available gaskets per valve, which is appropriate for flange standard and fluid condition.		
Fluid types ^{※7,8,9,10}		Water	Water, air	
Coating		Urethane coating (Tomoe green)		—

- ※1 907T 350mm and 400mm are made to order. (Bypass valve is not installed.)
A rubber sleeve is inserted to 907T/908T 250mm and upper size. Pressure loss increases compared to the one without a rubber sleeve.
- ※2 MKT Series cannot be used under negative pressure. Do not install it underwater or underground.
- ※3 In case of 907L, required differential pressure differs depending on installing condition and spring selection. Please refer to spring selection table.
- ※4 "Working temperature in continuous use" stands for the temperature continuously kept for over one hour, provided that a fluid is not frozen inside.
- ※5 Chemical treatment for rust prevention is applied to non-coated part of 907L/907T. This treatment may cause discoloration of surface to white or reddish brown. This does not affect product quality.
- ※6 EPDM seat ring is recommended in case of using a chemical containing calcium for maintenance. In case a fluid containing solid and adhesive material, 903L, 901C and 906C is recommended.
- ※7 EPDM seat ring can not be used for oil or a fluid containing oil. A fluid containing chlorine can accelerate damage to rubber seat ring, depending on density and temperature of a fluid. Please consult us for detail.
- ※8 As parts of bypass for 907L are made of copper alloy, a fluid which corrodes copper alloy such as acetylene, ammonia and sulfur can not be used. Copper alloy is not used for components of 907H/908H which a fluid contacts.
- ※9 A fluid containing alkali and acid can weaken bond of seat ring, please consult us for detail.
- ※10 MKT Series can not be used for a viscous fluid or a fluid containing powder. In case of gas, please check spring selection table for installing condition.

Select valve according to fluid and installing condition. Incorrect valve selection can cause vibration and abnormal noise.
Please refer to spring selection table and instruction manual before use.

Butterfly Valve
TRITEC
TT2
334A
344Q
302A/303Q
304A/304Q
304YA
302Y/304Y
304M (HLV)
507V/508V
DTM
846T/847T/847Q
841T/842T
700Z
700G/704G/705G
72WG/72SG/72LG
731P/732P/732Q/752W
731R
700E/700K/700S
704G/722F/720F
227P
907T/908H (MKT)
903L/901C/905C (Bata-check)

MKT Selection Criteria

1.0MPa 907L

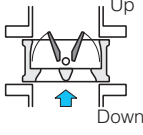
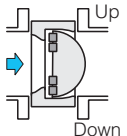
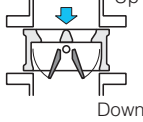
Flow Direction	Fluid	Condition	Min. differential pressure (MPa)	Size (mm)	Spring
Up flow 	Liquid (Clean water)	The valve should be installed directly after the following: - a reducer which is 3 sizes smaller than a valve - a curved pipe - a straight pipe	0.02	50~300	High torque
			0.04		Standard
	Gas	Forward direction, inlet pressure 0.1MPa or more	0.04		Low torque specification (no spring)
Horizontal layout 	Liquid (Clean water)	The valve should be installed directly after the following: - a reducer which is 2 sizes smaller than a valve - a curved pipe - a straight pipe	0.04	50~300	High torque
			0.06	50~200	Standard
Down flow ^{*1} 			0.1	50~150	High torque

※ Equivalent or more pressure shown in the table is needed for sealing performance. When inlet pressure remains, differential pressure may not be maintained. Especially in case of down flow, inlet pressure easily remains.
 ※ Inlet pressure in a forward direction needs to be higher than cracking pressure and lower than max. working pressure.
 ※ Do not use under the condition other than above to avoid vibration, abnormal noise, damage, and leakage.

2.0MPa 907T/908H

Flow Direction	Fluid	Condition	Min. differential pressure (MPa)	Size (mm)	Spring
Up flow 	Liquid (Clean water)	The valve should be installed directly after the following: - a reducer which is 3 sizes smaller than a valve - a curved pipe - a straight pipe	See Table A	50~400	Low torque
			0.5~2.0		Standard
	2.0~10	Low torque			
	Gas	Differential pressure 0.1~2.0 Mpa	10~50		Low torque
Horizontal layout 	Liquid (Clean water)	The valve should be installed directly after the following: - a reducer which is 2 sizes smaller than a valve - a curved pipe - a straight pipe	2.0~10	50~200	Standard
				250~400	High torque
Down flow ^{*1} 			0.1~5.0	50~200	High torque

Table A Allowed velocity range

Nominal size	Allowed velocity
50A	1.2~10 m/s
65A	
80A	
100A	
125A	1.6~10 m/s
150A	
200A	
250A	2.2~10 m/s
300A	

※ In case of down flow, there is possibility of leakage depending on condition when checking.
 ※ If possible, avoid installing directly after a reducer. Install before a reducer.
 ※ Do not use under the condition other than above to avoid vibration, abnormal noise, damage, and leakage.
 ※ All 907T/908H over 250mm will be attached rubber sleeve.

907L Expanded view of components

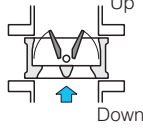
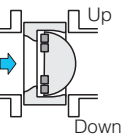
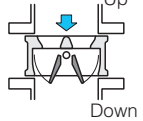
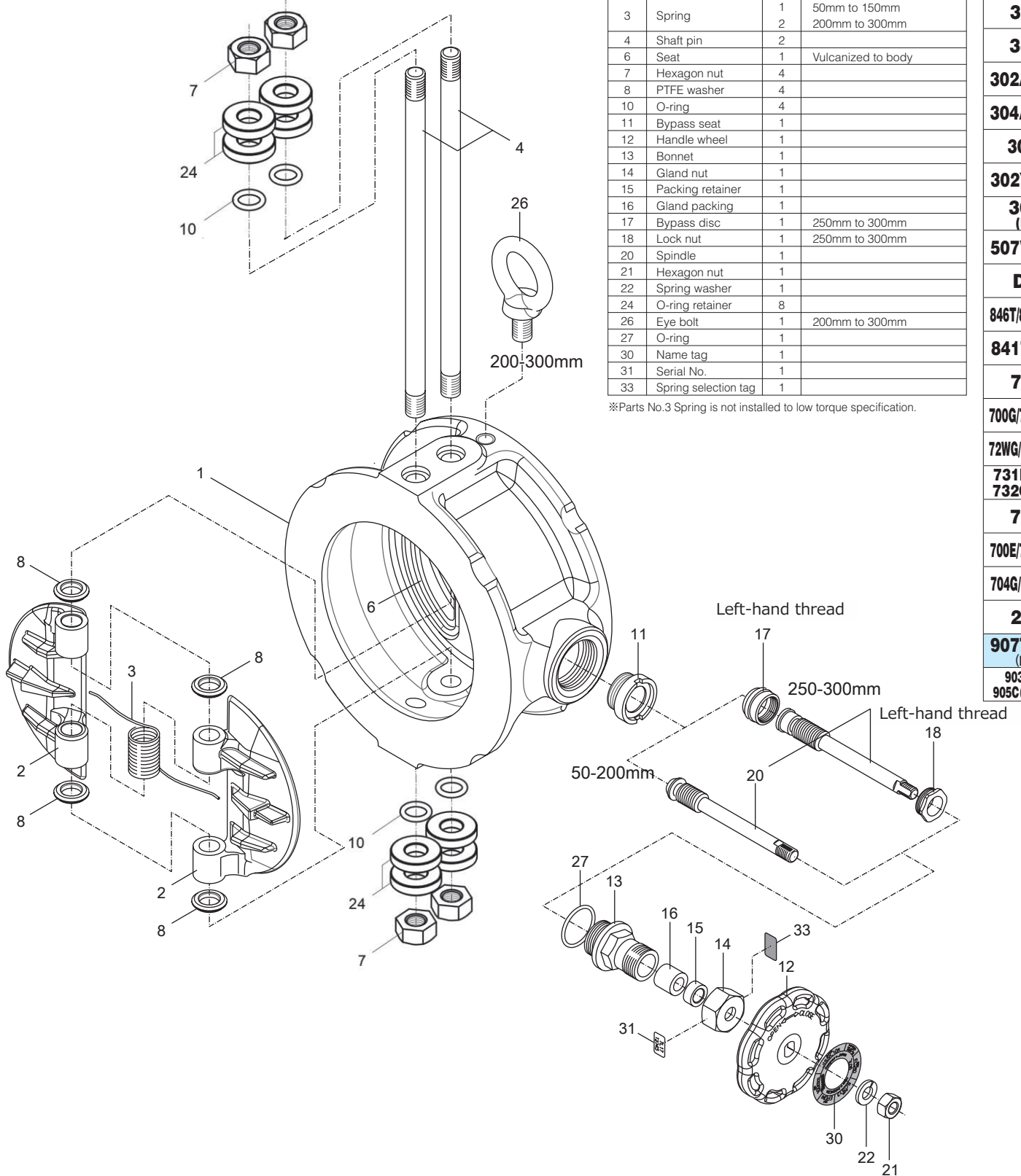

907L Parts list

No.	Description	Q'ty	Remarks
1	Body	1	
2	Plate	2	
3	Spring	1	50mm to 150mm
		2	200mm to 300mm
4	Shaft pin	2	
6	Seat	1	Vulcanized to body
7	Hexagon nut	4	
8	PTFE washer	4	
10	O-ring	4	
11	Bypass seat	1	
12	Handle wheel	1	
13	Bonnet	1	
14	Gland nut	1	
15	Packing retainer	1	
16	Gland packing	1	
17	Bypass disc	1	250mm to 300mm
18	Lock nut	1	250mm to 300mm
20	Spindle	1	
21	Hexagon nut	1	
22	Spring washer	1	
24	O-ring retainer	8	
26	Eye bolt	1	200mm to 300mm
30	Name tag	1	
31	Serial No.	1	
33	Spring selection tag	1	

※Parts No.3 Spring is not installed to low torque specification.

Butterfly Valve
TRITEC
TT2
334A
344Q
302A/303Q
304A/304Q
304YA
302Y/304Y
304M (HLV)
507V/508V
DTM
846T/847T/847Q
841T/842T
700Z
700G/704G/705G
72WG/72SG/72LG
731P/732P/732Q/752W
731R
700E/700K/700S
704G/722F/720F
227P
907T/908H (MKT)
903L/901C/905C (Bata-check)

907T/908H Expanded view of components

■ 907T/908H Parts list

No.	Description	Q'ty	Remarks
1	Body	1	
2L	Left plate	1	
2R	Right plate	1	
3	Spring	1	50mm to 150mm
		2	200mm and over
4	Hinge pin	1	
5	Stop pin	1	
6	Seat	4	Vulcanized to body
7	Hexagon nut	4	
8	PTFE washer A	2	
9	PTFE washer B	4	
10	Eye bolt	1	150mm and over
11	O-ring	4	
12	Handle wheel	1	50mm to 300mm
13	Lock bolt	1	50mm to 300mm
14	Stopper	1	50mm to 300mm
15	Hex. socket set screw	2	50mm to 300mm
16	O-ring	1	50mm to 80mm
		2	100mm to 300mm
19	Name plate	1	
19b	Serial No.	1	
19c	Spring selection tag	1	
20	Spindle	1	50mm to 300mm
21	Hexagon nut	1	50mm to 300mm
23	Collar	1	50mm to 300mm
24	O-ring cover	8	
29	Spring washer	1	50mm to 300mm
30	Bearing	4	
51	Bypass seat	1	50mm to 300mm
99	Rubber sleeve	1	250mm and over

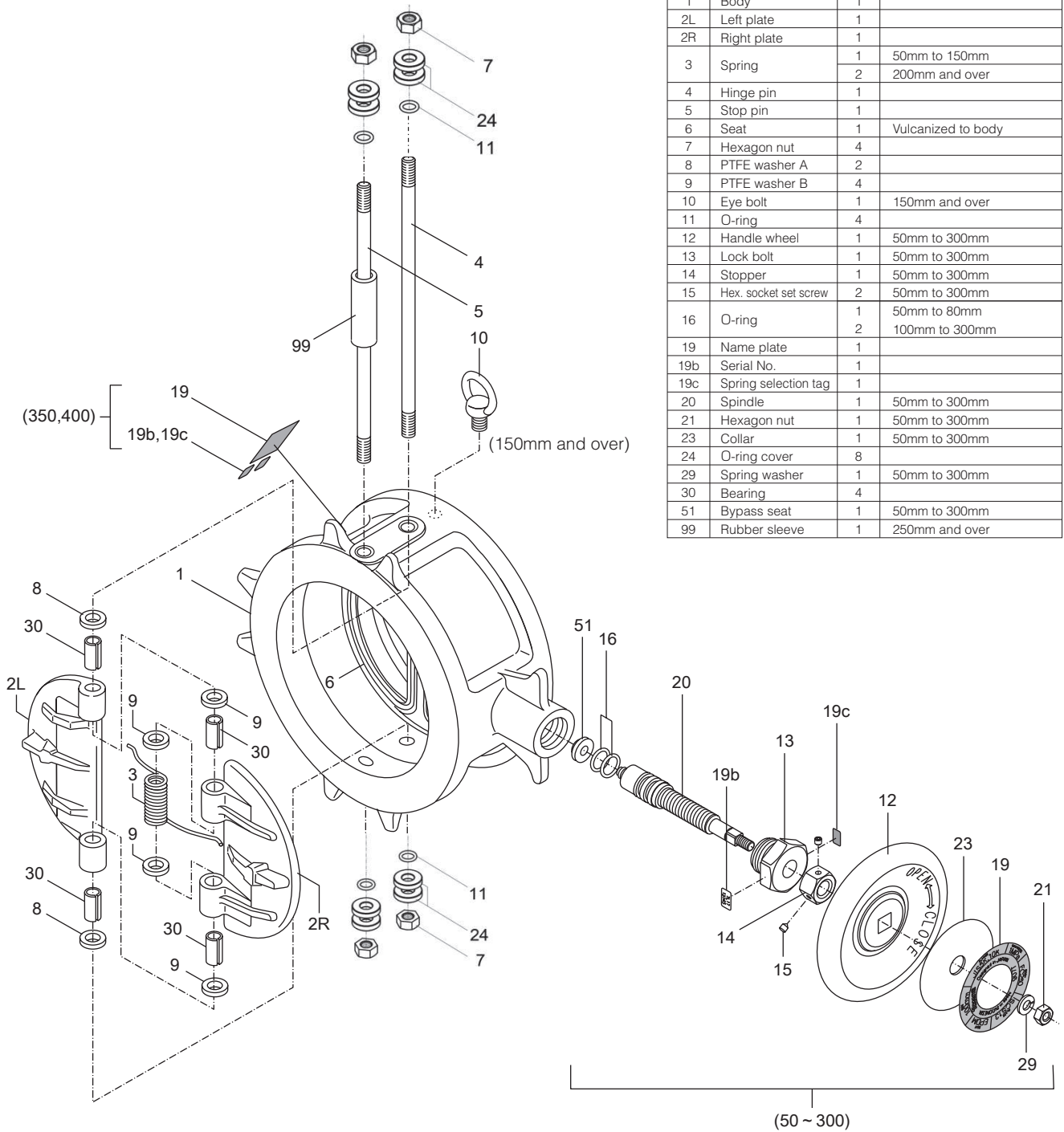

MKT Dimension

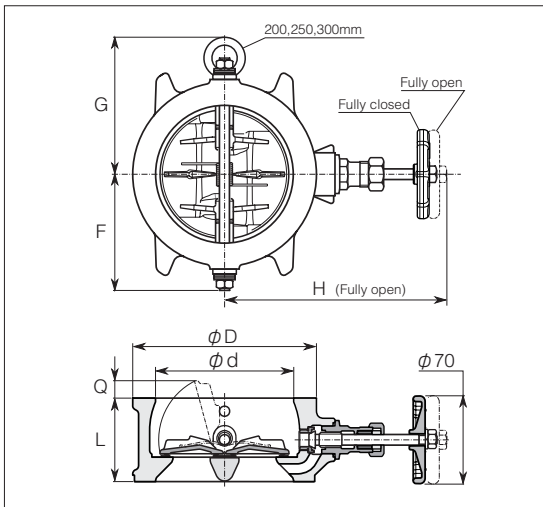

907L

Nominal size		Dimension(mm)								Approx. Mass (kg)
mm	inch	ϕd	L	ϕD	H	F	G	Q		
50	2	61	56	90	149	59	—	0	1.8	
65	2 1/2	74	56	114	157	72	—	6	2.5	
80	3	87	60	130	163	84	—	9	3.2	
100	4	109	66	145	176	92	—	16	4.0	
125	5	140	70	180	190	110	—	27	5.8	
150	6	163	76	210	204	125	—	36	8.3	
200	8	214	95	265	230	160	169	45	15	
250	10	268	108	320	285	187	197	60	24	
300	12	316	144	373	310	221	232	58	39	

※ The drawing on the left is representative example. For detail, please refer to specifications.

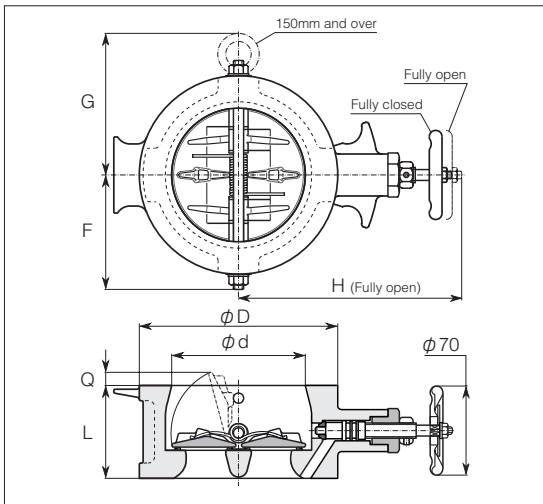

907T/908H

Nominal size		Dimension(mm)								Approx. Mass (kg)	
mm	inch	ϕd	L	ϕD	H	F	G	Q	907T	908H	
50	2	58	60	101	131	66	—	0	2.5	2.7	
65	2 1/2	74	67	121	138	76	—	0	3.5	3.7	
80	3	87	73	131	145	84	—	0	4.4	4.7	
100	4	105	73	156	176	97	—	10.5	5.9	6.2	
125	5	134	86	187	189	112	—	13.5	8.7	9.2	
150	6	160	98	217	202	130	142	20	12	13	
200	8	210	127	267	228	160	167	24.5	22	23	
250	10	256	146	330	272	194	198	30	36	38	
300	12	306	181	375	298	217	229	23	53	56	
350 ^{※1}	14	341	184	420	255 ^{※2}	245	252	38	72	—	
400 ^{※1}	16	391	191	483	282 ^{※2}	277	283	55	100	—	

※ The drawing on the left is representative example. For detail, please refer to specifications.

※1 907T 350mm and 400mm are made to order.

※2 Bypass valve is not installed.

Butterfly Valve

TRITEC

TT2

334A

344Q

302A/303Q

304A/304Q

304YA

302Y/304Y

304M

(HLV)

507V/508V

DTM

846T/847T/847Q

841T/842T

700Z

700G/704G/705G

72WG/72SG/72LG

731P/732P/732Q/752W

731R

700E/700K/700S

704G/722F/720F

227P

907T/908H

(MKT)

903L/901C/905C

(Bata-check)

MKT Pressure loss vs. Flow rate

907L

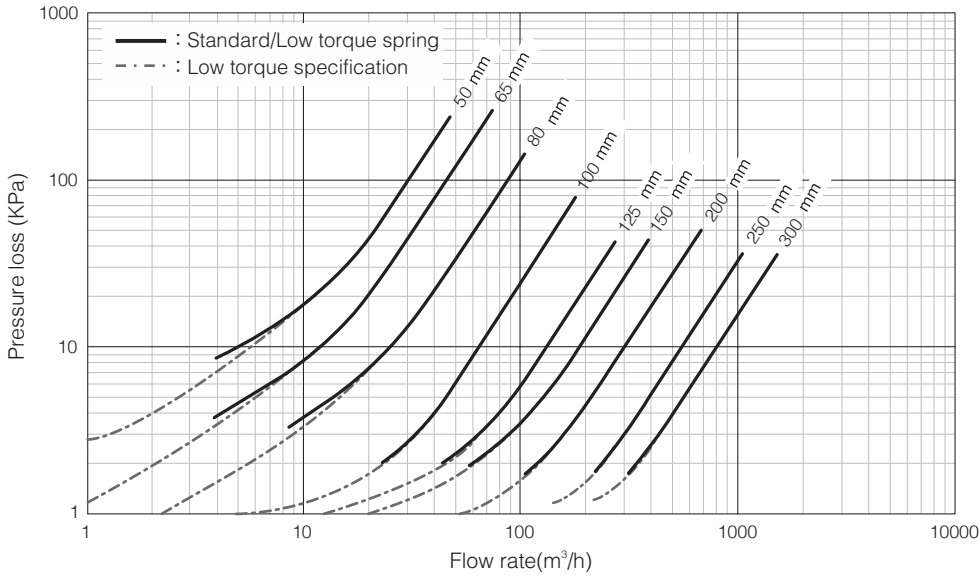

Nominal size (mm)	Cv value (-)	Resistance coefficient ζ (-)
50	35	14
65	52	15
80	101	7.8
100	235	4.3
125	485	2.4
150	684	2.4
200	1100	2.9
250	2030	2.0
300	2930	2.0

907T/908H

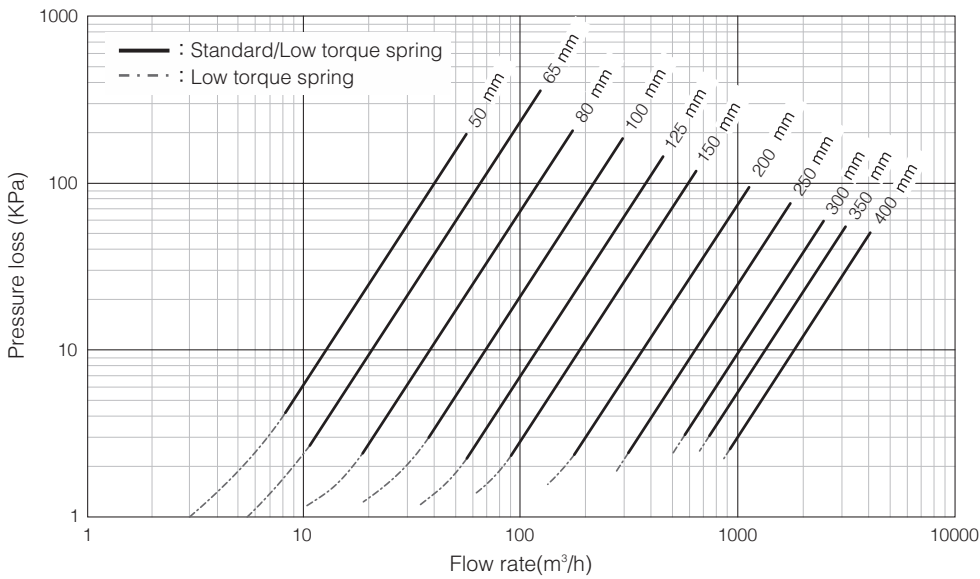

Nominal size (mm)	Cv value (-)	Resistance coefficient ζ (-)
50	50	6.6
65	73	7.6
80	138	4.2
100	251	3.8
125	435	3.0
150	685	2.4
200	1340	2.0
250	2097	1.9
300	3572	1.4
350	4900	1.2
400	6700	1.1

※ Both two tables above show values in case of standard/low torque spring. In case of high torque spring and low torque spring, please consult our sales staff.

MKT Cracking pressure (opening pressure) & Diameter of piping

907L Cracking pressure

Flow direction Spring Nominal size	Horizontal		Vertical(up flow)		
	Standard spring	High torque spring	Low torque specification	Standard spring	High torque spring
mm	KPa	KPa	KPa	KPa	KPa
50	5.7	5.7	0.61	6.8	6.8
65	2.8	5.1	0.66	3.8	6.1
80	2.7	3.2	0.62	3.3	3.9
100	1.3	2.9	0.69	2.1	3.7
125	1.4	2.9	0.76	2.0	3.7
150	1.1	2.9	0.82	2.0	3.7
200	0.70	2.8	0.94	1.8	3.7
250	—	2.1	1.2	1.8	3.2
300	—	2.0	1.3	1.8	3.2

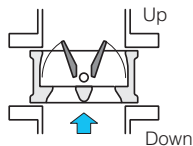
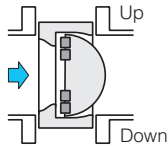

907T/908H Cracking pressure

Flow direction Spring Nominal size	Horizontal		Vertical(up flow)		
	Standard spring	High torque spring	Low torque spring	Standard spring	High torque spring
mm	KPa	KPa	KPa	KPa	KPa
50	3.0	5.1	0.88	4.2	6.8
65	1.8	3.8	0.74	2.7	5.1
80	1.5	3.2	1.2	2.4	4.5
100	1.8	3.2	1.3	3.0	4.7
125	1.1	2.2	1.3	2.3	3.5
150	1.1	2.1	1.4	2.4	3.6
200	0.75	1.4	1.6	2.4	3.1
250	—	1.4	1.9	2.4	3.4
300	—	1.2	2.5	3.1	3.7
350	—	0.95	2.6	3.1	3.5
400	—	0.95	2.3	2.5	3.2

- Cracking pressure (opening pressure) is minimum pressure that allows a fluid to flow stably in a forward direction. Flow would not be stable even a fluid flows under this pressure.
- Internal diameter of piping shall be equal to Pi or over. In case of lined pipe, take lining into accounts when you check internal diameter. JIS G3452 SGP, JIS G3454 Sch60 and under, JIS G3459 Sch40 and under and VP pipe are applicable. In addition, JIS G3454, JIS G3459 "Sch80" are also applicable in case of 907T/908H.
- Internal diameter of gaskets contact part needs to be smaller than maximum internal diameter (Fi). JIS B2220 SOP, SOH, WN, IT, SW and TS (resin pipe) are applicable.
- In case of loose flange, internal diameter of flat collar (except for the rounded part) needs to be smaller than maximum internal diameter (Fi). JIS B2309 and SAS 363:2018 are applicable.

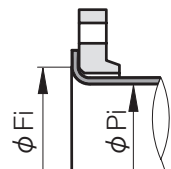

Loose flange

907L Internal diameter of piping

Nominal size	Minimum internal diameter of piping	Maximum internal diameter
	Pi	Fi
mm	mm	mm
50	41	63
65	55	86
80	67	98
100	91	117
125	121	144
150	145	171
200	190	227
250	239	274
300	286	332

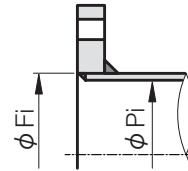

907T/908H Internal diameter of piping

Nominal size	Minimum internal diameter of piping	Maximum internal diameter
	Pi	Fi
mm	mm	mm
50	35	63
65	46	86
80	56	98
100	81	117
125	99	144
150	123	171
200	157	227
250	205	274
300	223	332
350	259	367
400	311	413

Butterfly Valve
TRITEC
TT2
334A
344Q
302A/303Q
304A/304Q
304YA
302Y/304Y
304M (HLV)
507V/508V
DTM
846T/847T/847Q
841T/842T
700Z
700G/704G/705G
72WG/72SG/72LG
731P/732P/732Q/752W
731R
700E/700K/700S
704G/722F/720F
227P
907T/908H (MKT)
903L/901C/905C (Bata-check)

MKT Applicable pipe list in case of A

Type	Nominal size		SGP	Sch20	Sch40	Sch10S	Sch20S
	mm	inch					
907L 907T 908H	50	2	○	○	○	○	○
	65	2 1/2	○	○	○	○	○
	80	3	○	○	○	○	○
	100	4	○	○	○	○	○
	125	5	○	○	○	○	○
	150	6	○	○	○	○	○
	200	8	○	○	○	○	○
	250	10	○	○	○	○	○
907T	300	12	○	○	○	○	○
	350	14	○	○	○	○	○
	400	16	○	○	○	○	○

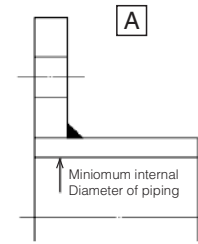

Remark : ○ : Installation possible, — : No standard

MKT Applicable pipe list in case of B

Type	Nominal size		SGP	Sch20	Sch40	Sch10S	Sch20S
	mm	inch					
907L 907T 908H	50	2	○	○	○	○	○
	65	2 1/2	○	○	○	○	○
	80	3	○	○	○	○	○
	100	4	○	○	○	○	○
	125	5	○	○	○	○	○
	150	6	○	○	○	○	○
	200	8	○	○	○	○	○
	250	10	○	○	○	○	○
907T	300	12	○	○	○	○	○
	350	14	○	○	○	○	○
	400	16	○	○	○	○	○

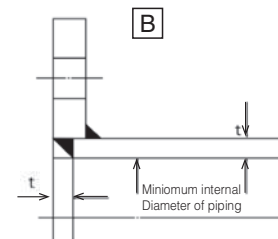

Remark : ○ : Installation possible, — : No standard

MKT Piping bolt and nut sizes

Type	Nominal size		JIS 5K	JIS 10K
	mm	inch		
907L	50	2	4-M12×110×40	4-M16×120×40
	65	2 1/2	4-M12×110×40	4-M16×120×40
	80	3	4-M16×115×40	8-M16×120×40
	100	4	8-M16×125×40	8-M16×130×40
	125	5	8-M16×130×50	8-M20×140×50
	150	6	8-M16×140×50	8-M20×150×50
	200	8	8-M20×170×50	12-M20×170×50
	250	10	12-M20×190×50	12-M22×190×50
300	12	12-M20×220×50	16-M22×230×50	

Type	Nominal size		JIS 10K	JIS 16K/20K	ASME class 125/150
	mm	inch			
907T 908H	50	2	4-M16×120×35	8-M16×120×35	4-U5/8-11×125×35
	65	2 1/2	4-M16×130×40	8-M16×130×40	4-U5/8-11×140×40
	80	3	8-M16×135×40	8-M20×150×50	4-U5/8-11×150×50
	100	4	8-M16×135×40	8-M20×150×50	8-U5/8-11×150×50
	125	5	8-M20×160×50	8-M22×170×50	8-U3/4-10×165×50
	150	6	8-M20×175×50	12-M22×185×50	8-U3/4-10×180×50
	200	8	12-M20×205×50	12-M22×220×50	8-U3/4-10×215×50
	250	10	12-M22×225×50	12-M24×245×60	12-U7/8- 9×240×60
	300	12	16-M22×265×50	16-M24×285×60	12-U7/8- 9×280×60
	350	14	16-M22×265×50	16-M30(P3)×305×60	—————
	400	16	16-M24×280×60	16-M30(P3)×320×60	—————

- ※ Material: SS400 unichrome plating
- ※ Length of bolt is calculated based on thickness of JIS B 2220:2012 steel pipe flange (except for 10K thin type), size of JIS B1181:2014 style 1 hexagon nut and 3mm thickness of gaskets.
- ※ Do not use rusted, damaged or deformed bolt or nut. Lubricate screws enough.
- ※ Number of bolt shown above is needed for one piece of valve.

Setting bolts: 4 - M30 × 95 × 65
(Hexagon bolts)

N
M
L
S

Setting bolts (Hexagon bolts)

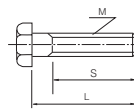

MKT Gasket

Commercially available gaskets which are appropriate for flange standard and fluid condition can be used. Our recommendation is as follows:

- Size : JIS B 2404 (size of flange used)
- Type : Seat gaskets (Non-metal flat gasket)
- Shape : Ring gaskets
- Material : JIS R 3453 joint sheet / Reinforced rubber / RPTFE
- Thickness : 1.5 to 3mm (3mm is recommended.)
- Quantity : 2 pieces/valve

- ※ In case of resin flange, use gaskets which is recommended by flange manufacturer.
- ※ 907T/908H: Perform centering appropriately so that a gasket does not distract the bypass passage. 907L: The bypass passage runs inside of valve body; a gasket does not distract the bypass passage. Perform centering appropriately so that a gasket at outlet side does not distract plates. Gaskets tend to protrude inner side due to pressure; especially they are made of rubber. Internal diameter of gaskets shall be the same as seat gasket shown in JIS B 2404.
- ※ 65A suits both new and old JIS.

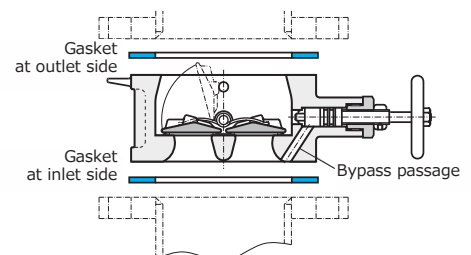

Butterfly Valve
TRITEC
TT2
334A
344Q
302A/303Q
304A/304Q
304YA
302Y/304Y
304M (HLV)
507V/508V
DTM
846T/847T/847Q
841T/842T
700Z
700G/704G/705G
72WG/72SG/72LG
731P/732P/732Q/752W
731R
700E/700K/700S
704G/722F/720F
227P
907T/908H (MKT)
903L/901C/905C (Bata-check)