

903L

901C

905C

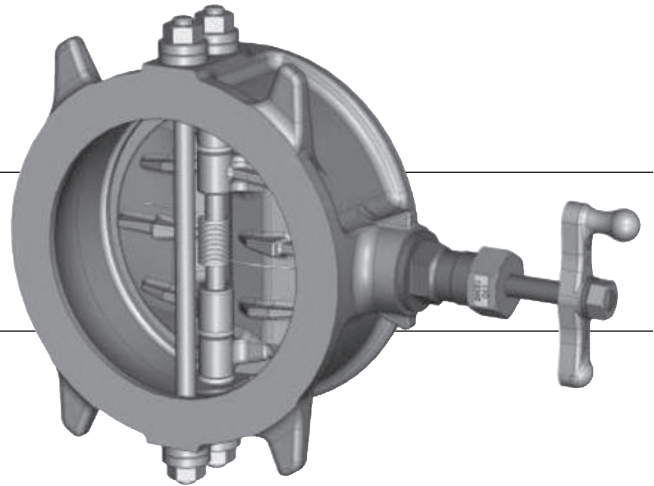

Valve nominal size

903L 50 to 300mm

901C 350 to 400mm

905C 50 to 400mm

Max. working pressure	MPa		
	0	1.0	2.0
903L 901C		1.0	
905C			3.0

Working temperature range	°C	
	0	100
903L 901C	-10	80
903L 905C	-20	100
901C	-5	120

NK Nippon Kaiji Kyokai (903L, 901C)

Features and Benefits

Lightweight and compact Check Valve protects piping lines from water hammer with its instant response

- Dual plates quickly shut when water flow stops, prevent water hammer and backflow.
- Improved durability by reducing chattering caused by water turbulence (903L).
- Light weight, compact, user friendly and easy care
- Bypass valve standardly installed enables to simplify piping work and save space (903L, 905C 65mm to 400mm).

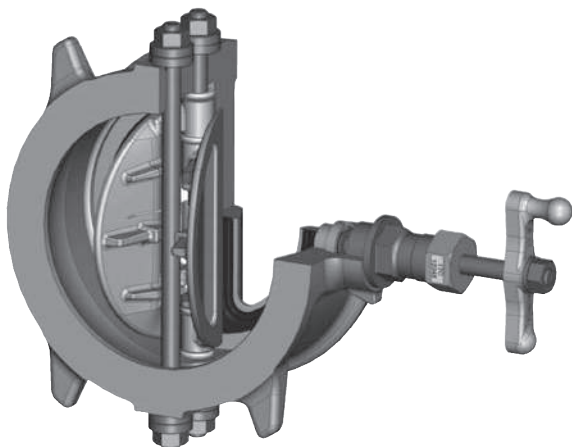

Comparison between swing check valve and Bata-Check 903L

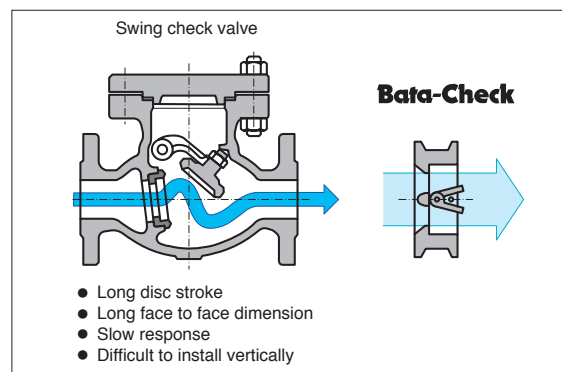

*1 These are common features of 903L, 901C, 905C and 906C unless otherwise specified.

*2 Above drawing is an example. Shape of each part differs depending on model and size.

Butterfly Valve
TRITEC
TT2
334A
344Q
302A/303Q
304A/304Q
304YA
302Y/304Y
304M (HLV)
507V/508V
DTM
846T/847T/847Q
841T/842T
700Z
700G/704G/705G
72WG/72SG/72LG
731P/732P/732Q/752W
731R
700E/700K/700S
704G/722F/720F
227P
907T/908H (MKT)
903L/901C/905C (Bata-check)

Standard Specifications

		903L	901C	905C
Valve nominal size		50mm to 300mm	350mm to 450mm	50mm to 400mm
Face-to-face dimensions		Manufacturer standard		API 594 Class300 125A: Manufacturer standard
Flange accommodation ^{※1}		JIS 5K, 10K	JIS 10K (Option: 5K ^{※1})	JIS 30K
Max. working pressure ^{※2}		1.0 MPa		3.0 MPa
Seat leakage (when checking)		Tight shut-off (JIS B 2003:2013 Rate A) Equivalent or more differential pressure shown below is required.		
Required differential pressure ^{※3}		0.02 MPa ^{※3}	0.02 MPa	0.05MPa
Average velocity inside pipe		4 m/s	3 m/s	
Chattering prevention		No 2D or longer straight pipe which is the same in nominal size is required before valve		No 3D or longer straight pipe which is the same in nominal size is required before valve.
Working temperature range	NBR	-10 ~ 80 °C	-10 ~ 80 °C	—
	EPDM	-20 ~ 100 °C	-20 ~ 120 °C	-5 ~ 100 °C
	FKM	0 ~ 100 °C	0 ~ 120 °C	—
Working temperature in continuous use ^{※4}	NBR	0 ~ 60 °C	0 ~ 60 °C	—
	EPDM	0 ~ 70 °C	0 ~ 100 °C	-5 ~ 100 °C
	FKM	5 ~ 80 °C	5 ~ 100 °C	—
Standard materials	Body	FC250		SCPH2
	Plate ^{※5}	SCS13	CAC702 ^{※5}	SCS13
	Seat ring ^{※6,7,8}	NBR (option: EPDM, FKM) (Vulcanized to valve body)		EPDM(standard) (Vulcanized to valve body)
	Shaft pins	SUS304		
	Spring	SUS304		SUS316
Test pressure	Body shell test	1.5 MPa (hydraulic)		4.5 MPa (hydraulic)
	Seat leakage	High pressure 1.1MPa(pneumatic) 0.02MPa(pneumatic)	1.1MPa(hydraulic) 0.02MPa(hydraulic)	0.6 MPa (pneumatic)
Accessories ^{※5}	Bypass valve (standard)		No bypass valve	Bypass valve(standard) (Except for 50mm)
	High torque spring Low torque specification ^{※10 ※11}		High torque spring Low torque spring ^{※11}	
Pipe gasket		Required		
Fluid types ^{※5,7,8,9}		Water, air		
Coating		Urethane coating (Tomoe green)	Etching primer (Dark green)	Phthalic acid resin coating (Munsell 5PB 3/9 Dark blue)

※1 901C JIS5K is special specifications. Please consult us.

※2 Bata-check cannot be used under negative pressure. Do not install underwater or underground.

※3 Required differential pressure of 903L differs depending on installing condition and spring selection. Please refer to spring selection table.

※4 "Working temperature in continuous use" stands for the temperature continuously kept for over one hour. Provided that fluid is not frozen inside.

※5 As parts of plate and bypass are made of copper alloy, a fluid which corrodes copper alloy such as acetylene and ammonia can not be used.

※6 EPDM seat ring is recommended in case of using chemical containing calcium for maintenance.

※7 EPDM seat ring can not be used for oil or a fluid containing oil. A fluid containing chlorine can accelerate damage to rubber seat ring, depending on density and temperature of fluid. Please consult us for detail.

※8 A fluid containing alkali and acid can weaken bond of seat ring. Please consult us for detail.

※9 Bata-check can not be used for viscous fluid or a fluid containing powder. In case of gas, please refer to spring selection table for installing condition.

※10 Spring is not supplied with 903L low torque specification.

※11 Standard spring will be supplied unless otherwise specified.

Select valve according to fluid and installing condition. Incorrect valve selection can cause vibration and abnormal noise.
Please refer to spring selection table and manual before use.

Bata-Check Series Dual plate wafer check valve

Bata-Check Selection Criteria

903L

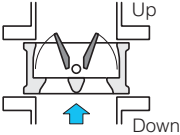
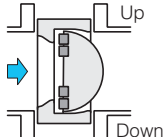
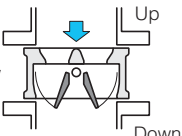
Flow Direction	Fluid	Condition	Min. differential pressure (MPa)	Size (mm)	Spring
Up flow 	Liquid	Installed directly after the same size, 2D or longer straight pipe	0.01	50~300	High torque
			0.02		Standard
	Gas	Forward direction, primary pressure 0.1MPa or more	0.04		Low torque specification (no spring)
Horizontal layout 	Liquid	Installed directly after the same size, 2D or longer straight pipe	0.02	50~300	High torque
			0.04	50~200	Standard
	Gas	Forward direction, primary pressure 0.15MPa or more	0.04	50~200	Standard
Down flow 	Liquid	Installed directly after the same size, 2D or longer straight pipe	0.06	50~150	High torque

※ Equivalent or more pressure shown in the table is needed for sealing performance. When inlet pressure remains, differential pressure may not be maintained. Especially in case of down flow, inlet pressure easily remains.

※ In case of liquid, inlet pressure of forward direction needs to be higher than cracking pressure and lower than max. working pressure.

901C

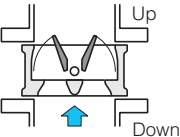
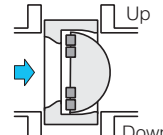
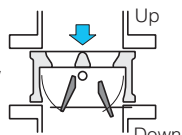
Flow Direction	Fluid	Condition	Min. differential pressure (MPa)		Size (mm)	Spring
			Min	Max		
Up flow 	Liquid	Installed directly after the same size, 2D or longer straight pipe	0.7	~ 1.0	350~450	High torque
			0.1	~ 0.7		Standard
			0.05	~ 0.1		Low torque
	Gas		0.05	~ 0.1		Low torque
Horizontal layout 	Liquid	Installed directly after the same size, 2D or longer straight pipe	0.7	~ 1.0	350~450	High torque
			0.1	~ 0.7		Standard
			0.05	~ 0.1		Low torque
	Gas		0.05	~ 0.1		Low torque
Down flow 	Liquid Gas	Installed directly after the same size, 2D or longer straight pipe	0	~ 1.0	350~450	High torque

※ When inlet pressure remains, there is possibility of leakage. 0.02 MPa or more is needed to seal. Especially in case of down flow, inlet pressure easily remains.

※ When check valve is installed at the outlet of the pump, spring needs to be high torque spring regardless of pressure.

● 905C is supplied with standard spring only. It can not be used for dawn flow.

● 905C requires 3D or longer straight pipe upstream.

901C / 905C Expanded view of components

901C,905C Parts list

No.	Description	Q'ty	Remarks
1	Body	1	
2	Plate	2	
3	Spring	2	901C 905C (upper 150mm)
		1	905C (under 125mm)
4	Shaft pin	1	
5	Stop pin	1	
6	Seat	1	Vulcanized to body
7	Plug	4	
8a	Bearing	2	
8b	Bearing	3	905C (upper 150mm)
		2	905C (under 125mm)
9	Bearing	2	
10	Eye bolt	1	901C 905C (150mm to 300mm)
		2	905C (upper 350mm)
19	Name tag	1	
20	Bypass unit	1 set	905C (Except for 50mm)
26	Buffer	4	901C
27	Sleeve	1	905C (under 150mm)
		2	905C (150mm to 300mm)

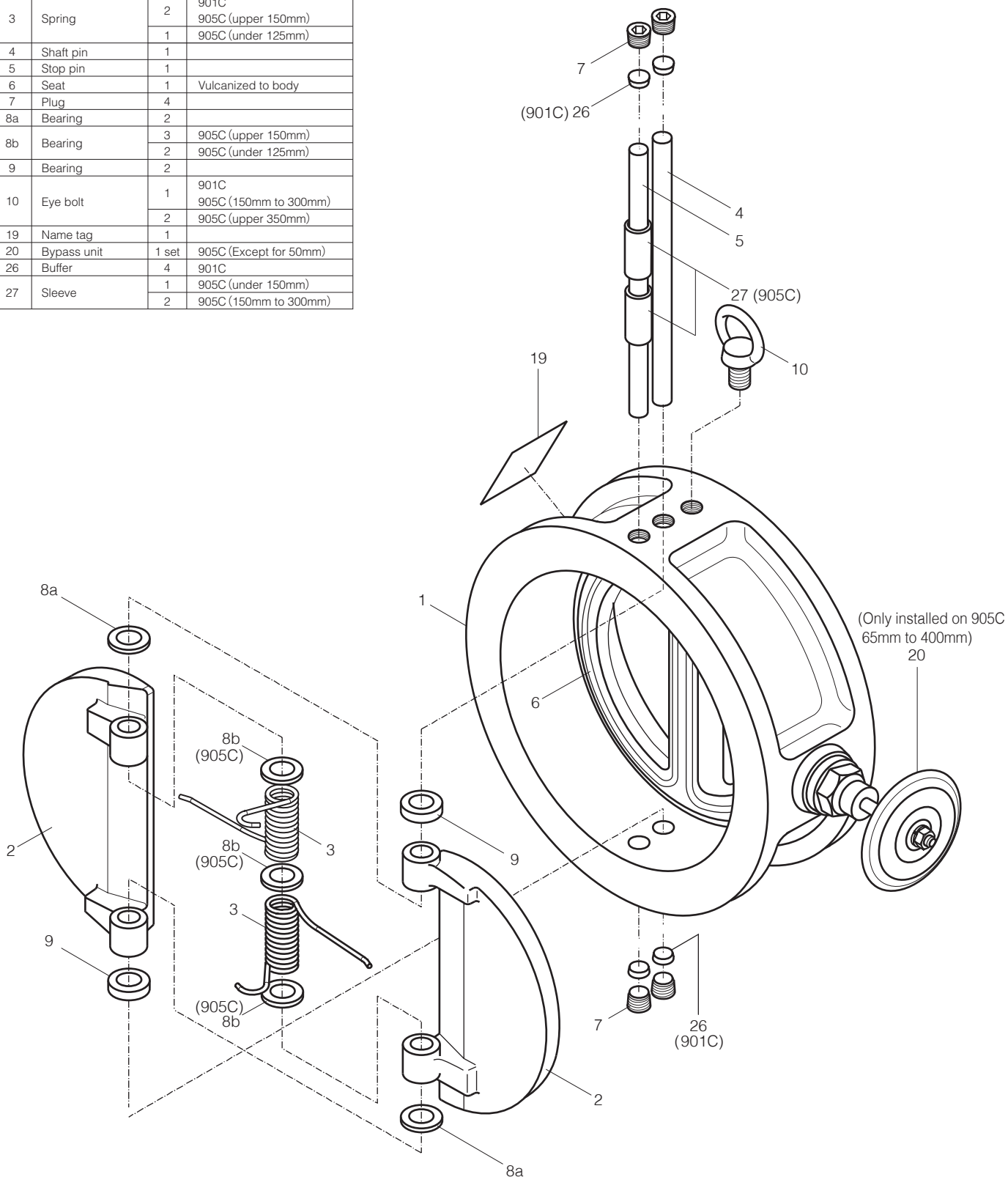

Bata-Check Dimension

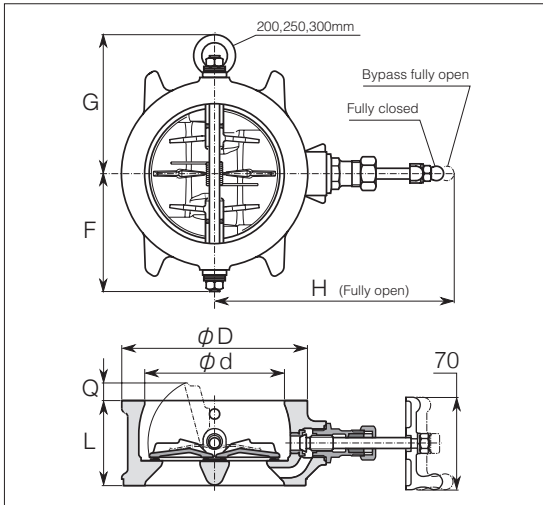

903L

Nominal size		Dimension(mm)								Approx. Mass (kg)
mm	inch	ϕd	L	ϕD	H	F	G	Q		
50	2	61	56	90	159	59	—	0	1.8	
65	2 1/2	74	56	114	167	72	—	6	2.5	
80	3	87	60	130	173	84	—	9	3.2	
100	4	109	66	145	186	92	—	16	4.0	
125	5	140	70	180	200	110	—	27	5.8	
150	6	163	76	210	214	125	—	36	8.3	
200	8	214	95	265	240	160	169	45	15	
250	10	268	108	320	295	187	197	60	24	
300	12	316	144	373	320	221	232	58	39	

※ The drawing on the left is representative example. For detail, please refer to specifications.

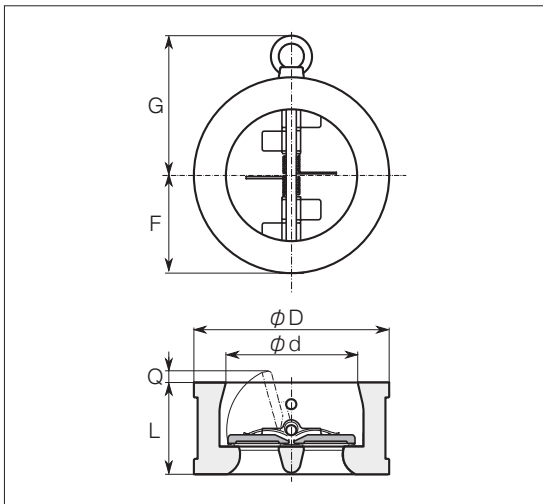

901C

Nominal size		Dimension(mm)								Approx. Mass (kg)
mm	inch	ϕd	L	ϕD	H	F	G	Q		
350	14	356	184	420	—	212	252	60	60	
400	16	406	190	483	—	244	293	89	76	
450	18	458	200	538	—	271	320	112	93	

※ The drawing on the left is representative example. For detail, please refer to specifications.

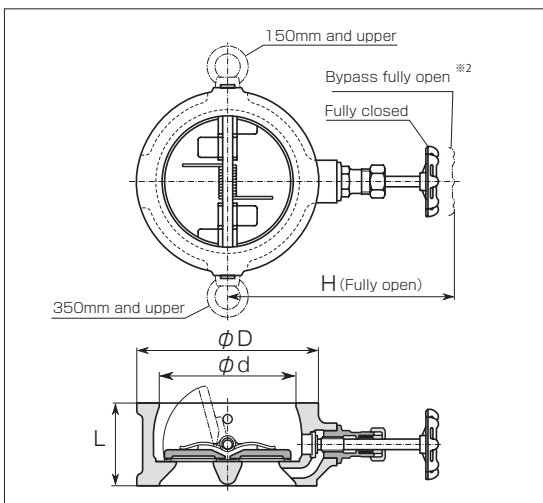

905C

Nominal size		Dimension(mm)					Approx. Mass (kg)
mm	inch	ϕd	L	ϕD	H ^{※1}		
50	2	60	60	111	※2	5.0	
65	2 1/2	73	67	137	180	6.0	
80	3	89	73	147	200	7.0	
100	4	114	73	170	200	9.5	
125	5	141	86	205	230	16	
150	6	168	98	248	250	30	
200	8	219	127	293	280	46	
250	10	273	146	357	300	70	
300	12	324	181	417	330	130	
350	14	356	222	462	350	185	
400	16	406	232	521	380	200	

※1 H includes space to operate.

※2 Bypass valve is not installed on 905C 50A.

※ The drawing on the left is representative example For detail, please refer to specifications.

Butterfly Valve

TRITEC

TT2

334A

344Q

302A/303Q

304A/304Q

304YA

302Y/304Y

304M

(HLV)

507V/508V

DTM

846T/847T/847Q

841T/842T

700Z

700G/704G/705G

72WG/72SG/72LG

731P/732P/732Q/752W

731R

700E/700K/700S

704G/722F/720F

227P

907T/908H

(MKT)

903L/901C/905C

(Bata-check)

Bata-Check Pressure loss vs. Flow rate

■ 903L (50 to 300mm) / 901C (350 to 450mm)

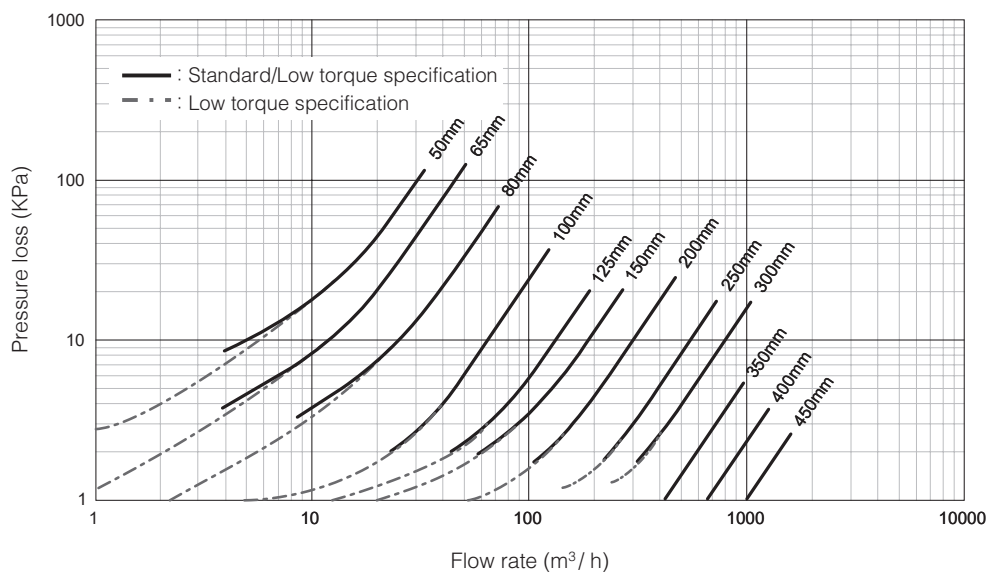

Nominal size (mm)	Cv value (—)	Resistance coefficient ζ (—)
50	35	14
65	52	15
80	101	7.8
100	235	4.3
125	485	2.4
150	684	2.4
200	1100	2.9
250	2030	2.0
300	2930	2.0
350	4780	1.1
400	7500	0.81
450	11400	0.56

※ For high torque spring and 905C, please consult our sales staff.

Bata-Check Cracking pressure (opening pressure) & Diameter of piping

903L Cracking pressure

Flow direction Spring Nominal size	Horizontal		Vertical(up flow)		
	Standard spring	High torque spring	Low torque spring	Standard spring	High torque spring
mm	KPa	KPa	KPa	KPa	KPa
50	5.7	5.7	0.61	6.8	6.8
65	2.8	5.1	0.66	3.8	6.1
80	2.7	3.2	0.62	3.3	3.9
100	1.3	2.9	0.69	2.1	3.7
125	1.4	2.9	0.76	2.0	3.7
150	1.1	2.9	0.82	2.0	3.7
200	0.70	2.8	0.94	1.8	3.7
250	—	2.1	1.2	1.8	3.2
300	—	2.0	1.3	1.8	3.2

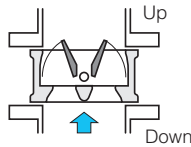
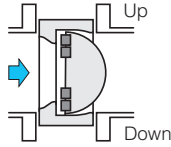

901C Cracking pressure

Flow direction Spring size	Horizontal	Vertical (Upwards direction)	
	Standard spring	Low torque spring	Standard spring
mm	KPa	KPa	KPa
350	0.41	2.6	2.9
400	0.39	2.7	3.0
450	0.33	2.7	2.9

※ For 905C, please consult sales staff.

- Cracking pressure (opening pressure) is minimum pressure that allows a fluid to flow stably in a forward direction. Flow would not be stable even a fluid flows under this pressure.
- Internal diameter of piping shall be equal to Pi or over. In case of lined pipe, take lining into accounts when you check internal diameter. JIS G3452 SGP, JIS G3454 Sch60 and under, JIS G3459 Sch40 and under and VP pipe are applicable. In addition, JIS G3454, JIS G3459 "Sch80" are also applicable in case of 905C.
- Internal diameter of gaskets contact part needs to be smaller than maximum internal diameter (Fi). JIS B2220 SOP, SOH, WN, IT, SW and TS (resin pipe) are applicable.
- In case of loose flange, internal diameter of flat collar (except for the rounded part) needs to be smaller than maximum internal diameter (Fi). JIS B2309 and SAS 363(type 2) are applicable.

903L Internal diameter of piping

Nominal size	Minimum internal diameter of piping	Maximum internal diameter
	Pi	Fi
mm	mm	mm
50	41	63
65	55	86
80	67	98
100	91	117
125	121	144
150	145	171
200	190	227
250	239	274
300	286	332

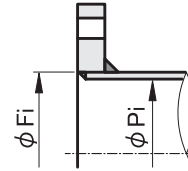

901C Internal diameter of piping

size	Minimum internal diameter	Maximum internal diameter
	Pi	Fi
mm	mm	mm
350	270	367
400	340	413
450	405	470

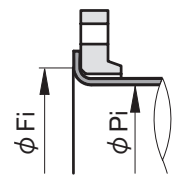

Loose flange

Butterfly Valve

TRITEC

TT2

334A

344Q

302A/303Q

304A/304Q

304YA

302Y/304Y

304M

(HLV)

507V/508V

DTM

846T/847T/847Q

841T/842T

700Z

700G/704G/705G

72WG/72SG/72LG

731P/732P/

732Q/752W

731R

700E/700K/700S

704G/722F/720F

227P

907T/908H

(MKT)

903L/901C/

905C(Bata-check)

Bata-Check Applicable pipe list in case of A

Type	Nominal size		SGP	STPY	Sch20	Sch40	Sch10S	Sch20S
	mm	inch						
903L	50	2	○	—	○	○	○	○
	65	2 1/2	○	—	○	○	○	○
	80	3	○	—	○	○	○	○
	100	4	○	—	○	○	○	○
	125	5	○	—	○	○	○	○
	150	6	○	—	○	○	○	○
	200	8	○	—	○	○	○	○
	250	10	○	—	○	○	○	○
	300	12	○	—	○	○	○	○
901C	350	14	○	○	○	○	—	—
	400	16	○	○	○	○	—	—
	450	18	○	○	○	○	—	—

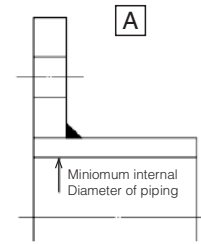

Remark : ○ : Installation possible, — : No standard

※ For 905C, please consult sales staff.

Bata-Check Applicable pipe list in case of B

Type	Nominal size		SGP	STPY	Sch20	Sch40	Sch10S	Sch20S
	mm	inch						
903L	50	2	○	—	○	○	○	○
	65	2 1/2	○	—	○	○	○	○
	80	3	○	—	○	○	○	○
	100	4	○	—	○	○	○	○
	125	5	○	—	○	○	○	○
	150	6	○	—	○	○	○	○
	200	8	○	—	○	○	○	○
	250	10	○	—	○	○	○	○
	300	12	○	—	○	○	○	○
901C	350	14	○	○	○	○	—	—
	400	16	○	○	○	○	—	—
	450	18	○	○	○	○	—	—

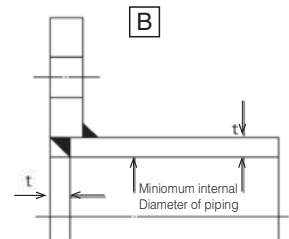

Remark : ○ : Installation possible, — : No standard

※ For 905C, please consult sales staff.

Bata-Check Piping bolt and nut sizes

Type		903L		901C	905C
Nominal size		JIS 5K	JIS 10K	JIS 10K	JIS 30K
mm	inch	Hexagon bolts and nuts		Long Bolts and nuts	Long Bolts and nuts
50	2	4-M12X110X40	4-M16X120X40	—	8-M16X155X40
65	2 1/2	4-M12X110X40	4-M16X120X40	—	8-M20X180X40
80	3	4-M16X115X40	8-M16X120X40	—	8-M20X190X50
100	4	8-M16X125X40	8-M16X130X40	—	8-M22X200X50
125	5	8-M16X130X50	8-M20X140X50	—	8-M22X220X50
150	6	8-M16X140X50	8-M20X150X50	—	12-M24X250X50
200	8	8-M20X170X50	12-M20X170X50	—	12-M24X280X60
250	10	12-M20X190X50	12-M22X190X50	—	12-M30X320X60 ^{※1}
300	12	12-M20X220X50	16-M22X230X50	—	16-M30X365X60 ^{※1}
350	14	—	—	16-M22X300X45	16-M30X540X80 ^{※1}
400	16	—	—	16-M24X320X50	16-M36X590X80 ^{※1}
450	18	—	—	20-M24X320X50	—

- ※1 Bolt pitch for M30 and over is 3.
- ※ Material: SS400 unichrome plating
- ※ Length of bolt is calculated based on thickness of JIS B 2220:²⁰¹² steel pipe flange (except for 10K thin type), size of JIS B 1181:²⁰¹⁴ style 1 hexagon nut and 3mm thickness of gaskets.
- ※ Do not use rusted, damaged or deformed bolt or nut. Lubricate screws enough.
- ※ Number of bolt shown above is needed for one piece of valve.

Example

Long bolts : 12 - M22 × 185 × 45
 Quantity Nominal size(M) Length of bolt(L) Effective screw length(S)

Setting bolts (Hexagon bolts) : 4 - M30 × 95 × 65
 Quantity Nominal size(M) Length of bolt(L) Effective screw length(S)

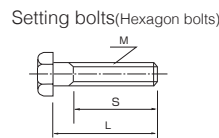
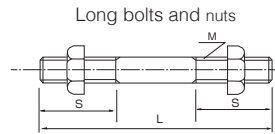

Bata-Check Gasket

Commercially available gaskets which are appropriate for flange standard and fluid condition can be used. Our recommendation is as follows:

- Size : JIS B 2404 (size of flange used)
- Type : Seat gaskets (Non-metal flat gasket)
- Shape : Ring gaskets
- Material : JIS R 3453 joint sheet / Reinforced rubber / RPTFE
- Thickness : 1.5 to 3mm (3mm is recommended.)
- Quantity : 2 pieces/valve

- ※ In case of resin flange, use gaskets which is recommended by flange manufacturer.
- ※ Perform centering appropriately so that a gasket at outlet side does not distract plates. Gaskets tend to protrude inner side due to pressure; especially they are made of rubber.

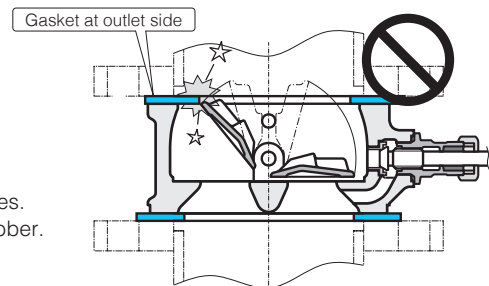

Misalignment of gaskets causes malfunction.

Butterfly Valve
TRITEC
TT2
334A
344Q
302A/303Q
304A/304Q
304YA
302Y/304Y
304M (HLV)
507V/508V
DTM
846T/847T/847Q
841T/842T
700Z
700G/704G/705G
72WG/72SG/72LG
731P/732P/732Q/752W
731R
700E/700K/700S
704G/722F/720F
227P
907T/908H (MKT)
903L/901C/905C (Bata-check)