

731P Wafer

732P Wafer

732Q Lugged

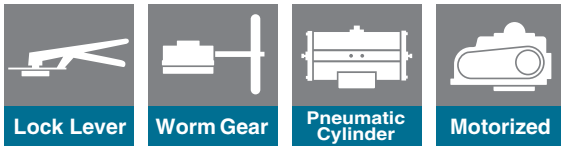
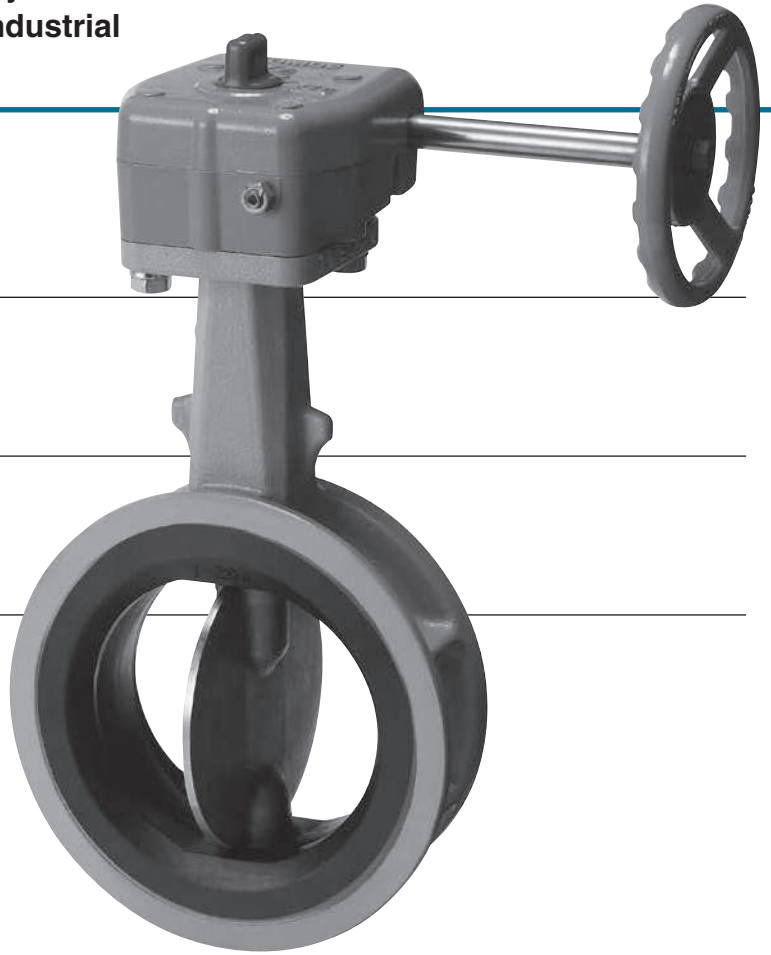

Lock Lever

Worm Gear

Pneumatic Cylinder

Motorized

Features and Benefits

Vulcanized rubber lining on the body

The seat is vulcanized to the body which ensures correct rubber compression and greater strength of the rubber seat. This design is much more effective in high velocity and industrial vacuum applications than soft resilient seated valves.

New cosine-curve seat

The new cosine-curve seat (patent pending) allows better performance in reducing friction, torque and wear than the previous design.

Cubical shape by lowering height

The height of the raised part of the seat in the narrow area is lower. It provides strength and sealing performance by preventing the movement of the raised portion of the seat in high pressure applications.

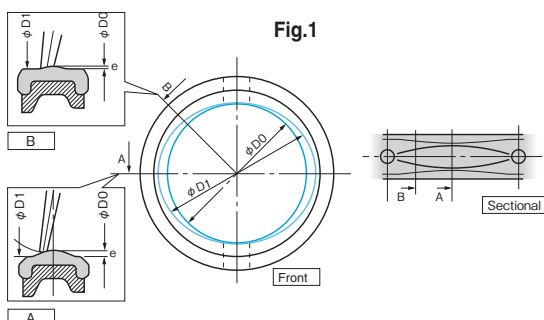

Tapered finish

To make the flow characteristic at small valve opening as close to linear as possible, the edge of the seat is tapered. This makes for a smoother flow and better performance in high velocity working conditions. The taper is narrow around the stem area and wide around the wing of the disc area to provide strength and sealing performance for the rubber seat.

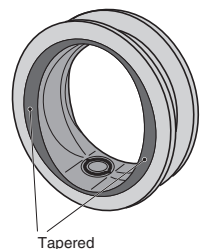

New streamlined shape around stem hole

Although the spherical disc provides good sealing performance and extended life for our rubber lined valves, it still produces relatively high forces around the stem hole area where a large contact surface exists. In order to produce greater pressure at this point of contact with less friction, we incorporate a labyrinth effect where six small raised lines are moulded around the stem hole.

Features a concentric design with tight 100% bi-directional shut-off, low torque and a maximum working pressure of 1.6MPa to 2.0MPa.

Tapered Finish

Fig. 2

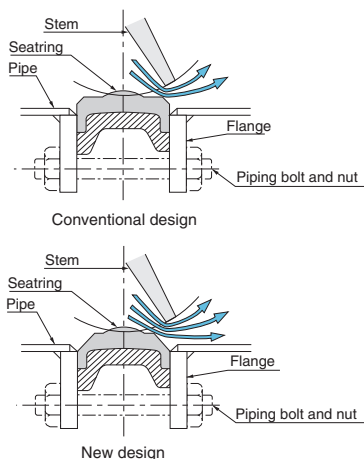

New streamline shape around stem hole

Fig. 3

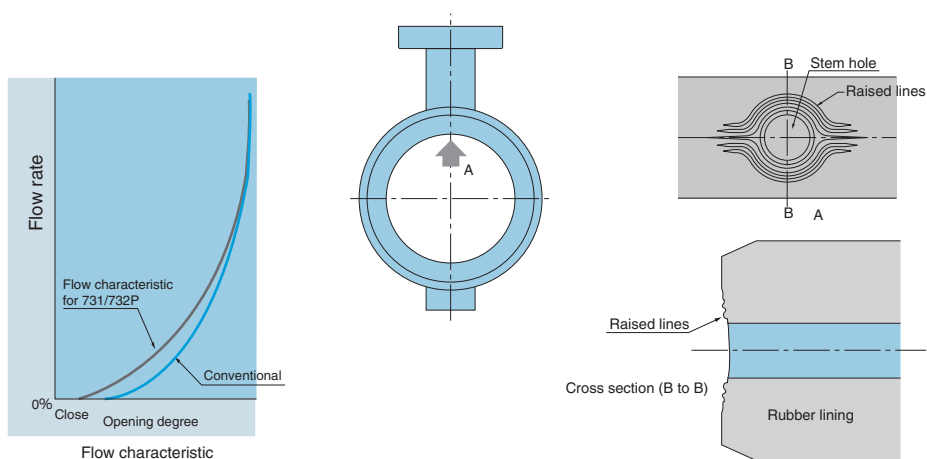

Standard Specifications

Type	1.6MPa (16K) type	2.0MPa (20K) type	1.6MPa (16K) type	2.0MPa (20K) type
	731P (Wafer)	732P (Wafer)	732X (Wafer), 732Q (Lugged)	
Valve nominal size	50mm to 300mm			
Flange accommodation	JIS 10K/16K/20K, ASME Class125/150, DIN PN 10/16/25, BS 4504 PN 10/16/25			
Face-to-face dimensions	JIS B 2002 (2032) 46 series / ISO 5752 (20 series)			
Max. working pressure	1.6MPa	2.0MPa	1.6MPa	2.0MPa
Seat leakage	Tight-shutoff			
Flow direction	Bi-direction			
Body shell test	JIS16K/20K, ASME Class150, DIN NP16, BS 4504 PN16: 2.4MPa Others: 1.5MPa (hydraulic)	3.0MPa (hydraulic)	JIS16K/20K, ASME Class150, DIN NP16, BS 4504 PN16: 2.4MPa Others: 1.5MPa (hydraulic)	3.0MPa (hydraulic)
Seat leak test	JIS16K/20K, ASME Class150, DIN NP16, BS 4504 PN16: 1.76MPa Others: 1.1MPa (pneumatic)	2.2MPa (pneumatic)	JIS16K/20K, ASME Class150, DIN NP16, BS 4504 PN16: 1.76MPa Others: 1.1MPa (pneumatic)	2.2MPa (pneumatic)
Velocity range	Max. 6Max. 6m/sec (when fully open)			
Working temperature range	NBR : -10 to 80 degrees C, EPDM : -20 to 120 degrees C			
Working temperature in continuous use ※1	NBR : 0 to 60 degrees C, EPDM : 0 to 70 degrees C			
Standard materials	Body	FCD450	FCD450, SCPH2	
	Disc	SCS14	SCS14/CAC702, CAC703	
	Stem	420J2 S.S	420J2 S.S, MONEL K-500	630 S.S, MONEL K-500
	Seat ring ※2	NBR, *EPDM		
Top flange	ISO 5211			
Condensation prevention structure	Optional (Condensation prevention resin column)			
Piping flange gasket	Not required			
Coating	Epoxy primer (Munsell N7)		Lacquer primer (Munsell N7)	

Note) If the following specifications are required, please consult our sales office.

- (1) High durability required because the number of opening/closing times exceeds 100,000.
- (2) Continuous operation required with a valve opening angle of 30 degrees or less.
- (3) Control operation which requires 3% or lower hysteresis accuracy of the valve itself.
- ※1 'Working temperature in continuous use' stands for the temperature continuously kept exceeding one hour.
- ※2 Never use an EPDM rubber seat ring if the valve is being used for oil or for a fluid containing even a slight amount of oil.
- * Disc with pin finish is also available upon request for 732P.

Butterfly Valve
TRITEC
TT2
334A
344Q
302A/303Q
304A/304Q
304YA
302Y/304Y
304M (HLV)
507V/508V
DTM
846T/847T/847Q
841T/842T
700Z
700G/704G/705G
72WG/72SG/72LG
731P/732P/732Q/752W
731R
700E/700K/700S
704G/722F/720F
227P
907T/908H (MKT)
903L/901C/905C (Bata-check)

Ideal, Cost Effective Valve for Use in High Velocity, High Pressure and Industrial Vacuum Applications

731P Wafer

732P Wafer

732Q Lugged

752W Lugged

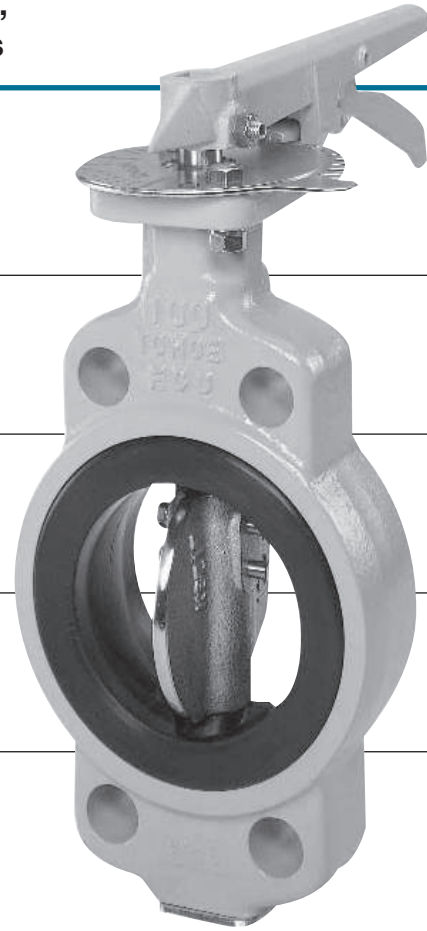

Features and Benefits

Perfect sealing against high pressure to 2.0MPa

By employing a cosine-curve design seat ring, the disc contacts simultaneously around the entire seat during closure which enables perfect sealing against pressures up to 1.96MPa. Perfect sealing is assured in high differential pressure, high velocity and vacuum applications. The operation torque for the valve is substantially reduced. Also, since the body is covered with the seat ring, it is never exposed to fluid.

No restrictions in direction of flow even for high differential pressures

With a concentric design and low operating torque, 731P/732P can perfectly seal pressures up to 2.0MPa or 1.6MPa for both directions.

Face-to-face dimensions satisfy ISO standards

The face-to-face dimensions satisfy BS 5155 and ISO 5752. It is also adaptable to many international flange standards.

Long neck

The long neck enables insulation of up to 50mm after installation of the valve.

O-ring case with self-aligning stem seal function

The stainless steel O-ring case (utility model) counteracts any stem displacement and shaft tilt caused during the operation of the valve under fluid pressure. Because this O-ring is never exposed to the fluid, it never erodes.

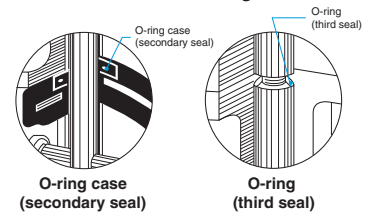

The rubber seat is reinforced with a metallic core

Since this reinforced seat ring is clamped in position by the flanges, it is much more effective in high velocity and industrial vacuum applications than a soft resilient seat without a metallic core. Moreover, the seat ring can easily be replaced (350 to 600mm types). The vulcanized seat to the body is used in sizes 50 to 80mm.



Stainless steel disc as a standard material

Stainless steel disc provides excellent corrosion resistance in various applications.

General Description

With applications for high pressure service valves increasing, TOMOE have developed a new 20K type in addition to the traditional 16K type. The 20K type is designed to seal high pressures up to 2.0MPa, while the 16K type can seal up to 1.6MPa. This concentric butterfly valve incorporates a cosine-curve design seat ring reinforced with a metallic core and provides excellent cost advantages.

14" to 24" (350 to 600mm)

Parts List (standard)

No.	Parts	Materials
1	Body	Ductile cast Iron
2	Disc	Stainless steel casting
3	Stem	Stainless steel
4	Bush	METALOPLAST
5		
6	Mild steel / ductile cast iron	Bottom cover
8	Taper bolt	Stainless steel
10	Bolt & SP. washer	Mild steel / high carbon steel
12	Seat ring	Elastomer
13	O-ring	Elastomer
14	Packing	Asbestos
15	O-ring	Elastomer
16	Ball	Steel
17	Bolt	Carbon steel
18	Lock nut	Mild steel
22	Core	Mild steel

Standard Specifications

Type	1.6MPa (16K) type			2.0MPa (20K) type		
	731P (Wafer)	732Q (Lugged)	752W (Lugged)	732P (Wafer)	732Q (Wafer)	752W (Lugged)
Valve nominal size	350mm to 600mm	350mm to 400mm	450mm to 600mm	350mm to 600mm	350mm to 400mm	450mm to 600mm
Flange accommodation	JIS 10K/16K/20K, ASME Class125/150, DIN PN 10/16, BS 4504 PN 10/16					
Face-to-face dimensions	JIS B 2002 (2032) 46 series / ISO 5752 (20 series)					
Max. working pressure	1.6MPa			2.0MPa		
Seat leakage	Tight-shutoff					
Flow direction	Bi-direction					
Body shell test	JIS16K/20K, ASME Class150, DIN PN16, BS 4504 PN16: 2.4MPa Others: 1.5MPa (hydraulic)			3.0MPa (hydraulic)		
Seat leak test	JIS16K/20K, ASME Class150, DIN PN16, BS 4504 PN16: 1.76MPa Others: 1.2MPa (hydraulic)			2.2MPa (hydraulic)		
Velocity range	Max. 6m/sec (when fully open)					
Working temperature range	NBR : -10 to 80 degrees C, EPDM : -20 to 120 degrees C					
Working temperature in continuous use ※1	NBR : 0 to 60 degrees C, EPDM : 0 to 70 degrees C					
Standard materials	Body	FCD450 (SCPH2 as an option)	FCD450, SCPH2	FCD450 (SCPH2 as an option)	FCD450, SCPH2	
	Disc	SCS13 (SCS14 as an option)	SCS13 (SCS14 as an option), CAC702, CAC703	SCS13 (SCS14 as an option)	SCS13 (SCS14 as an option), CAC702, CAC703	
	Stem	420J2 S.S	420J2 S.S, MONEL K-500	630 S.S	420J2 S.S, MONEL K-500	
	Seat ring ※2	NBR, EPDM				
Top flange	ISO 5211					
Condensation prevention structure	Optional (Condensation prevention resin column)					
Piping flange gasket	Not required					
Coating	Lacquer primer (Munsell N7)					

Note) If the following specifications are required, please consult our sales office.

(1) High durability required because the number of opening/closing times exceeds 100,000.

(2) Continuous operation required with a valve opening angle of 30 degrees or less.

(3) Control operation which requires 3% or lower hysteresis accuracy of the valve itself.

※1 'Working temperature in continuous use' stands for the temperature continuously kept exceeding one hour.

※2 Never use an EPDM rubber seat ring if the valve is being used for oil or for a fluid containing even a slight amount of oil.

Butterfly Valve
TRITEC
TT2
334A
344Q
302A/303Q
304A/304Q
304YA
302Y/304Y
304M (HLV)
507V/508V
DTM
846T/847T/847Q
841T/842T
700Z
700G/704G/705G
72WG/72SG/72LG
731P/732P/732Q/752W
731R
700E/700K/700S
704G/722F/720F
227P
907T/908H (MKT)
903L/901C/905C (Beta-check)

731P/732P Expanded view of components

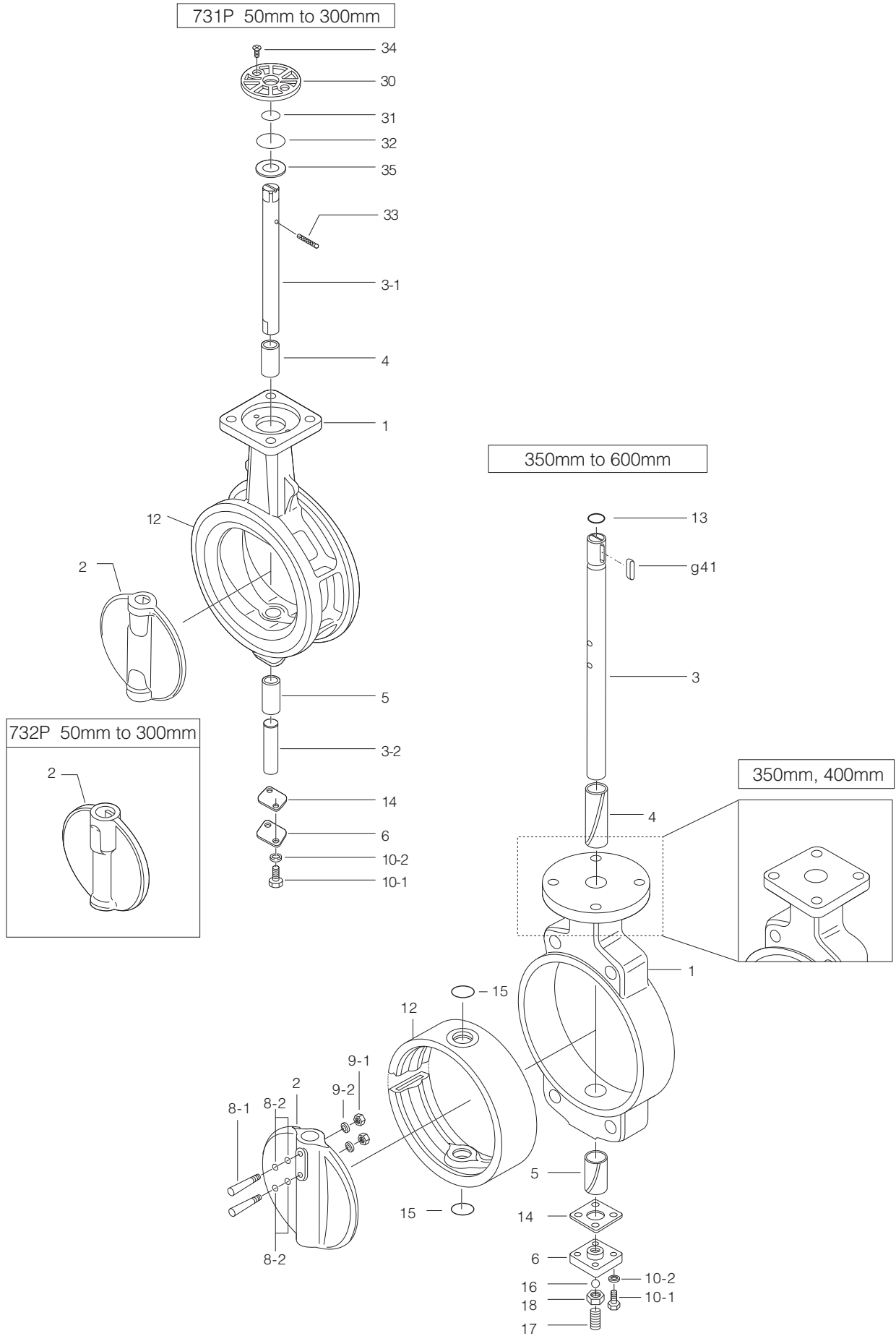

731P/732P Parts list

■ 731P/732P Parts list (50mm to 300mm)

No.	Description	Q'ty	Remarks
★ 1	Body	1	
2	Disc	1	
3-1	Upper stem	1	
3-2	Lower stem	1	
★ 4	Bearing	1	
★ 5	Bearing	1	
6	Bottom cover	1	
10-1	Hexagon bolt	2	
10-2	Spring washer	2	
★ 12	Seat ring	1	Vulcanized to body
★ 14	Gasket	1	
★ 30	Bushing	1	
★ 31	O-ring	1	
★ 32	O-ring	1	
33	Spring pin	1	
34	Machine screw	2	
35	Plate	1	

■ 731P/732P Parts list (350mm to 600mm)

No.	Description	Q'ty	Remarks
1	Body	1	
2	Disc	1	
3	Stem	1	
★ 4	Bushing	1	
★ 5	Bushing	1	
6	Bottom cover	1	
★ 8-1	Taper bolt	2	
★ 8-2	O-ring	4	
★ 9-1	Hexagon nut	2	
★ 9-2	Spring washer	2	
10-1	Hexagon bolt	4	
10-2	Stem key	4	
★ 12	Seat ring	1	
★ 13	O-ring	1	
14	Gasket	1	
★ 15	O-ring	2	
16	Ball	1	
17	Hollow bolt	1	
18	Lock nut	1	
g41	Key	1	

Remark: The ★ indicates recommended spare parts. They are supplied as "Seat ring set".

Butterfly Valve
TRITEC
TT2
334A
344Q
302A/303Q
304A/304Q
304YA
302Y/304Y
304M (HLV)
507V/508V
DTM
846T/847T/847Q
841T/842T
700Z
700G/704G/705G
72WG/72SG/72LG
731P/732P/732Q/752W
731R
700E/700K/700S
704G/722F/720F
227P
907T/908H (MKT)
903L/901C/905C (Bata-check)

731P/732P (Wafer) 732Q/752W (Lugged)

731P Actuator selection chart

731P

Model	Category	Size (mm / inch)														
		50	65	80	100	125	150	200	250	300	350	400	450	500	600	
		2	2 1/2	3	4	5	6	8	10	12	14	16	18	20	24	
1T	Standard Heavy duty	1T-1			1T-2			1T-3								
2I,2U 2S	Standard Heavy duty	2I-0	2I-1		2I-2		2I-3		2I-4		2U-5		MGH-3		MGH-4	
7E,3A	Standard Heavy duty	T35	T85		T200		T380		T750		TGA-125		TGA-140	TGA-160	TGA-200	
7G,7F 3U,3K	Standard Heavy duty	T85S	T200S		T380S		T750S		TG-12S		TG-14S		TG-20S			
4I	Standard Heavy duty	4I-00 4I-0	4I-1		4I-2		4I-2.5		4I-3		4I-4					
4J,4L	Standard Heavy duty	SRJ-010			SRJ-020			SRJ-060		LTKD-01 0.2kW /MGH-2		LTKD-01 0.4kW /MGH-3		LTKD-02 0.75kW /MGH-4		LTKD-05 0.75kW /MGH-5

Selection criteria	Standard	Select when none of the following heavy duty items apply.
	Heavy duty	Select when any of the following items apply. ① Powder or high viscosity fluid (crude oil, etc.) ② Control specification (with positioner) ③ Emergency open valve or pipe dead end valve ④ Air or Gas

731P Pressure-temperature rating

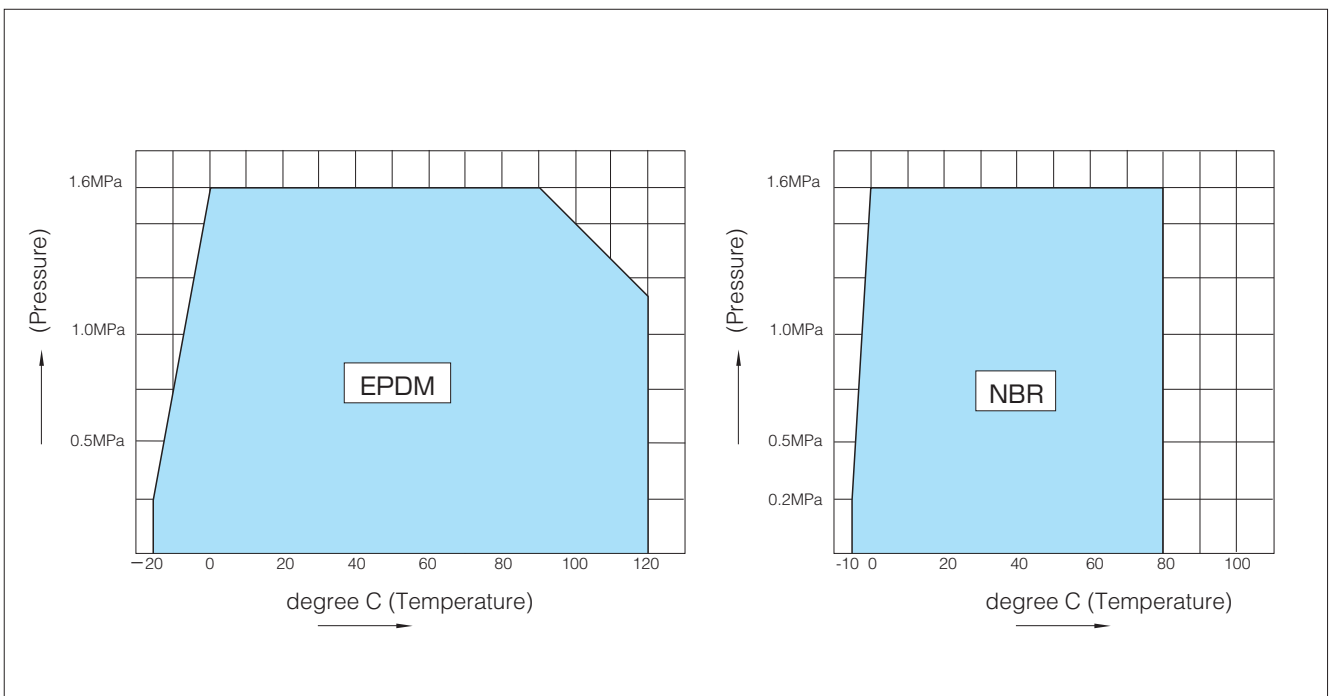

732P Actuator selection chart

732P

Model	Category	Size (mm / inch)															
		50	65	80	100	125	150	200	250	300	350	400	450	500	600		
		2	2 1/2	3	4	5	6	8	10	12	14	16	18	20	24		
1T	Standard	1T-1			1T-2			1T-3									
	Heavy duty	1T-1			1T-2			1T-3									
2I, 2U 2S	Standard	2I-0		2I-1		2I-2		2I-3		2I-4		2U-5		MGH-3		MGH-4	
	Heavy duty	2I-0		2I-1		2I-2		2I-3		2I-4		2U-5		MGH-3		MGH-4	
7E, 3A	Standard	T35		T85		T200		T380		T750		Please consult us regarding selection of drive parts for 350mm and higher.					
	Heavy duty	T35		T85		T200		T380		T750							
7G, 7F 3U, 3K	Standard	T85S		T200S		T380S		T750S		TG-10S						TG-12S	
	Heavy duty	T85S		T200S		T380S		T750S		TG-10S						TG-12S	
4I	Standard	4I-00 4I-0		4I-0		4I-1		4I-2		4I-3							
	Heavy duty	4I-00 4I-0		4I-0		4I-1		4I-2		4I-3							
4J, 4L	Standard	SRJ-010				SRJ-020				SRJ-060		LTKD-01 0.2kW /MGH-2					
	Heavy duty	SRJ-010				SRJ-020				SRJ-060		LTKD-01 0.2kW /MGH-2					

Selection criteria	Standard	Select when none of the following heavy duty items apply.
	Heavy duty	Select when any of the following items apply. ① Powder or high viscosity fluid (crude oil, etc.) ② Control specification (with positioner) ③ Emergency open valve or pipe dead end valve ④ Air or Gas

Butterfly Valve
TRITEC
TT2
334A
344Q
302A/303Q
304A/304Q
304YA
302Y/304Y
304M (HLV)
507V/508V
DTM
846T/847T/847Q
841T/842T
700Z
700G/704G/705G
72WG/72SG/72LG
731P/732P/732Q/752W
731R
700E/700K/700S
704G/722F/720F
227P
907T/908H (MKT)
903L/901C/905C (Bata-check)

732P Pressure-temperature rating

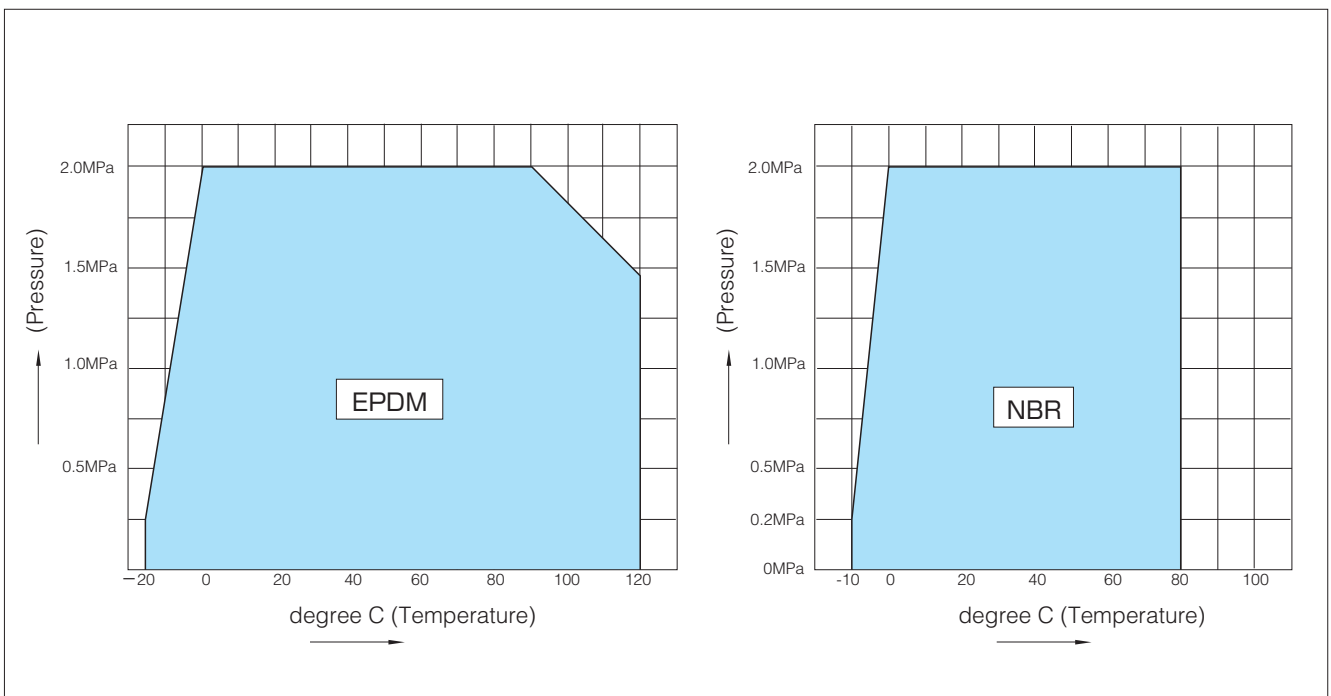

731P/732P (Wafer) 732Q/752W (Lugged)

Bare shaft 731P-01 (50mm to 300mm) / 731P-02 (350mm, 400mm)

731P-01 (50mm to 300mm) / 731P-02 (350mm, 400mm)

Type	Nominal size		Dimension (mm)													Approx. Mass (kg)	
	mm	inch	ϕd	ϕD		L	H ₁	H ₂	a ₁	a ₂	□S ₁	ϕd_2	b	t ₂	t		Flan ges
				JIS10K	JIS16K												
731P	50	2	54	102	102	43	68	138	21.5	10.5	8	10	—	—	11	F07	1.8
	65	2 1/2	67	122	122	46	79	151	21.5	10.5	8	10	—	—	11	F07	2.2
	80	3	82	132	138	46	86	156	22.5	11.5	10	12	—	—	11	F07	2.8
	100	4	103	157	163	52	103	167	22.5	11.5	12	14	—	—	11	F07	3.6
	125	5	129	188	200	56	118	191	27.5	16.5	14	16	—	—	13	F10	5.8
	150	6	152	218	235	56	135	202	27.5	16.5	14	18	—	—	13	F10	7.8
	200	8	198	267	280	60	177	227	29	20	18	22	—	—	13	F10	11.5
	250	10	251	330	353	68	216	280	34	30	24	28	—	—	14	F10	20.3
	300	12	300	375	403	78	254	312	35	30	24	32	—	—	16	F12	28.9
	350	14	336	415	415	78	304	340	54	48	—	40	12	3	20	F14	71
400	16	390	477	477	102	343	380	65	59	—	46	14	3.5	20	F14	107	

Flange dimensions

Flange	□S	ϕC_1	N	B.H.
F07	70	70	4	9
F10	102	102	4	11
F12	125	125	4	13
F14	140	140	4	19

Stem design
01: Square
02: Round with key

731P (16K) 50mm to 300mm

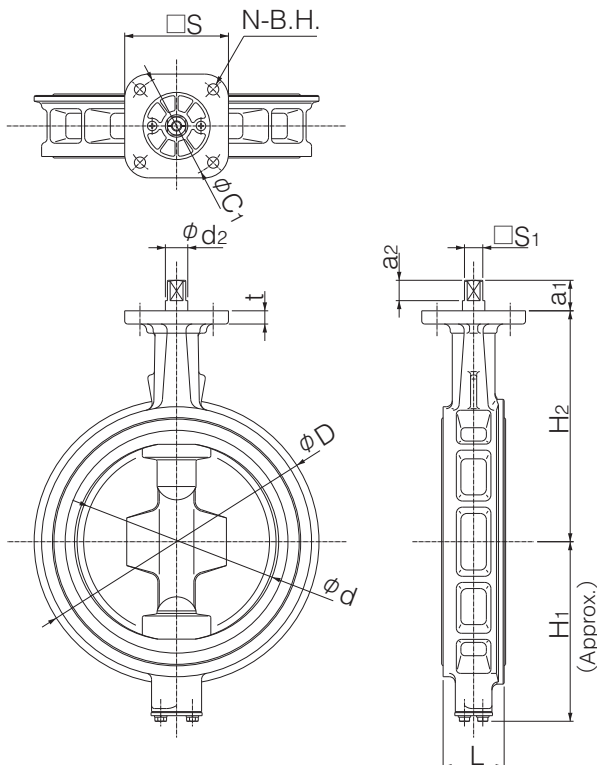

731P (16K) 350mm, 400mm

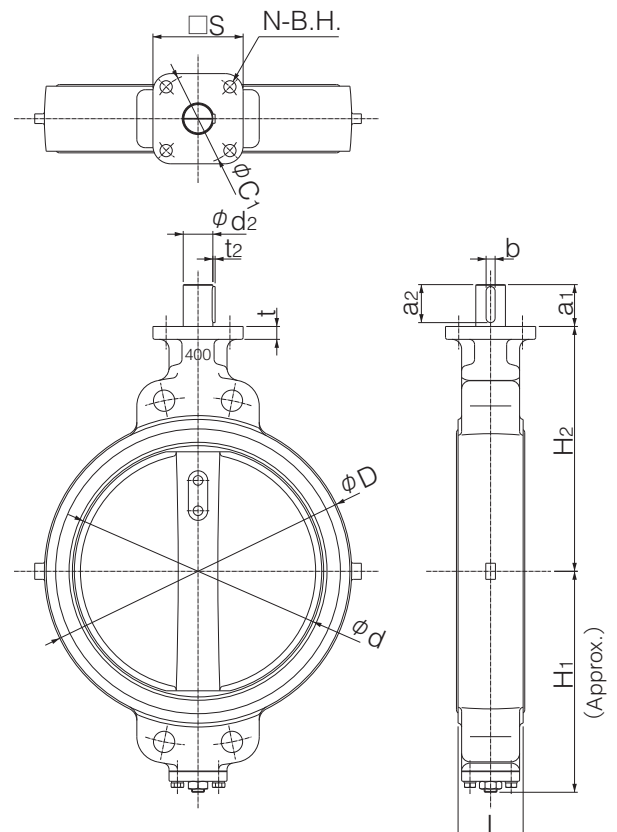

731P/732P (Wafer) 732Q/752W (Lugged)

Bare shaft 731P-02 (450mm to 600mm)

731P-02 (450mm to 600mm)

Type	Nominal size		Dimension (mm)															Approx. Mass (kg)	
	mm	inch	ϕd	ϕD		L	H ₁	H ₂	a ₁	a ₂	ϕd_2	b	t ₂	t	D ₁	C ₁	N		B.H.
				JIS10K	JIS16K														
731P	450	18	439	532	532	114	379	420	60	53	47	12	3.5	20	200	170	4	19	137
	500	20	490	610	610	127	422	450	60	53	47	12	3.5	20	200	170	4	19	188
	600	24	583	826	720	154	494	530	75	65	65	18	6	25	260	220	4	23	318(348)

Remark: Value in brackets is for JIS 10K flanges.

Flange dimensions

Flange	□S	ϕC_1	N	B.H.
F07	70	70	4	9
F10	102	102	4	11
F12	125	125	4	13
F14	140	140	4	19

731P (16K) 450mm to 600mm

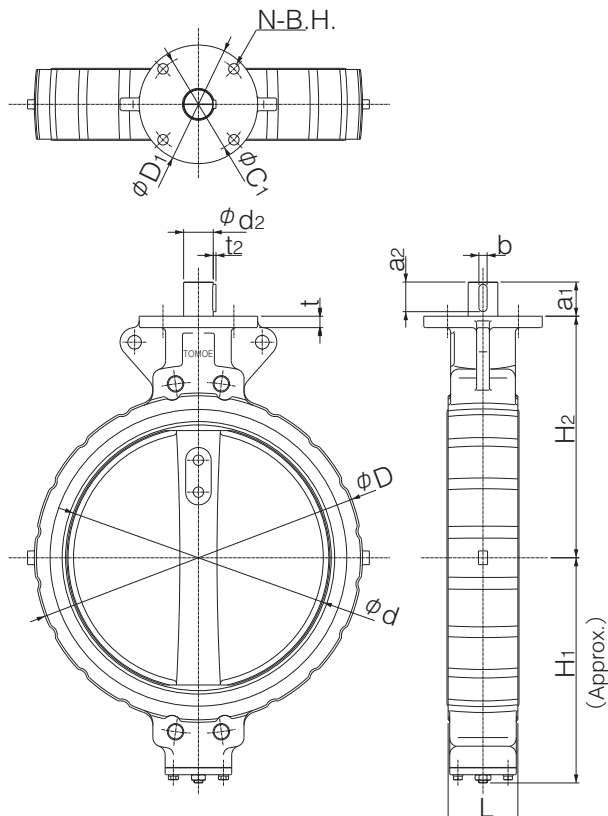

731P (10K) 600mm

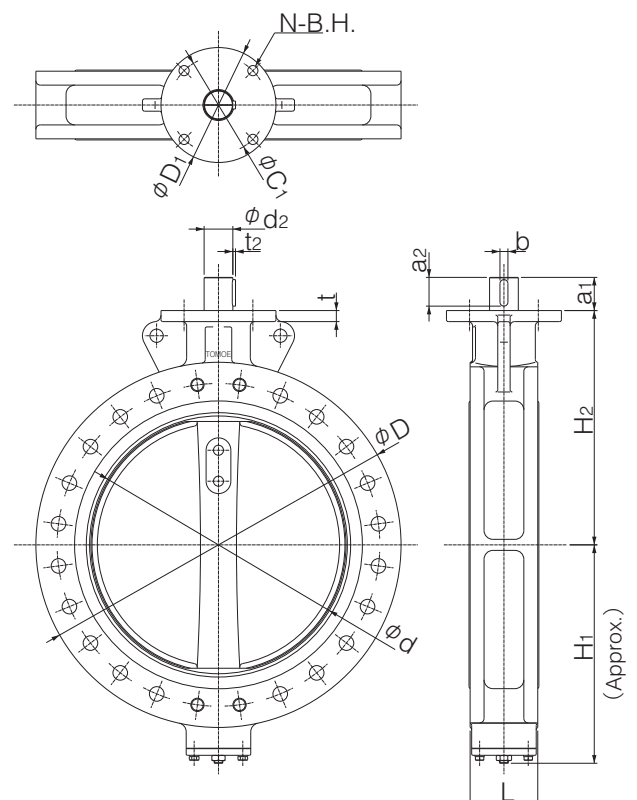

Bare shaft 732P-01 (50mm to 300mm) / 732P-02 (350mm, 400mm) / 732P-02 (450mm to 600mm)

■ 732P-01 (50mm to 300mm) / 732P-02 (350mm, 400mm)

Type	Nominal size		Dimension (mm)													Approx. Mass (kg)
	mm	inch	ϕd	ϕD	L	H ₁	H ₂	a ₁	a ₂	□S ₁	ϕd_2	b	t ₂	t	Flange	
732P	50	2	54	102	43	68	138	21.5	10.5	8	10	—	—	11	F07	1.9
	65	2 1/2	67	122	46	79	151	21.5	10.5	8	10	—	—	11	F07	2.3
	80	3	82	138	46	86	156	22.5	11.5	10	12	—	—	11	F07	3
	100	4	103	163	52	103	167	22.5	11.5	12	14	—	—	11	F07	3.8
	125	5	129	200	56	118	191	27.5	16.5	14	16	—	—	13	F10	6.1
	150	6	152	235	56	135	202	27.5	16.5	14	18	—	—	13	F10	7.7
	200	8	198	280	60	177	227	29	20	18	22	—	—	13	F10	12.1
	250	10	251	353	68	216	280	34	30	24	28	—	—	14	F10	21
	300	12	300	403	78	254	312	35	30	24	32	—	—	16	F12	29
	400	16	390	477	102	343	380	65	59	—	46	14	3.5	20	F14	107

■ Flange dimensions

Flange	□S	ϕC_1	N	B.H.
F07	70	70	4	9
F10	102	102	4	11
F12	125	125	4	13
F14	140	140	4	19

Stem design
 01: Square
 02: Round with key

■ 732P-02 (450mm to 600mm)

Type	Nominal size		Dimension (mm)														Approx. Mass (kg)	
	mm	inch	ϕd	ϕD	L	H ₁	H ₂	a ₁	a ₂	ϕd_2	b	t ₂	t	D ₁	C ₁	N		B.H.
732P	450	18	439	532	114	379	420	60	53	47	12	3.5	20	200	170	4	19	137
	500	20	490	610	127	422	450	60	53	47	12	3.5	20	200	170	4	19	188
	600	24	583	720	154	494	530	75	65	65	18	6	25	260	220	4	23	318

■ 732P (20K)
50mm to 300mm

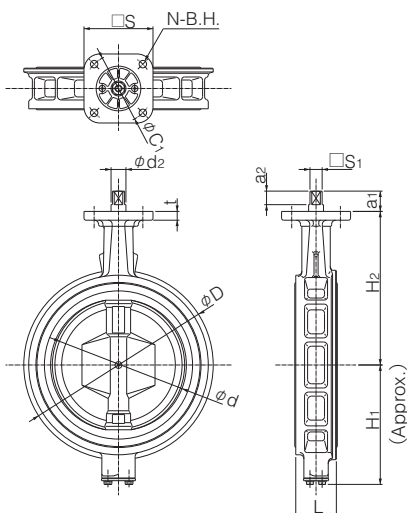

■ 732P (20K)
350mm, 400mm

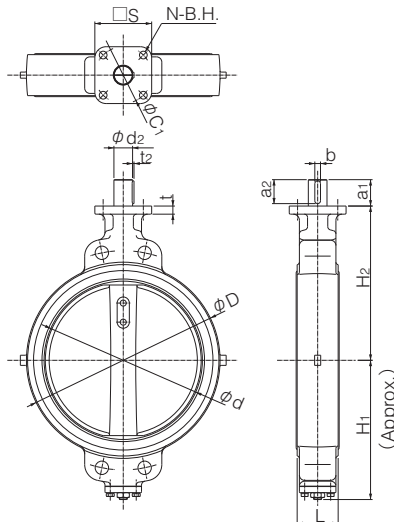

■ 732P (20K)
450mm to 600mm

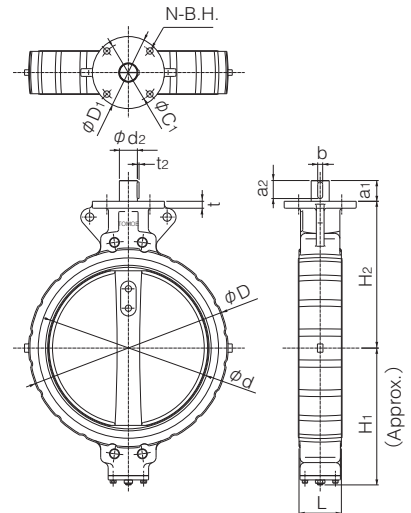

Butterfly Valve

TRITEC

TT2

334A

344Q

302A/303Q

304A/304Q

304YA

302Y/304Y

304M (HLV)

507V/508V

DTM

846T/847T/847Q

841T/842T

700Z

700G/704G/705G

72WG/72SG/72LG

731P/732P/732Q/752W

731R

700E/700K/700S

704G/722F/720F

227P

907T/908H (MKT)

903L/901C/905C (Beta-check)

731P/732P (Wafer) 732Q/752W (Lugged)

Lock lever type 731P-1T (50mm to 200mm)

731P-1T

Nominal size		Dimension (mm)								Lever type	Approx. Mass (kg)
mm	inch	ϕd	ϕD		L	H ₁	H ₂	H ₃	W		
			JIS10K	JIS16K							
50	2	54	102	102	43	68	138	66	200	1T-1	2.4
65	2 1/2	67	122	122	46	79	151	66	200	1T-1	2.8
80	3	82	132	138	46	86	156	66	200	1T-1	3.4
100	4	103	157	163	52	103	167	66	200	1T-1	4.2
125	5	129	188	200	56	118	191	92	300	1T-2	7.1
150	6	152	218	235	56	135	202	92	300	1T-2	9.1
200	8	198	267	280	60	177	227	97	350	1T-3	13.2

Lock lever type 732P-1T (50mm to 200mm)

732P-1T

Nominal size		Dimension (mm)							Lever type	Approx. Mass (kg)
mm	inch	ϕd	ϕD	L	H ₁	H ₂	H ₃	W		
50	2	54	102	43	68	138	66	200	1T-1	2.5
65	2 1/2	67	122	46	79	151	66	200	1T-1	2.9
80	3	82	138	46	86	156	66	200	1T-1	3.6
100	4	103	163	52	103	167	66	200	1T-1	4.4
125	5	129	200	56	118	191	92	300	1T-2	7.4
150	6	152	235	56	135	202	92	300	1T-2	9
200	8	198	280	60	177	227	97	350	1T-3	13.8

731P/732P-1T

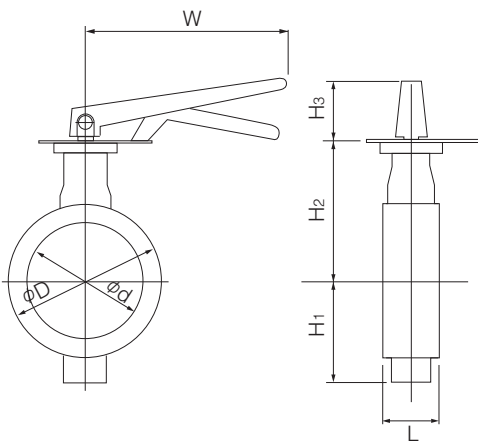

Worm gear type 731P-2I(50mm to 300mm)/731P-2U(350mm, 400mm)/731P-2S(450mm to 600mm)

■ 731P

Type	Nominal size		Dimension (mm)											Gear type	Approx. Mass (kg)
	mm	inch	ϕd	ϕD		L	H ₁	H ₂	H ₃	E	K	F	W		
				JIS10K	JIS16K										
731P	50	2	54	102	102	43	68	138	24	28	35	83	70	21-0	2.4
	65	2 1/2	67	122	122	46	79	151	24	28	35	83	70	21-0	2.8
	80	3	82	132	138	46	86	156	27	46	48	145	100	21-1	4.1
	100	4	103	157	163	52	103	167	27	46	48	145	100	21-1	4.8
	125	5	129	188	200	56	118	191	30	53	51	160	125	21-2	7.7
	150	6	152	218	235	56	135	202	30	53	51	160	125	21-2	9.7
	200	8	198	267	280	60	177	227	36	71	65	208	200	21-3	15.5
	250	10	251	330	353	68	216	280	36	71	65	193	200	21-3	24.3
	300	12	300	375	403	78	254	312	38.5	71	65	193	200	21-4	34.1
	350	14	336	415	415	78	304	340	50	90	105	266	280	2U-5	90
	400	16	390	477	477	102	343	380	50	90	105	266	280	2U-5	126
	450	18	439	532	532	114	379	420	55	117	164	335	355	MGH-3	172
	500	20	490	610	610	127	422	450	55	117	164	335	355	MGH-3	222
600	24	583	826	720	154	494	530	65	140	198	400	450	MGH-4	378(408)	

Remark: Value in brackets is for JIS 10K flanges.

■ 731P-2 I/2U/2S

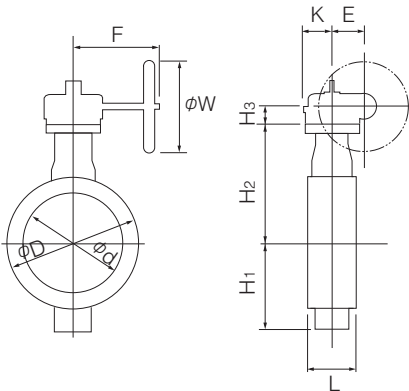

■ 2I Installation direction

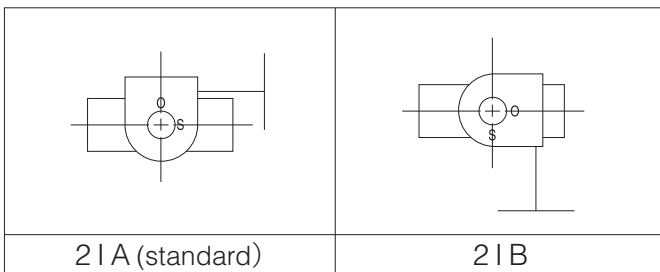

■ 2U/2S Installation direction

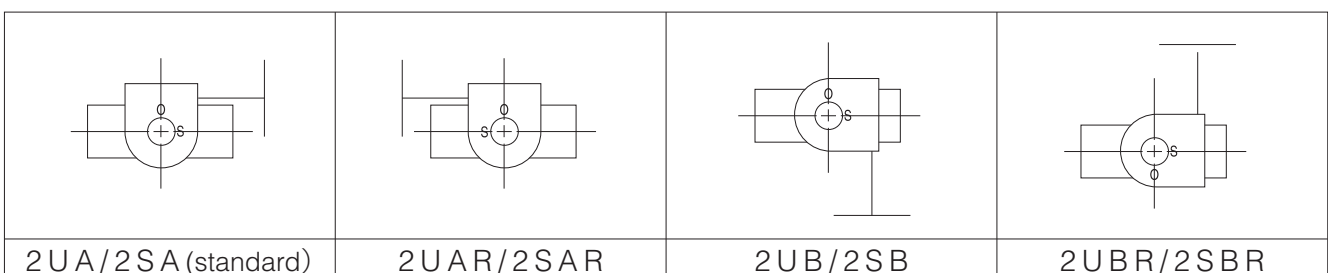

Butterfly Valve
TRITEC
TT2
334A
344Q
302A/303Q
304A/304Q
304YA
302Y/304Y
304M (HLV)
507V/508V
DTM
846T/847T/847Q
841T/842T
700Z
700G/704G/705G
72WG/72SG/72LG
731P/732P/732Q/752W
731R
700E/700K/700S
704G/722F/720F
227P
907T/908H (MKT)
903L/901C/905C (Bata-check)

731P/732P (Wafer) 732Q/752W (Lugged)

Worm gear type 732P-2I (50mm to 300mm) / 732P-2U (350mm, 400mm) / 732P-2S (450mm to 600mm)

732P

Type	Nominal size		Dimension (mm)										Gear type	Approx. Mass (kg)
	mm	inch	ϕd	ϕD	L	H ₁	H ₂	H ₃	E	K	F	W		
732P	50	2	54	102	43	68	138	24	28	35	83	70	2I-0	2.4
	65	2 1/2	67	122	46	79	151	24	28	35	83	70	2I-0	2.9
	80	3	82	138	46	86	156	27	46	48	145	100	2I-1	4.2
	100	4	103	163	52	103	167	27	46	48	145	100	2I-1	5
	125	5	129	200	56	118	191	30	53	51	160	125	2I-2	8
	150	6	152	235	56	135	202	30	53	51	160	125	2I-2	9.6
	200	8	198	280	60	177	227	36	71	65	208	200	2I-3	16
	250	10	251	353	68	216	280	36	71	65	193	200	2I-3	25
	300	12	300	403	78	254	312	38.5	71	65	193	200	2I-4	34
	350	14	336	415	78	304	340	50	90	105	266	280	2U-5	90
	400	16	390	477	102	343	380	50	90	105	266	280	2U-5	126
	450	18	439	532	114	379	420	55	117	164	335	355	MGH-3	172
	500	20	490	610	127	422	450	55	117	164	335	355	MGH-3	222
600	24	583	720	154	494	530	65	140	198	400	450	MGH-4	378	

732P-2 I/2U/2S

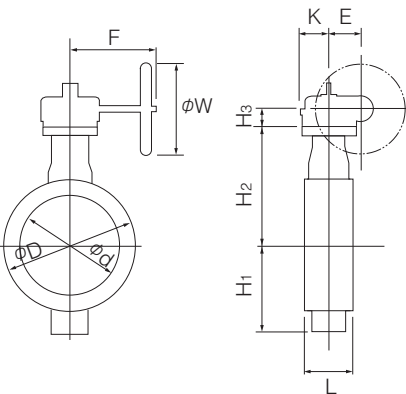

2I Installation direction

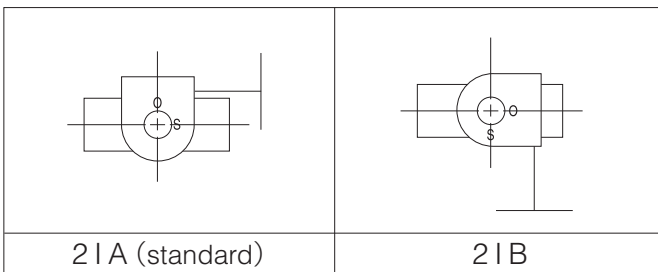

2U/2S Installation direction

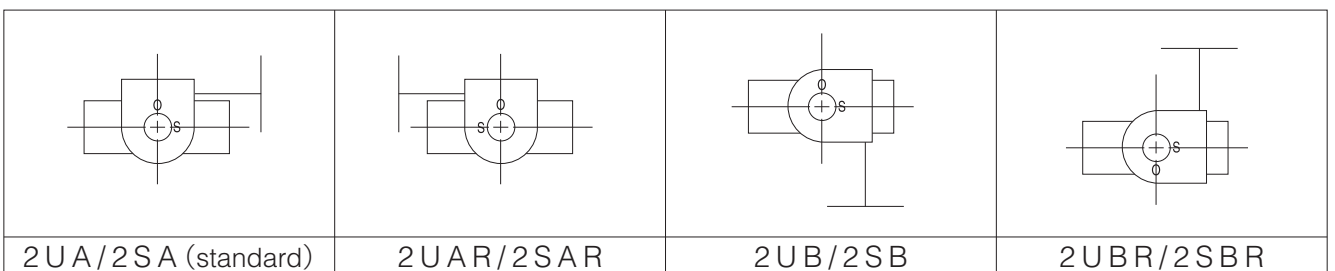

Double-acting pneumatic cylinder type 731P-7E (50mm to 300mm)

Standard

Type	Nominal size		Dimension (mm)											Cylinder type	Approx. Mass (kg)
	mm	inch	ϕd	ϕD		L	H ₁	H ₂	H ₃	A	P	f ₁	f ₂		
				JIS10K	JIS16K										
731P	50	2	54	102	102	43	68	138	125	228	116	57	29	T35	4
	65	2 1/2	67	122	122	46	79	151	125	228	116	57	29	T35	4
	80	3	82	132	138	46	86	156	125	228	116	57	29	T35	5
	100	4	103	157	163	52	103	167	168	276	142	75	47	T85	9
	125	5	129	188	200	56	118	191	203	346	176	79	57	T200	14
	150	6	152	218	235	56	135	202	203	346	176	79	57	T200	16
	200	8	198	267	280	60	177	227	231	423	214	91	69	T380	26
	250	10	251	360	353	68	216	280	231	423	214	91	69	T380	35
300	12	300	375	403	78	254	312	269	546	270	118	85	T750	53	

Heavy duty

Type	Nominal size		Dimension (mm)											Cylinder type	Approx. Mass (kg)
	mm	inch	ϕd	ϕD		L	H ₁	H ₂	H ₃	A	P	f ₁	f ₂		
				JIS10K	JIS16K										
731P	50	2	54	102	102	43	68	138	125	228	116	57	29	T35	4
	65	2 1/2	67	122	122	46	79	151	168	276	142	75	47	T85	7
	80	3	82	132	138	46	86	156	168	276	142	75	47	T85	8
	100	4	103	157	163	52	103	167	168	276	142	75	47	T85	9
	125	5	129	188	200	56	118	191	203	346	176	79	57	T200	14
	150	6	152	218	235	56	135	202	231	423	214	91	69	T380	22
	200	8	198	267	280	60	177	227	231	423	214	91	69	T380	26
	250	10	251	330	353	68	216	280	269	546	270	118	85	T750	45

Selection criteria	Standard	Heavy duty
	Select when none of the following heavy duty items apply.	Select when any of the following items apply. ① Powder or high viscosity fluid (crude oil, etc.) ② Control specification (with positioner) ③ Emergency open valve or pipe dead end valve ④ Air or Gas

731P-7E

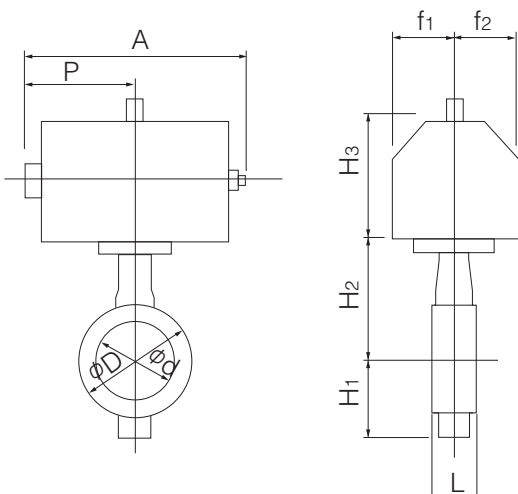

7E Installation direction

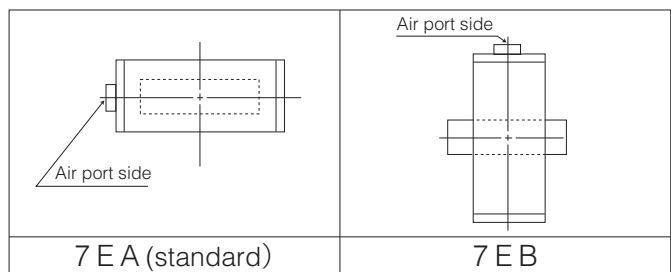

Butterfly Valve
TRITEC
TT2
334A
344Q
302A/303Q
304A/304Q
304YA
302Y/304Y
304M (HLV)
507V/508V
DTM
846T/847T/847Q
841T/842T
700Z
700G/704G/705G
72WG/72SG/72LG
731P/732P/732Q/752W
731R
700E/700K/700S
704G/722F/720F
227P
907T/908H (MKT)
903L/901C/905C (Bata-check)

731P/732P (Wafer) 732Q/752W (Lugged)

Double-acting pneumatic cylinder type 732P-7E (50mm to 300mm)

Standard

Type	Nominal size		Dimension (mm)										Cylinder type	Approx. Mass (kg)
	mm	inch	ϕd	ϕD	L	H ₁	H ₂	H ₃	A	P	f ₁	f ₂		
732P	50	2	54	102	43	68	138	125	228	116	57	29	T35	4
	65	2 1/2	67	122	46	79	151	125	228	116	57	29	T35	4
	80	3	82	138	46	86	156	168	276	142	75	47	T85	8
	100	4	103	163	52	103	167	168	276	142	75	47	T85	9
	125	5	129	200	56	118	191	203	346	176	79	57	T200	14
	150	6	152	235	56	135	202	203	346	176	79	57	T200	16
	200	8	198	280	60	177	227	231	423	214	91	69	T380	27
	250	10	251	353	68	216	280	269	546	270	118	85	T750	45
	300	12	300	403	78	254	312	269	546	270	118	85	T750	53

Heavy duty

Type	Nominal size		Dimension (mm)										Cylinder type	Approx. Mass (kg)
	mm	inch	ϕd	ϕD	L	H ₁	H ₂	H ₃	A	P	f ₁	f ₂		
732P	50	2	54	102	43	68	138	125	228	116	57	29	T35	4
	65	2 1/2	67	122	46	79	151	168	276	142	75	47	T85	7
	80	3	82	138	46	86	156	168	276	142	75	47	T85	8
	100	4	103	163	52	103	167	203	346	176	79	57	T200	12
	125	5	129	200	56	118	191	203	346	176	79	57	T200	14
	150	6	152	235	56	135	202	231	423	214	91	69	T380	22
	200	8	198	280	60	177	227	269	546	270	118	85	T750	37

Selection criteria	Standard	Select when none of the following heavy duty items apply.
	Heavy duty	Select when any of the following items apply. ① Powder or high viscosity fluid (crude oil, etc.) ② Control specification (with positioner) ③ Emergency open valve or pipe dead end valve ④ Air or Gas

732P-7E

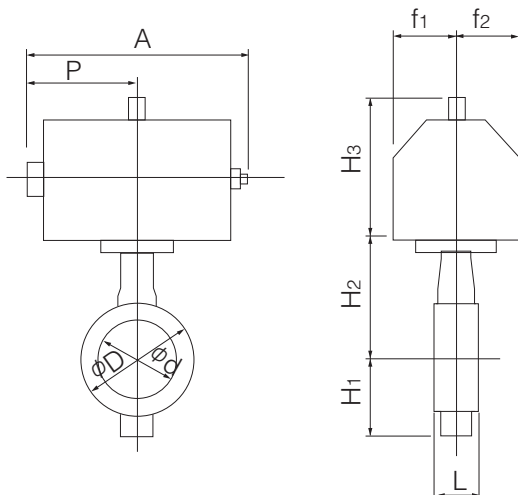

7E Installation direction

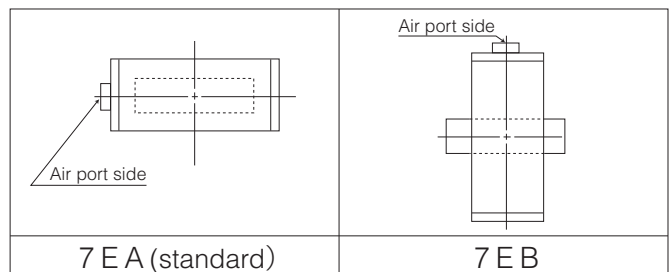

Double-acting pneumatic cylinder type 731P-3A (300mm to 600mm)

Standard

Type	Nominal size		Dimension (mm)											Cylinder type	Approx. Mass (kg)
	mm	inch	ϕd	ϕD		L	H ₁	H ₂	H ₃	A	P	f ₁	f ₂		
				JIS10K	JIS16K										
731P	350	14	336	415	415	78	304	340	364	754	381	100	164	TGA-125	108
	400	16	390	477	477	102	343	380	364	754	381	100	164	TGA-125	144
	450	18	439	532	532	114	379	420	407	840	432	100	180	TGA-140	194
	500	20	490	610	610	127	422	450	435	954	483	130	202	TGA-160	294
	600	24	583	826	720	154	494	530	570	1175	599	160	253	TGA-200	537(567)

Remark: Value in brackets is for JIS 10K flanges.

Heavy duty

Type	Nominal size		Dimension (mm)											Cylinder type	Approx. Mass (kg)
	mm	inch	ϕd	ϕD		L	H ₁	H ₂	H ₃	A	P	f ₁	f ₂		
				JIS10K	JIS16K										
731P	300	12	300	375	403	78	254	312	359	754	381	100	164	TGA-125	74
	350	14	336	415	415	78	304	340	412	840	432	100	180	TGA-140	128
	400	16	390	477	477	102	343	380	465	954	483	130	202	TGA-160	214
	450	18	439	532	532	114	379	420	478	1069	543	130	218	TGA-180	289
	500	20	490	610	610	127	422	450	570	1175	599	160	253	TGA-200	402
	600	24	583	826	720	154	494	530	633	1394	707	160	299	TGA-250	635(665)

Remark: Value in brackets is for JIS 10K flanges.

731P-3A

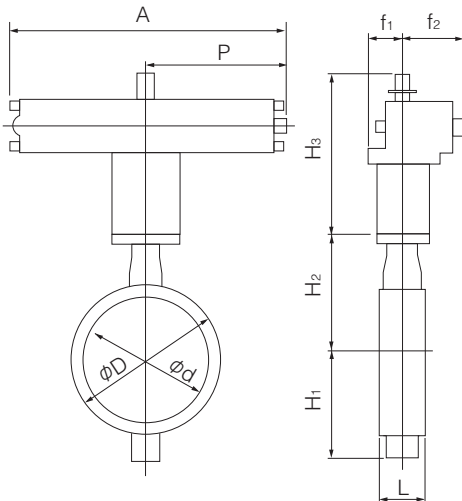

Selection criteria	Standard	Select when none of the following heavy duty items apply.
	Heavy duty	Select when any of the following items apply. ① Powder or high viscosity fluid (crude oil, etc.) ② Control specification (with positioner) ③ Emergency open valve or pipe dead end valve ④ Air or Gas

3A Installation direction

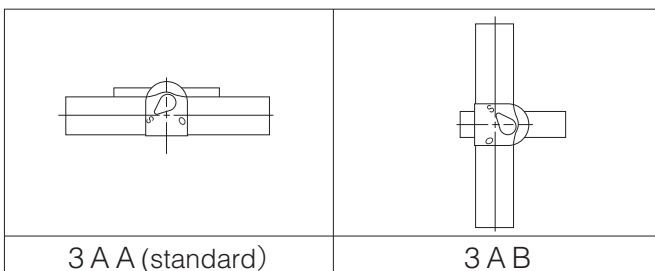

Butterfly Valve
TRITEC
TT2
334A
344Q
302A/303Q
304A/304Q
304YA
302Y/304Y
304M (HLV)
507V/508V
DTM
846T/847T/847Q
841T/842T
700Z
700G/704G/705G
72WG/72SG/72LG
731P/732P/732Q/752W
731R
700E/700K/700S
704G/722F/720F
227P
907T/908H (MKT)
903L/901C/905C (Bata-check)

731P/732P (Wafer) 732Q/752W (Lugged)

Double-acting pneumatic cylinder type 732P-3A (250mm, 300mm)

Heavy duty

Type	Nominal size		Dimension (mm)										Cylinder type	Approx. Mass (kg)
	mm	inch	ϕd	ϕD	L	H ₁	H ₂	H ₃	A	P	f ₁	f ₂		
732P	250	10	251	353	68	216	280	234	742.5	362	100	164	TGA-125	60
	300	12	300	403	78	254	312	234	742.5	362	100	164	TGA-125	74

732P-3A

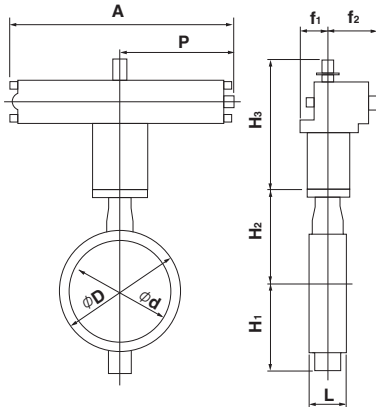

Selection criteria	Standard	Select when none of the following heavy duty items apply.
	Heavy duty	Select when any of the following items apply. ① Powder or high viscosity fluid (crude oil, etc.) ② Control specification (with positioner) ③ Emergency open valve or pipe dead end valve ④ Air or Gas

3A Installation direction

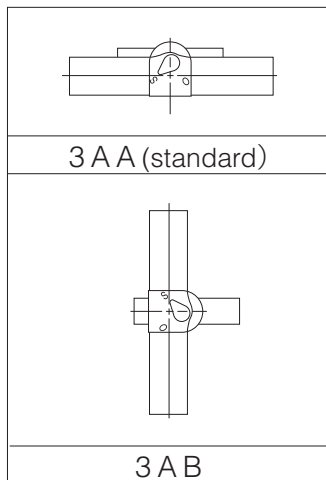

Single-acting pneumatic cylinder type 731P-7G (Air to open: 50mm to 200mm) / 731P-7F (Air to close: 50mm to 200mm)

■ Standard

Nominal size		Dimension (mm)											Cylinder type	Approx. Mass (kg)
mm	inch	φd	φD		L	H ₁	H ₂	H ₃	A	P	f ₁	f ₂		
			JIS10K	JIS16K										
50	2	54	102	102	43	68	138	168	364	183	75	47	T85S	8
65	2 1/2	67	122	122	46	79	151	168	364	183	75	47	T85S	9
80	3	82	132	138	46	86	156	168	364	183	75	47	T85S	9
100	4	103	157	163	52	103	167	203	449	226	79	57	T200S	15
125	5	129	188	200	56	118	191	231	550	276	91	69	T380S	25
150	6	152	218	235	56	135	202	269	723	360	118	85	T750S	41
200	8	198	267	280	60	177	227	269	723	360	118	85	T750S	44

■ Heavy duty

Nominal size		Dimension (mm)											Cylinder type	Approx. Mass (kg)
mm	inch	φd	φD		L	H ₁	H ₂	H ₃	A	P	f ₁	f ₂		
			JIS10K	JIS16K										
50	2	54	102	102	43	68	138	168	364	183	75	47	T85S	8
65	2 1/2	67	122	122	46	79	151	203	449	226	79	57	T200S	13
80	3	82	132	138	46	86	156	203	449	226	79	57	T200S	14
100	4	103	157	163	52	103	167	231	550	276	91	69	T380S	23
125	5	129	188	200	56	118	191	269	723	360	118	85	T750S	39
150	6	152	218	235	56	135	202	269	723	360	118	85	T750S	41

Selection criteria	Standard	Select when none of the following heavy duty items apply.
	Heavy duty	Select when any of the following items apply. ① Powder or high viscosity fluid (crude oil, etc.) ② Control specification (with positioner) ③ Emergency open valve or pipe dead end valve ④ Air or Gas

■ 731P-7G

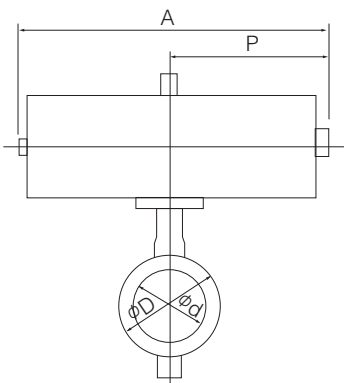

■ 731P-7F

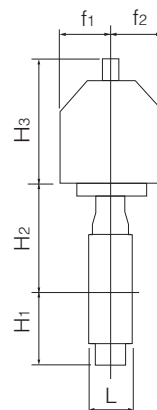
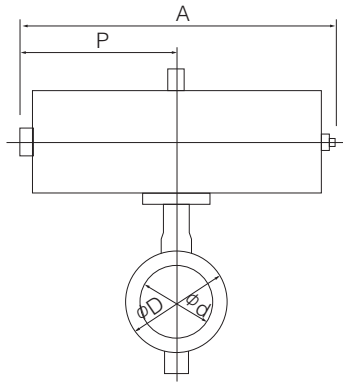

■ 7G/7F Installation direction

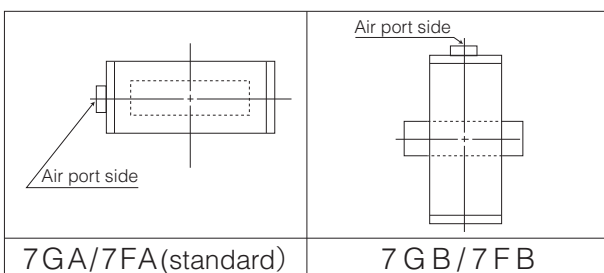

Butterfly Valve
TRITEC
TT2
334A
344Q
302A/303Q
304A/304Q
304YA
302Y/304Y
304M (HLV)
507V/508V
DTM
846T/847T/847Q
841T/842T
700Z
700G/704G/705G
72WG/72SG/72LG
731P/732P/732Q/752W
731R
700E/700K/700S
704G/722F/720F
227P
907T/908H (MKT)
903L/901C/905C (Bata-check)

731P/732P (Wafer) 732Q/752W (Lugged)

Single-acting pneumatic cylinder type 732P-7G (Air to open: 50mm to 150mm) / 732P-7F (Air to close: 50mm to 150mm)

Standard

Type	Nominal size		Dimension (mm)										Cylinder type	Approx. Mass (kg)
	mm	inch	ϕd	ϕD	L	H ₁	H ₂	H ₃	A	P	f ₁	f ₂		
732P	50	2	54	102	43	68	138	168	364	183	75	47	T85S	8
	65	2 1/2	67	122	46	79	151	203	449	226	79	57	T200S	13
	80	3	82	138	46	86	156	203	449	226	79	57	T200S	14
	100	4	103	163	52	103	167	231	550	276	91	69	T380S	23
	125	5	129	200	56	118	191	231	550	276	91	69	T380S	25
150	6	152	235	56	135	202	269	723	360	118	85	T750S	40	

Heavy duty

型式	呼び径		主要寸法 (mm)										シリンダ型式	概算質量 (kg)
	mm	inch	ϕd	ϕD	L	H ₁	H ₂	H ₃	A	P	f ₁	f ₂		
732P	50	2	54	102	43	68	138	203	449	226	79	57	T200S	13
	65	2 1/2	67	122	46	79	151	203	449	226	79	57	T200S	13
	80	3	82	138	46	86	156	203	449	226	79	57	T200S	14
	100	4	103	163	52	103	167	231	550	276	91	69	T380S	23
	125	5	129	200	56	118	191	269	723	360	118	85	T750S	39
150	6	152	235	56	135	202	269	723	360	118	85	T750S	41	

Selection criteria	Standard	Heavy duty
	Select when none of the following heavy duty items apply.	Select when any of the following items apply. ① Powder or high viscosity fluid (crude oil, etc.) ② Control specification (with positioner) ③ Emergency open valve or pipe dead end valve ④ Air or Gas

732P-7G

732P-7F

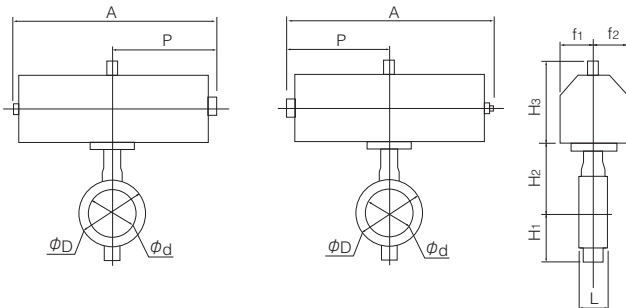

7G/7F

Installation direction

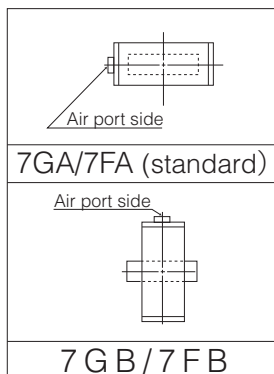

Single-acting pneumatic cylinder type 731P-3U (Air to open: 200mm to 600mm) / 731P-3K (Air to close: 200mm to 600mm)

■ Standard

Type	Nominal size		Dimension (mm)											Cylinder type	Approx. Mass (kg)
	mm	inch	φd	φD		L	H ₁	H ₂	H ₃	A	P	f ₁	f ₂		
				JIS10K	JIS16K										
731P	200	8	198	267	280	60	177	227	307	945	585	70	165	TG-10S	62
	250	10	251	330	353	68	216	280	307	1080	720	94	206	TG-12S	116
	300	12	300	375	403	78	254	312	307	1080	720	94	206	TG-12S	125
	350	14	336	415	415	78	304	340	340	1255	865	131	257	TG-14S	264
	400	16	390	477	477	102	343	380	340	1255	865	131	257	TG-14S	300
	450	18	439	532	532	114	379	420	474	1655	1095	164	348	TG-20S	555
	500	20	490	610	610	127	422	450	474	1655	1095	164	348	TG-20S	606
600	24	583	826	720	154	494	530	474	1655	1095	164	348	TG-20S	736 (766)	

Remark: Value in brackets is for JIS 10K flanges.

■ Heavy duty

Type	Nominal size		Dimension (mm)											Cylinder type	Approx. Mass (kg)
	mm	inch	φd	φD		L	H ₁	H ₂	H ₃	A	P	f ₁	f ₂		
				JIS10K	JIS16K										
731P	200	8	198	267	280	60	177	227	307	1080	720	94	206	TG-12S	107
	250	10	251	330	353	68	216	280	307	1080	720	94	206	TG-12S	116
	300	12	300	375	403	78	254	312	340	1255	865	131	257	TG-14S	226
	350	14	336	415	415	78	304	340	340	1255	865	131	257	TG-14S	264
	400	16	390	477	477	102	343	380	474	1655	1095	164	348	TG-20S	513
	450	18	439	532	532	114	379	420	474	1655	1095	164	348	TG-20S	555
	500	20	490	610	610	127	422	450	474	1655	1095	164	348	TG-20S	606

Selection criteria	Standard	Select when none of the following heavy duty items apply.
	Heavy duty	Select when any of the following items apply. ① Powder or high viscosity fluid (crude oil, etc.) ② Control specification (with positioner) ③ Emergency open valve or pipe dead end valve ④ Air or Gas

■ 731P-3U

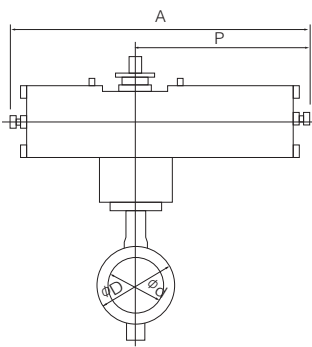

■ 731P-3K

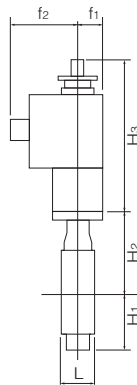
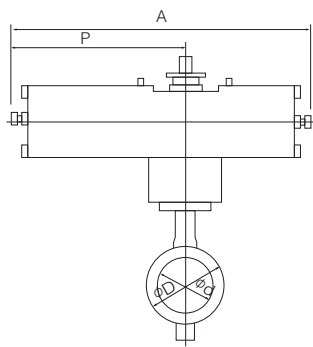

■ 3U Installation direction

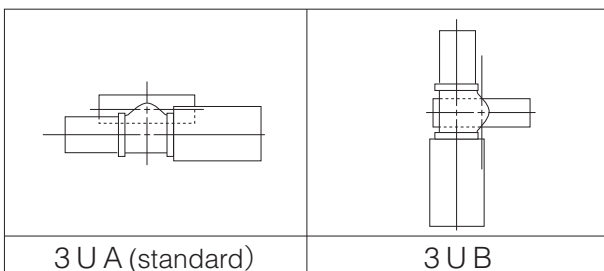

■ 3K Installation direction

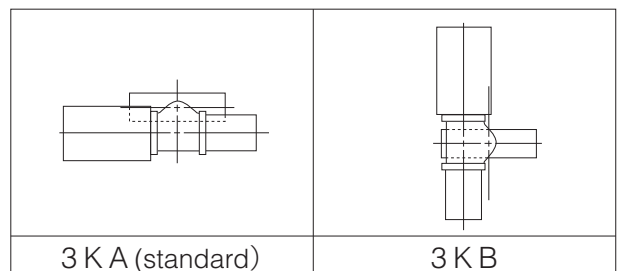

Butterfly Valve
TRITEC
TT2
334A
344Q
302A/303Q
304A/304Q
304YA
302Y/304Y
304M (HLV)
507V/508V
DTM
846T/847T/847Q
841T/842T
700Z
700G/704G/705G
72WG/72SG/72LG
731P/732P/732Q/752W
731R
700E/700K/700S
704G/722F/720F
227P
907T/908H (MKT)
903L/901C/905C (Bata-check)

731P/732P (Wafer) 732Q/752W (Lugged)

Single-acting pneumatic cylinder type 732P-3U (Air to open: 200mm to 300mm) / 732P-3K (Air to close: 200mm to 300mm)

Standard

Nominal size		Dimension (mm)										Cylinder type	Approx. Mass (kg)
mm	inch	ϕd	ϕD	L	H ₁	H ₂	H ₃	A	P	f ₁	f ₂		
200	8	198	280	60	177	227	307	945	585	70	165	TG-10S	68
250	10	251	353	68	216	280	307	1080	720	94	206	TG-12S	122
300	12	300	403	78	254	312	307	1080	720	94	206	TG-12S	130

Heavy duty

Nominal size		Dimension (mm)										Cylinder type	Approx. Mass (kg)
mm	inch	ϕd	ϕD	L	H ₁	H ₂	H ₃	A	P	f ₁	f ₂		
200	8	198	280	60	177	227	307	1080	720	94	206	TG-12S	112
250	10	251	353	68	216	280	340	1255	865	131	257	TG-14S	218
300	12	300	403	78	254	312	340	1255	865	131	257	TG-14S	226

Please consult us regarding selection of drive parts for 350mm and higher.

Selection criteria	Standard	Select when none of the following heavy duty items apply.
	Heavy duty	Select when any of the following items apply. ① Powder or high viscosity fluid (crude oil, etc.) ② Control specification (with positioner) ③ Emergency open valve or pipe dead end valve ④ Air or Gas

732P-3U

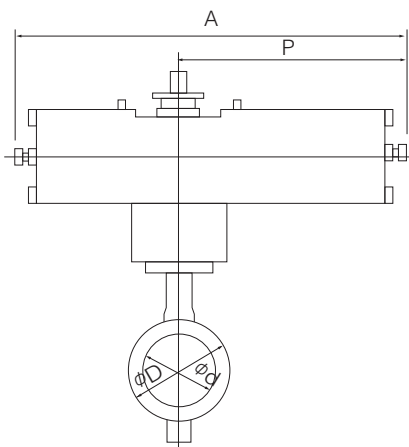

732P-3K

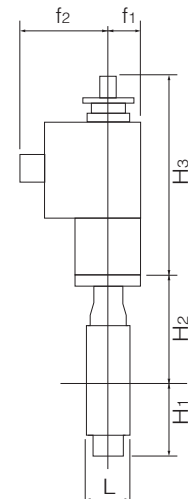
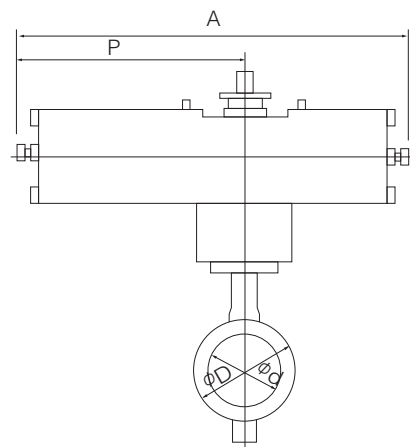

3U Installation direction

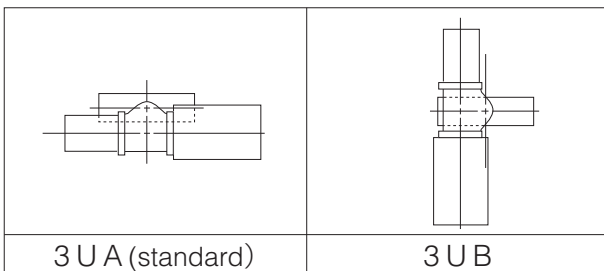

3K Installation direction

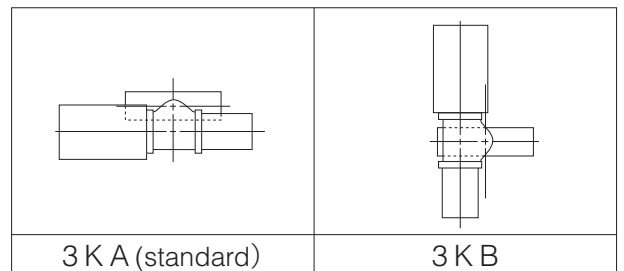

Single phase electric motor type 731P-4I(50mm to 400mm)

Type	Nominal size		Dimension (mm)											Motor type	Approx. Mass (kg)
	mm	inch	ϕd	ϕD		L	H ₁	H ₂	H ₃	A	P	F	K		
				JIS10K	JIS16K										
731P	50	2	54	102	102	43	68	138	120	161	84	58	45	4I-00	4.3
									150	202	100	85	54	4I-0	6
	65	2 1/2	67	122	122	46	79	151	150	202	100	85	54	4I-0	6.4
	80	3	82	132	138	46	86	156	150	202	100	85	54	4I-0	7
	100	4	103	157	163	52	103	167	165	252	138	126	65	4I-1	10
	125	5	129	188	200	56	118	191	198	310	167	154	85	4I-2	17
	150	6	152	218	235	56	135	202	198	310	167	154	85	4I-2	19
	200	8	198	267	280	60	177	227	198	310	167	154	85	4I-2.5	24.3
	250	10	251	330	353	68	216	280	230	388	223	246	136	4I-3	43.5
	300	12	300	375	403	78	254	312	230	388	223	246	136	4I-3	52.1
	350	14	336	415	415	78	304	340	230	388	223	246	136	4I-4	100
400	16	390	477	477	102	343	380	230	388	223	246	136	4I-4	136	

Note 1: For nominal size 50 mm type (for control), the 4I-0 type should be selected. (The 4I-00 type is only designed for ON-OFF operation.)

731P-4I

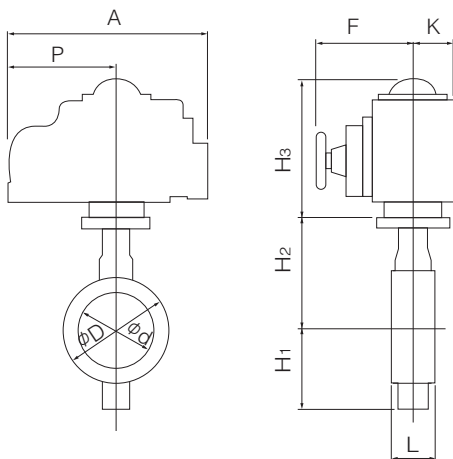

4I Installation direction

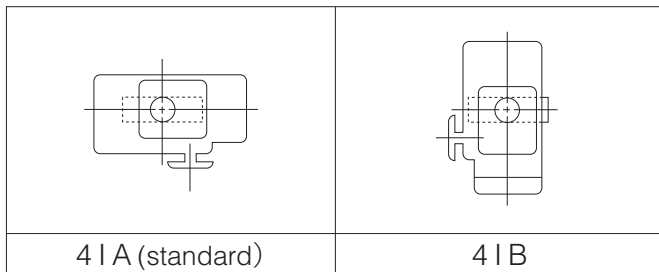

Butterfly Valve
TRITEC
TT2
334A
344Q
302A/303Q
304A/304Q
304YA
302Y/304Y
304M (HLV)
507V/508V
DTM
846T/847T/847Q
841T/842T
700Z
700G/704G/705G
72WG/72SG/72LG
731P/732P/732Q/752W
731R
700E/700K/700S
704G/722F/720F
227P
907T/908H (MKT)
903L/901C/905C (Bata-check)

731P/732P (Wafer) 732Q/752W (Lugged)

Single phase electric motor type 732P-4I (50mm to 300mm)

Nominal size		Dimension (mm)										Motor type	Approx. Mass (kg)
mm	inch	ϕd	ϕD	L	H ₁	H ₂	H ₃	A	P	F	K		
50	2	54	102	43	68	138	120	161	84	58	45	4 I-00	4.4
							150	202	100	85	54	4 I-0	6.1
65	2 1/2	67	122	46	79	151	150	202	100	85	54	4 I-0	6.5
80	3	82	138	46	86	156	150	202	100	85	54	4 I-0	7.2
100	4	103	163	52	103	167	165	252	138	126	65	4 I-1	10.2
125	5	129	200	56	118	191	198	310	167	154	85	4 I-2	17.3
150	6	152	235	56	135	202	198	310	167	154	85	4 I-2	19.1
200	8	198	280	60	177	227	230	388	223	246	136	4 I-3	35.3
250	10	251	353	68	216	280	230	388	223	246	136	4 I-3	44.2
300	12	300	403	78	254	312	230	388	223	246	136	4 I-3	52.2

Note 1: For nominal size 50 mm type (for control), the 4I-0 type should be selected. (The 4I-00 type is only designed for ON-OFF operation.)
Please consult us regarding selection of drive parts for 350mm and higher.

732P-4 I

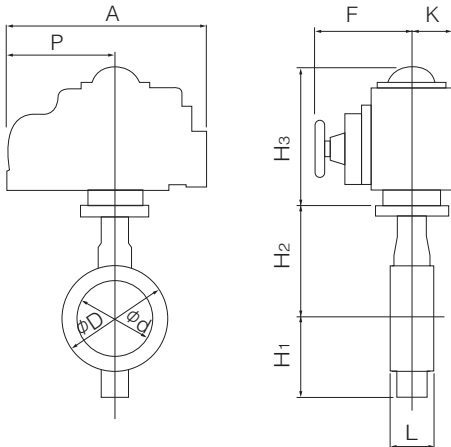

4I Installation direction

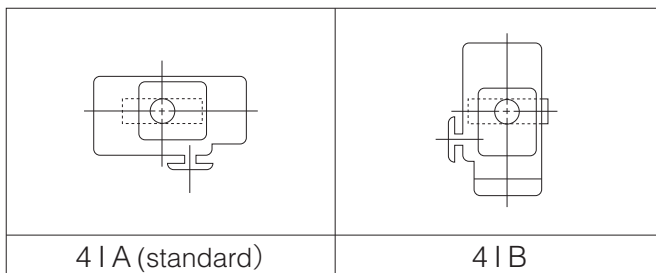

4 I A (standard)

4 I B

Three phase motor actuator type 731P-4L (300mm to 600mm)

Type	Nominal size		Dimension (mm)												Motor type	Approx. Mass (kg)
	mm	inch	ϕd	ϕD		L	H ₁	H ₂	H ₃	E	K	F	M	P		
				JIS10K	JIS16K											
731P	300	12	300	375	403	78	254	312	435	85	126	498	357	230	LTKD-01 0.2kW /MGH-2	112
	350	14	336	415	415	78	304	340	487	117	164	533	373	230	LTKD-01 0.4kW /MGH-3	178
	400	16	390	477	477	102	343	380	487	117	164	533	373	230	LTKD-01 0.4kW /MGH-3	215
	450	18	439	532	532	114	379	420	538	140	198	594	400	230	LTKD-02 0.75kW /MGH-4	297
	500	20	490	610	610	127	422	450	538	140	198	594	400	230	LTKD-02 0.75kW /MGH-4	348
	600	24	583	826	720	154	494	530	604	210	293	748	440	360	LTKD-05 0.75kW /MGH-5	645 (675)

Remark: Value in brackets is for JIS 10K flanges.

731P-4L

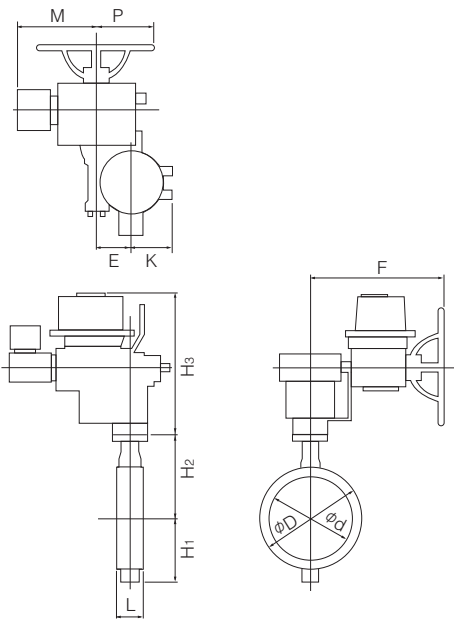

4L Installation direction

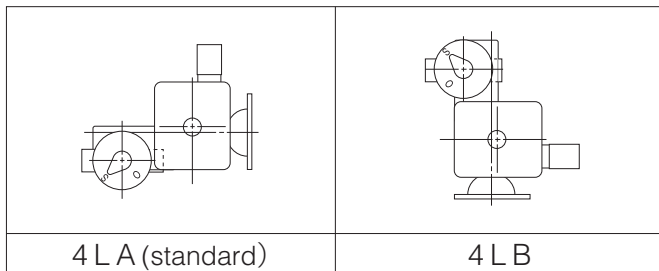

Butterfly Valve
TRITEC
TT2
334A
344Q
302A/303Q
304A/304Q
304YA
302Y/304Y
304M (HLV)
507V/508V
DTM
846T/847T/847Q
841T/842T
700Z
700G/704G/705G
72WG/72SG/72LG
731P/732P/732Q/752W
731R
700E/700K/700S
704G/722F/720F
227P
907T/908H (MKT)
903L/901C/905C (Bata-check)

731P/732P (Wafer) 732Q/752W (Lugged)

Three phase motor actuator type 732P-4L (250mm, 300mm)

Nominal size		Dimension (mm)											Motor type	Approx. Mass (kg)
mm	inch	ϕd	ϕD	L	H ₁	H ₂	H ₃	E	K	F	M	P		
250	10	251	353	68	216	280	435	85	126	498	357	230	LTKD-01 0.2kW /MGH-2	99
300	12	300	403	78	254	312	435	85	126	498	357	230	LTKD-01 0.2kW /MGH-2	110

Please consult us regarding selection of drive parts for 350mm and higher.

732P-4L

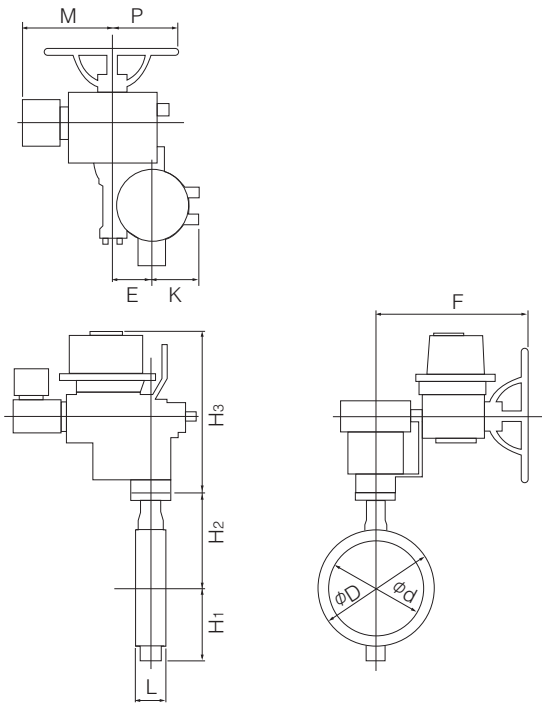

4L Installation direction

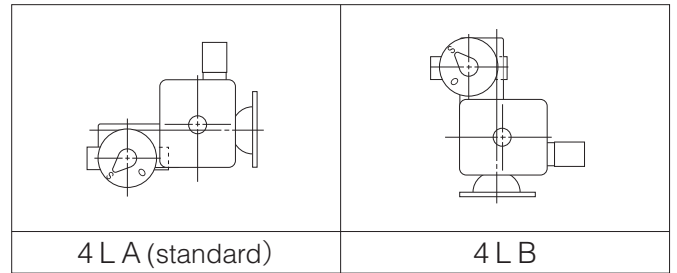

731P Cv value/Pressure loss coefficient

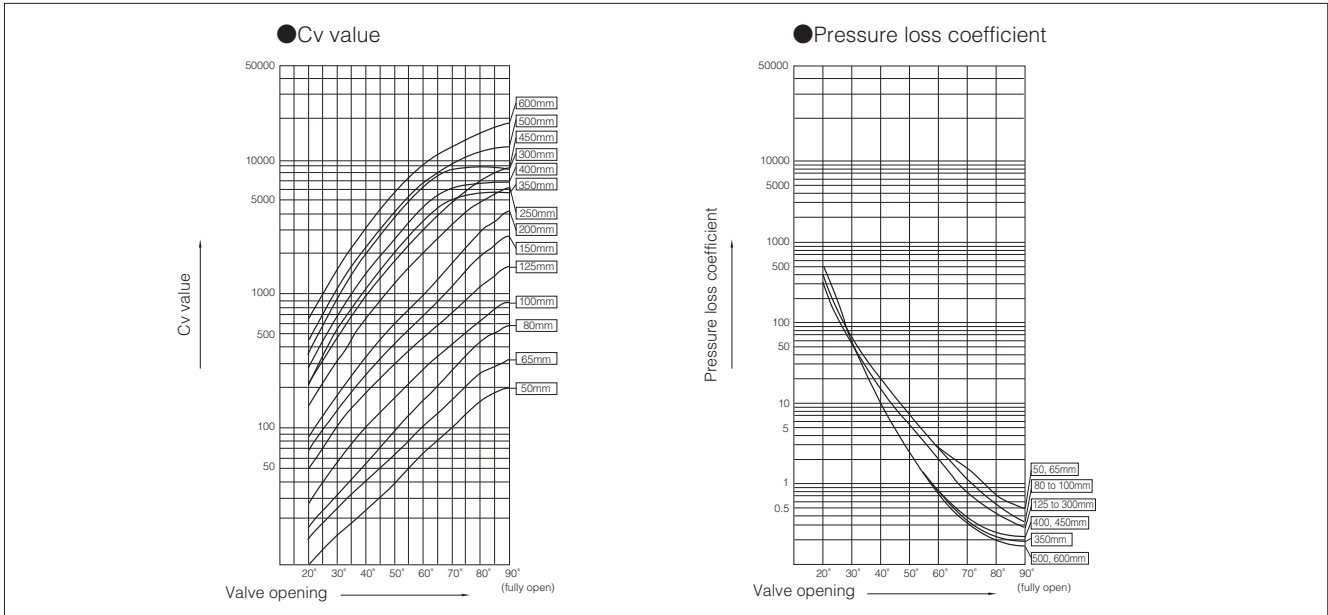

Butterfly Valve

TRITEC

TT2

334A

344Q

302A/303Q

304A/304Q

304YA

302Y/304Y

304M (HLV)

507V/508V

DTM

846T/847T/847Q

841T/842T

700Z

700G/704G/705G

72WG/72SG/72LG

731P/732P/732Q/752W

731R

700E/700K/700S

704G/722F/720F

227P

907T/908H (MKT)

903L/901C/905C (Bata-check)

731P(50mm~600mm) Cv value

Type	Nominal size		Valve opening							
	mm	inch	20°	30°	40°	50°	60°	70°	80°	90°
731P	50	2	10	17	25	37	66	102	159	200
	65	2 1/2	16	27	41	64	103	162	260	320
	80	3	20	35	57	97	162	272	450	580
	100	4	32	62	103	164	276	431	628	880
	125	5	55	107	193	297	450	727	1150	1590
	150	6	71	145	264	439	671	1170	1910	2800
	200	8	96	189	344	606	957	1730	2940	4300
	250	10	174	340	707	1240	2160	3330	4880	6200
	300	12	254	491	1000	1780	3020	4910	7180	8900
	350	14	222	548	1101	1930	3080	4431	5451	5770
	400	16	289	717	1429	2515	3924	5482	6586	6920
	450	18	365	911	1807	3182	4953	6896	8262	8670
	500	20	457	1123	2265	3975	6395	9311	11571	12300
600	24	664	1614	3307	5797	9328	13698	17243	18400	

731P(50mm~600mm) Pressure loss coefficient

Type	Nominal size		Valve opening							
	mm	inch	20°	30°	40°	50°	60°	70°	80°	90°
731P	50	2	165	61	26	13	4	2	1	0.4
	65	2 1/2	162	58	24	10	4	2	1	0.4
	80	3	196	67	25	9	3	1	0.4	0.2
	100	4	233	61	22	9	3	1	0.6	0.3
	125	5	181	48	15	6	3	1	0.4	0.2
	150	6	222	53	16	6	2	1	0.3	0.1
	200	8	373	96	29	9	4	1	0.4	0.2
	250	10	270	71	16	5	2	1	0.3	0.2
	300	12	262	70	17	5	2	1	0.3	0.2
	350	14	579	95	24	8	3	1	1	1
	400	16	596	97	24	8	3	2	1	1
	450	18	609	98	25	8	3	2	1	1
	500	20	600	99	24	8	3	1	1	1
600	24	603	102	24	8	3	1	1	1	

731P/732P (Wafer) 732Q/752W (Lugged)

732P Cv value/Pressure loss coefficient

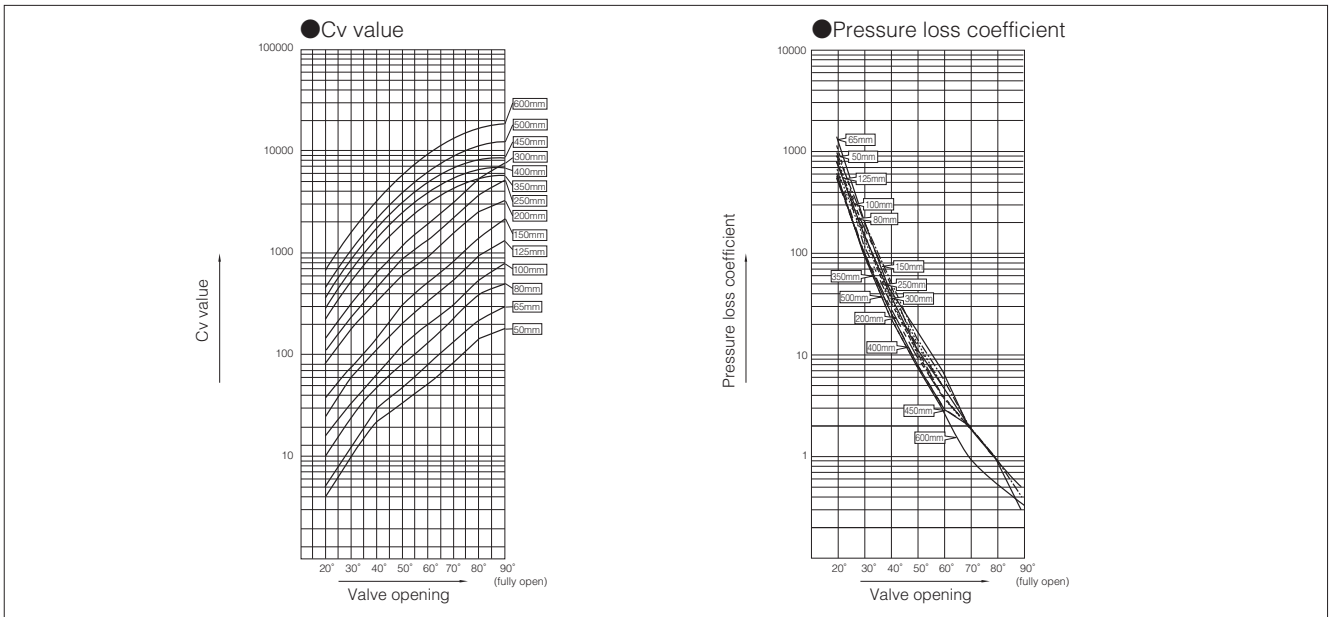

732P (50mm~600mm) Cv value

Type	Nominal size		Valve opening							
	mm	inch	20°	30°	40°	50°	60°	70°	80°	90°
731P	50	2	4	10	22	33	51	85	145	179
	65	2 1/2	5	13	30	48	79	129	220	293
	80	3	10	25	49	80	130	225	396	500
	100	4	16	33	65	125	200	311	539	772
	125	5	25	60	112	201	338	535	951	1295
	150	6	37	77	145	303	517	807	1400	2166
	200	8	79	178	335	592	906	1557	2573	3248
	250	10	110	238	460	876	1359	2217	3763	5153
	300	12	146	321	640	1192	1910	3147	5379	7546
	350	14	222	548	1101	1930	3080	4431	5451	5770
	400	16	289	717	1429	2515	3924	5482	6586	6920
	450	18	365	911	1807	3182	4953	6896	8262	8670
	500	20	457	1123	2265	3975	6395	9311	11571	12300
600	24	664	1614	3307	5797	9328	13698	17243	18400	

732P (50mm~600mm) Pressure loss coefficient

Type	Nominal size		Valve opening							
	mm	inch	20°	30°	40°	50°	60°	70°	80°	90°
731P	50	2	1132	170	35	15	6	2	1	0.5
	65	2 1/2	1389	225	45	18	7	2	1	0.5
	80	3	896	124	33	13	5	2	1	0.3
	100	4	971	214	56	15	6	2	1	0.4
	125	5	887	154	44	14	5	2	1	0.3
	150	6	801	189	53	12	4	2	1	0.3
	200	8	549	108	31	10	4	2	1	0.3
	250	10	675	145	39	11	4	2	1	0.3
	300	12	790	164	41	12	5	2	1	0.3
	350	14	579	95	24	8	3	1	1	1
	400	16	596	97	24	8	3	2	1	1
	450	18	609	98	25	8	3	2	1	1
	500	20	600	99	24	8	3	1	1	1
600	24	603	102	24	8	3	1	1	1	

731P Flange accommodation

Type	Nominal size		JIS		ASME	BS4504		DIN	
	mm	inch	10K	16K	class 150	PN10	PN16	NP10	NP16
731P	50	2	○	○	○	○	○	○	○
	65	2 1/2	○	○	○	○	○	○	○
	80	3	△	○	△	○	○	○	○
	100	4	△	○	○	○	○	○	○
	125	5	△	○	△	△	△	△	△
	150	6	△	○	△	△	△	△	△
	200	8	△	○	△	△	△	△	△
	250	10	△	○	△	△	△	△	△
	300	12	△	○	○	△	△	△	△
	350	14	D	D	D	D	D	D	D
	400	16	D	D	D	D	D	D	D
	450	18	D	D	D	D	D	D	D
	500	20	D	D	D	D	D	D	D
600	24	T	T	T	D	T	D	T	

- : Can be used without flange drilling.
- △ : With additional flange drilling.
- D : With flange drilling.
- T : With flange tapping.

732P Flange accommodation

Type	Nominal size		JIS 20K	DIN NP25
	mm	inch		
732P	50	2	○	○
	65	2 1/2	○	○
	80	3	○	○
	100	4	○	○
	125	5	○	○
	150	6	○	△
	200	8	○	○
	250	10	○	△
	300	12	○	△
	350	14	D	D
	400	16	D	D
	450	18	D	D
	500	20	D	D
600	24	T	T	

- : Can be used without flange drilling.
- △ : With additional flange drilling.
- D : With flange drilling.
- T : With flange tapping.

Butterfly Valve
TRITEC
TT2
334A
344Q
302A/303Q
304A/304Q
304YA
302Y/304Y
304M (HLV)
507V/508V
DTM
846T/847T/847Q
841T/842T
700Z
700G/704G/705G
72WG/72SG/72LG
731P/732P/732Q/752W
731R
700E/700K/700S
704G/722F/720F
227P
907T/908H (MKT)
903L/901C/905C (Bata-check)

731P/732P (Wafer) 732Q/752W (Lugged)

731P Applicable pipe list in case of **A**

Type	Nominal size		SGP	STPY	Sch20	Sch40	Sch10S	Sch20S	Minimum internal diameter of piping (mm)
	mm	inch							
731P	50	2	○	—	○	○	○	○	34
	65	2 1/2	○	—	○	○	○	○	51
	80	3	○	—	○	○	○	○	70
	100	4	○	—	○	○	○	○	91
	125	5	○	—	○	○	○	○	118
	150	6	○	—	○	○	○	○	144
	200	8	○	—	○	○	○	○	194
	250	10	○	—	○	○	○	○	246
	300	12	○	—	○	○	○	○	294
	350	14	○	○	○	○	—	—	332
	400	16	○	○	○	○	—	—	379
	450	18	○	○	○	○	—	—	428
	500	20	○	○	○	○	—	—	477
600	24	—	○	○	○	—	—	567	

731P Applicable pipe list in case of **B**

Type	Nominal size		SGP	STPY	Sch20	Sch40	Sch10S	Sch20S
	mm	inch						
731P	50	2	○	—	○	○	○	○
	65	2 1/2	○	—	○	○	○	○
	80	3	○	—	○	○	○	○
	100	4	○	—	○	○	○	○
	125	5	○	—	○	○	○	○
	150	6	○	—	○	○	○	○
	200	8	○	—	○	○	○	○
	250	10	○	—	○	○	○	○
	300	12	○	—	○	○	○	○
	350	14	○	○	○	○	—	—
	400	16	○	○	○	○	—	—
	450	18	○	○	○	○	—	—
	500	20	○	○	○	○	—	—
600	24	—	○	○	○	—	—	

Remark 1: ○=Applicable

Remark 2: Butterfly valves are inserted into a pipe that was fitted with the disc when fully open.
 In cases where you are using a pipe or flange that is less than the minimum inner pipe diameter, use is still possible if means are taken such as inserting a spacer between the valve and flange.
 For details, please consult us.

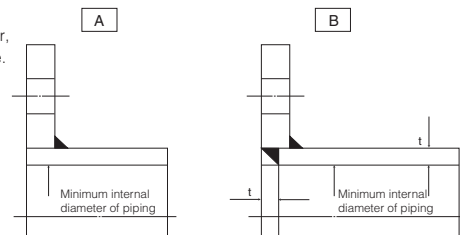

732P Applicable pipe list in case of **A**

Type	Nominal size		SGP	STPY	Sch20	Sch40	Sch20S	Minimum internal diameter of piping (mm)
	mm	inch						
732P	50	2	○	—	○	○	○	34
	65	2 1/2	○	—	○	○	○	51
	80	3	○	—	○	○	○	70
	100	4	○	—	○	○	○	91
	125	5	○	—	○	○	○	118
	150	6	○	—	○	○	○	144
	200	8	○	—	○	○	○	194
	250	10	○	—	○	○	○	246
	300	12	○	—	○	○	○	294
	350	14	○	○	○	○	—	332
	400	16	○	○	○	○	—	379
	450	18	○	○	○	○	—	428
	500	20	○	○	○	○	—	477
	600	24	—	○	○	○	—	569

732P Applicable pipe list in case of **B**

Type	Nominal size		SGP	STPY	Sch20	Sch40	Sch20S
	mm	inch					
732P	50	2	○	—	○	○	○
	65	2 1/2	○	—	○	○	○
	80	3	○	—	○	○	○
	100	4	○	—	○	○	○
	125	5	○	—	○	○	○
	150	6	○	—	○	○	○
	200	8	○	—	○	○	○
	250	10	○	—	○	○	○
	300	12	○	—	○	○	○
	350	14	○	○	○	○	—
	400	16	○	○	○	○	—
	450	18	○	○	○	○	—
	500	20	○	○	○	○	—
	600	24	—	○	○	○	—

Remark 1: ○=Applicable

Remark 2: Butterfly valves are inserted into a pipe that was fitted with the disc when fully open. In cases where you are using a pipe or flange that is less than the minimum inner pipe diameter, use is still possible if means are taken such as inserting a spacer between the valve and flange. For details, please consult us.

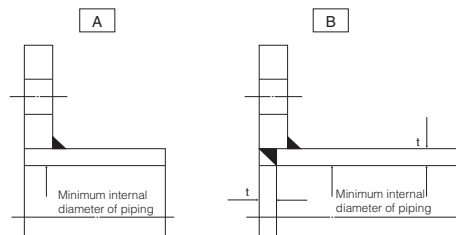

Butterfly Valve
TRITEC
TT2
334A
344Q
302A/303Q
304A/304Q
304YA
302Y/304Y
304M (HLV)
507V/508V
DTM
846T/847T/847Q
841T/842T
700Z
700G/704G/705G
72WG/72SG/72LG
731P/732P/732Q/752W
731R
700E/700K/700S
704G/722F/720F
227P
907T/908H (MKT)
903L/901C/905C (Bata-check)

731P Piping bolt and nut sizes

Hexagon bolt & nut

Type	Nominal size		JIS 10K		JIS 16K	
	mm	inch	Hexagon bolts	Setting bolts	Hexagon bolts	Setting bolts
731P	50	2	4-M16×105×40	—	8-M16× 95×35	—
	65	2 1/2	4-M16×105×40	—	8-M16×105×35	—
	80	3	8-M16×110×40	—	8-M20×110×35	—
	100	4	8-M16×110×40	—	8-M20×120×35	—
	125	5	8-M20×120×50	—	8-M22×130×40	—
	150	6	8-M20×130×50	—	12-M22×130×40	—
	200	8	12-M20×135×50	—	12-M22×140×40	—
	250	10	12-M22×150×60	—	12-M24×155×50	—
	300	12	16-M22×160×60	—	16-M24×170×50	—
	350	14	16-M22×160×60	—	16-M30(P3)×180×55	—
	400	16	16-M24×190×45	—	16-M30(P3)×215×55	—
	450	18	20-M24×205×45	—	20-M30(P3)×230×55	—
	500	20	20-M24×215×45	—	20-M30(P3)×245×55	—
600	24	20-M30×260×50	8-M30× 70×60	20-M36(P3)×285×65	8-M36(P3)×85	

Long bolt & nut

Type	Nominal size		JIS 10K		JIS 16K	
	mm	inch	Long bolts and nuts	Setting bolts	Long bolts and nuts	Setting bolts
731P	50	2	4-M16×120×30	—	8-M16×125	—
	65	2 1/2	4-M16×125×30	—	8-M16×125	—
	80	3	8-M16×125×30	—	8-M20×135	—
	100	4	8-M16×130×30	—	8-M20×150	—
	125	5	8-M20×150×40	—	8-M22×165	—
	150	6	8-M20×150×40	—	12-M22×165	—
	200	8	12-M20×160×40	—	12-M22×170	—
	250	10	12-M22×170×45	—	12-M24×190	—
	300	12	16-M22×185×45	—	16-M24×210	—
	350	14	16-M22×185×45	—	16-M30(P3)×225	—
	400	16	16-M24×220×50	—	16-M30(P3)×260	—
	450	18	20-M24×235×50	—	20-M30(P3)×280	—
	500	20	20-M24×250×50	—	20-M30(P3)×295	—
600	24	20-M30×300×60	8-M30×70×65	20-M36(P3)×340	8-M36(P3)×85	

Example

Long bolts: 12 - M22 × 185 × 45
 N M L S

Setting bolts: 4 - M30 × 95 × 65
 (Hexagon bolts) N M L S

Long bolts and nuts (full thread)

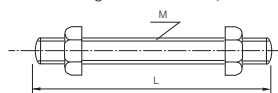

Setting bolts (Hexagon bolts)

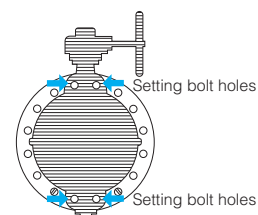
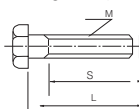

732P Piping bolt and nut sizes

Type	Nominal size		JIS 20K	
	mm	inch	Long bolts and nuts	Setting bolts
732P	50	2	8-M16×125	—
	65	2 1/2	8-M16×125	—
	80	3	8-M20×135	—
	100	4	8-M20×150	—
	125	5	8-M22×165	—
	150	6	12-M22×165	—
	200	8	12-M22×170	—
	250	10	12-M24×190	—
	300	12	16-M24×210	—
	350	14	16-M30 (P3)×225	—
	400	16	16-M30 (P3)×260	—
	450	18	20-M30 (P3)×280	—
	500	20	20-M30 (P3)×295	—
	600	24	20-M36 (P3)×340	8-M36 (P3)×90

Example

Long bolts: 12 - M22 × 185
 | | |
 M L S

Setting bolts: 4 - M30 × 95 × 65
 (Hexagon bolts) | | | |
 N M L S

Long bolts and nuts (full thread)

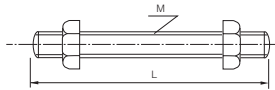

Setting bolts (Hexagon bolts)

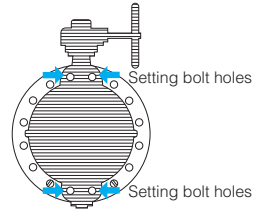
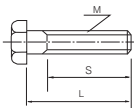

Butterfly Valve
TRITEC
TT2
334A
344Q
302A/303Q
304A/304Q
304YA
302Y/304Y
304M (HLV)
507V/508V
DTM
846T/847T/847Q
841T/842T
700Z
700G/704G/705G
72WG/72SG/72LG
731P/732P/732Q/752W
731R
700E/700K/700S
704G/722F/720F
227P
907T/908H (MKT)
903L/901C/905C (Bata-check)

731R

Valve nominal size

350 to 600mm

Max. working pressure MPa

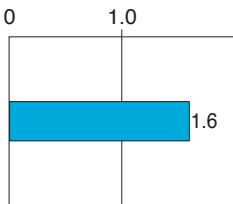

Working temperature range °C

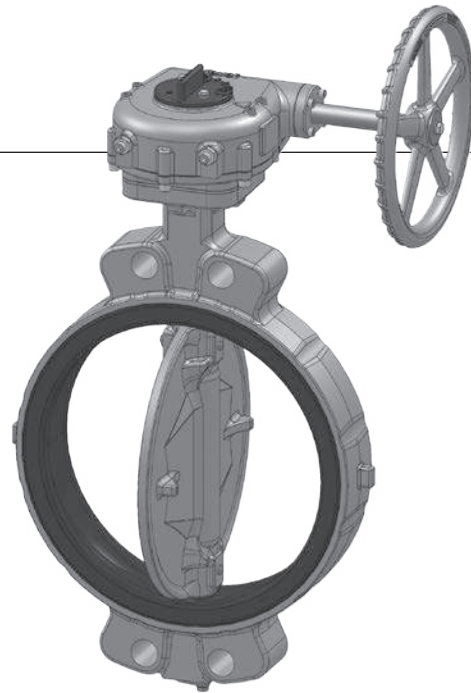
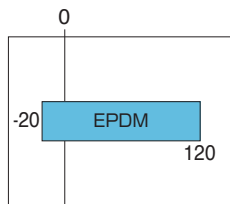

Features and Benefits

Adaptable for Building Services for Super High-rise Buildings and High-pressure Lines for Utilities Facilities.
Concentric Butterfly Valve for High Pressure Service with Excellent Cost Performance.

- New lineup of models from 350 mm to 600 mm (1.6 Mpa)
- In compliance with JIS and ISO face-to-face dimensions
- Globally-patented cosine curve seat ring
- Significantly improved durability thanks to spherical disc
- Self-aligning stem seal through secondary seal ring

Light and compact

Weight reduced by 34% compared to the previous product*1

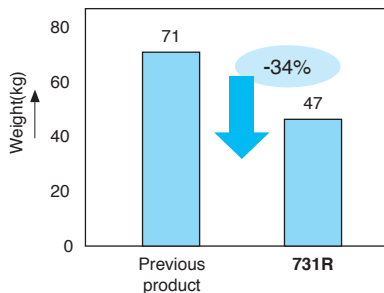

*1 In comparison with the previous 350 mm bore-size product Model 731P

Condensation protection measures *Optional

No condensation in the gear at ambient temperature 34°C and humidity 75% with cold water at 5°C.

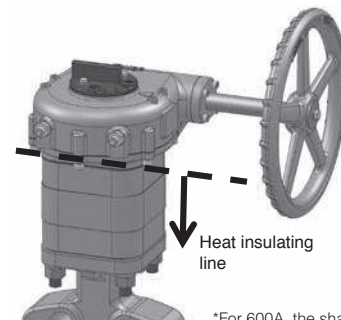

*For 600A, the shape is different.

Standard Specifications

Valve model	731R	
Body type (centering method)	Concentric design, wafer type	
Valve nominal size	350mm to 600mm	
Face-to-face dimensions	JIS B 2002 46 series / ISO5752 wafer butterfly valve (short)	
Flange accommodation	JIS 16K, ASME Class 150	
Max. working pressure *3	1.6 MPa	
Allowable valve seat leakage standard	Tight shut-off	
Pressure application direction (flow direction)	Bi-direction	
Test pressure	Body shell test	JIS 16K, ASME Class 150: 2.4 MPa
	Seat leakage	JIS 16K, ASME Class 150: 1.76 MPa Hydraulic
Working temperature range	EPDM: -20 to 120°C (Please consult us when using the product in the temperature range -20°C to 0°C.)	
Working temperature in continuous use *2	EPDM: 0 - 70°C	
Allowable average pipe flow velocity (limit value)	3 m/s or less (At full valve open, continuous operation)	
Standard materials	Body	FCD450
	Disc	SCS13
	Stem	SUS420J2
	Seat ring *1	EPDM
Top flange	In compliance with ISO5211/1	
Condensation prevention structure	Optional (Condensation prevention resin column)	
Piping gasket	Not necessary	
Coating	Epoxy primer (Munsell N7)	
Actuator	Worm gear type (Automatic valves are not supported.)	

Note) If the following specifications are required, please consult our sales office.

- (1) High durability required because the number of opening/closing times exceeds 100,000.
- (2) Continuous operation required with a valve opening angle of 30 degrees or less.
- (3) Control operation which requires 3% or lower hysteresis accuracy of the valve itself.

*1 If the fluid contains chlorine, the seat ring may deteriorate early due to combined factors including concentration and temperature. For details consult our sales office.

*2 "Working temperature in continuous use" is the temperature range when the valve is operated continuously over one hour. If the valve is operated continuously at a temperature above 70°C and there is no problem, we advise that the valve can be used in that environment.

*3 Negative pressure range is not allowable.

Standard Specifications

Material Name	EPDM	
Temperature range	Allowable (°C)	-20~120
	Continuous (°C)	0~70
Max. working pressure(Mpa)	1.6	
Color	Black	
Features	Corrosion resistance	○
	Heat resistance	○
	Grease resistance	×
	Abrasion resistance	△

Key to symbols ○………… Good - Fit for use
△………… Acceptable for use
×………… Not fit for use

Note 1) If the fluid contains oil, never use EPDM.

Note 2) ○,△ and × in the above features show typical characteristics.
The characteristics depend on fluid and temperature conditions.
Please consult us.

Butterfly Valve
TRITEC
TT2
334A
344Q
302A/303Q
304A/304Q
304YA
302Y/304Y
304M (HLV)
507V/508V
DTM
846T/847T/847Q
841T/842T
700Z
700G/704G/705G
72WG/72SG/72LG
731P/732P/732Q/752W
731R
700E/700K/700S
704G/722F/720F
227P
907T/908H (MKT)
903L/901C/905C (Bata-check)

731R Expanded view of components / 731R Parts list

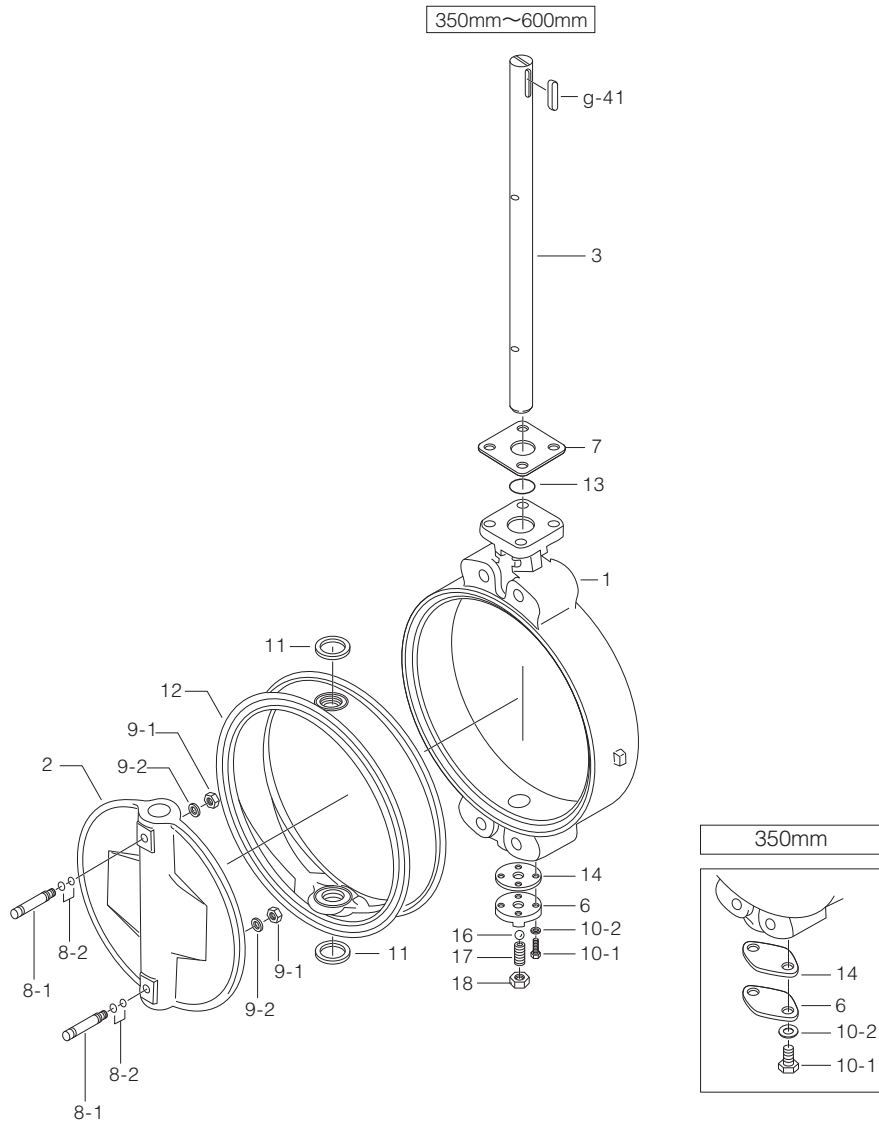

731R Parts list (350mm – 600mm)

No.	Description	Q'ty	Remarks
★ 1	Body	1	
2	Disc	1	
3	Stem	1	
6	Bottom cover	1	
7	Retainer plate	1	
★ 8-1	Taper bolt	2	
★ 8-2	O-ring	4	
★ 9-1	Hexagon nut	2	
★ 9-2	Spring washer	2	
10-1	Hexagon bolt	2	350mm
		4	400mm to 600mm
10-2	Spring washer	2	350mm
		4	400mm to 600mm
★ 11	Secondary seal ring	2	350mm to 600mm assembled in Body
★ 12	Seat ring	1	Vulcanized to body
★ 13	O-ring	1	
★ 14	Gasket	1	
16	Ball	1	400mm to 600mm
17	Hollow bolt	1	400mm to 600mm
18	Lock nut	1	400mm to 600mm
g41	Key	1	

Note) The ★ indicates recommended spare parts. They are supplied as a "Seat ring set".

731R Actuator selection chart

Type	Model	Category	Size (mm / inch)				
			350	400	450	500	600
			14	16	18	20	24
Worm Gear	2U, 2H	Standard	2 U-5	2H *			

* The gear size of 400 and 450 is different from that of 500 and 600.

Butterfly Valve
TRITEC
TT2
334A
344Q
302A/303Q
304A/304Q
304YA
302Y/304Y
304M (HLV)
507V/508V
DTM
846T/847T/847Q
841T/842T
700Z
700G/704G/705G
72WG/72SG/72LG
731P/732P/732Q/752W
731R
700E/700K/700S
704G/722F/720F
227P
907T/908H (MKT)
903L/901C/905C (Bata-check)

731R Pressure – temperature rating

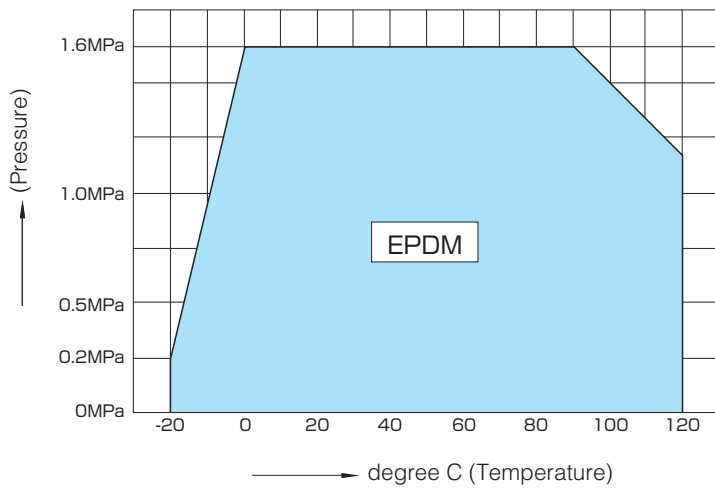

731R

Worm gear type 731R-2U, 2H (350mm to 600mm)

Nominal size		Dimension (mm)										Gear type	Approx. mass (kg)
mm	inch	ϕd	ϕD	L	H ₁	H ₂	H ₃	E	K	F	W		
350	14	337	410	78	276	348	50	90	105	266	280	2U-5	66
400	16	394	467	102	338	383	48	105	110	311	300	2H	98
450	18	441	525	114	368	413	48	105	110	316	350	2H	124
500	20	492	580	127	403	453	56	53	111	328	400	2H	158
600	24	584	682	154	458	528	56	53	111	328	400	2H	222

731R-2U • 2H

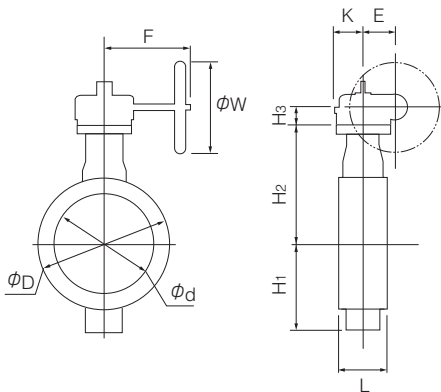

2U/2H Installation direction

2UA/2HA (standard)	2UAR/2HAR
2UB	2UBR
2HB	2HBR

731R Cv value/Pressure loss coefficient

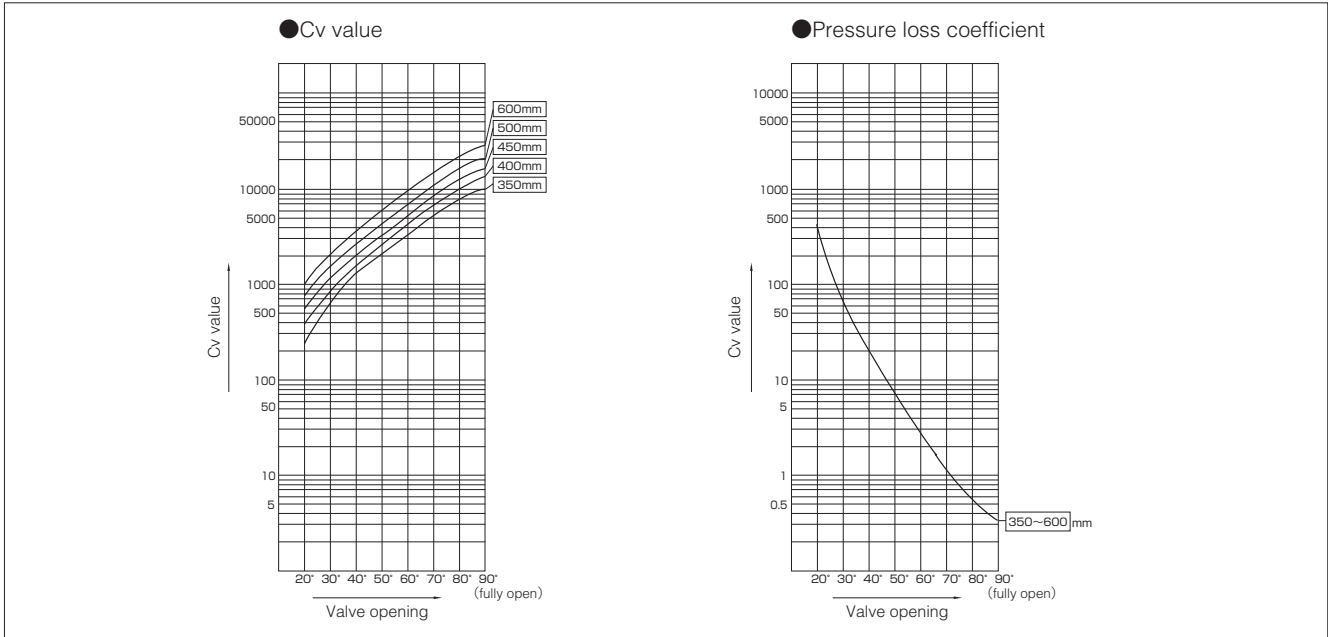

Butterfly Valve

TRITEC

TT2

334A

344Q

302A/303Q

304A/304Q

304YA

302Y/304Y

304M (HLV)

507V/508V

DTM

846T/847T/847Q

841T/842T

700Z

700G/704G/705G

72WG/72SG/72LG

731P/732P/732Q/752W

731R

700E/700K/700S

704G/722F/720F

227P

907T/908H (MKT)

903L/901C/905C (Bata-check)

731R Cv value

Nominal size		Valve opening							
mm	inch	20°	30°	40°	50°	60°	70°	80°	90°
350	14	232	662	1350	2030	3294	5167	7832	9620
400	16	468	964	1648	2724	4529	6815	10553	12700
450	18	583	1202	2068	3448	5692	8384	13116	15500
500	20	758	1555	2656	4379	7214	10845	17100	19800
600	24	1037	2141	3681	6129	10106	14911	22827	27300

731R Pressure loss coefficient

Nominal size		Valve opening							
mm	inch	20°	30°	40°	50°	60°	70°	80°	90°
350	14	531	65	16	7	3	1	0.4	0.3
400	16	227	54	18	7	2	1	0.4	0.3
450	18	239	56	19	7	3	1	0.4	0.3
500	20	218	52	18	7	2	1	0.4	0.3
600	24	247	58	20	7	3	1	1	0.3

731R

731R Flange accommodation

Nominal size		JIS	ASME
mm	inch	16K	Class 150
350	14	D	D
400	16	D	D
450	18	D	D
500	20	D	D
600	24	T	T

D: With flange drilling
T: With flange tapping

731R Applicable pipe list in case of A

Nominal size		SGP	STPY	Sch20	Sch40	Sch10S	Sch20S	Minimum internal diameter of piping (mm)
mm	inch							
350	14	○	○	○	○	—	—	330
400	16	○	○	○	○	—	—	381
450	18	○	○	○	○	—	—	427
500	20	○	○	○	○	—	—	477
600	24	—	○	○	○	—	—	567

731R Applicable pipe list in case of B

Nominal size		SGP	STPY	Sch20	Sch40	Sch10S	Sch20S
mm	inch						
350	14	○	○	○	○	—	—
400	16	○	○	○	○	—	—
450	18	○	○	○	○	—	—
500	20	○	○	○	○	—	—
600	24	—	○	○	○	—	—

Note 1) ○ = Applicable, - = No standard

Note 2) Butterfly valves are inserted into a pipe that has been fitted with the disc fully open. It is still possible to use a pipe or a flange that is less than the minimum inner pipe diameter, with extra adaptation, such as insertion of a spacer between the valve and the flange. For details, please consult our sales office.

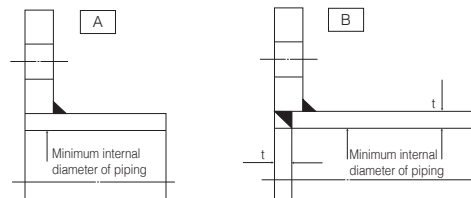

731R Piping bolt and nut sizes

Hexagon bolts and nuts

Nominal size		JIS 16K	
mm	inch	Hexagon bolt and nuts	Setting bolts
350	14	16-M30(P3)×180	—
400	16	16-M30(P3)×215	—
450	18	20-M30(P3)×230	—
500	20	20-M30(P3)×245	—
600	24	20-M36(P3)×285	8-M36(P3)×85

Long bolts and nuts

Nominal size		JIS 16K	
mm	inch	Long bolt and nuts	Setting bolts
350	14	16-M30(P3)×225	—
400	16	16-M30(P3)×260	—
450	18	20-M30(P3)×280	—
500	20	20-M30(P3)×295	—
600	24	20-M36(P3)×340	8-M36(P3)×85

Examples

Setting bolts: 12 - M22 × 185 × 45
 | | | |
 N M L S

Long bolts: 4 - M30 × 95 × 65
 (Hexagon bolts) | | | |
 N M L S

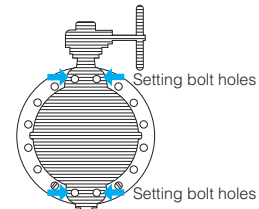
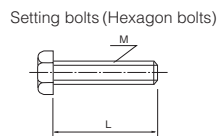
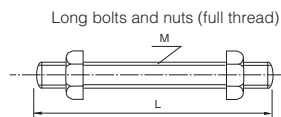

Butterfly Valve
TRITEC
TT2
334A
344Q
302A/303Q
304A/304Q
304YA
302Y/304Y
304M (HLV)
507V/508V
DTM
846T/847T/847Q
841T/842T
700Z
700G/704G/705G
72WG/72SG/72LG
731P/732P/732Q/752W
731R
700E/700K/700S
704G/722F/720F
227P
907T/908H (MKT)
903L/901C/905C (Bata-check)