

700Z

Valve nominal size

40 to 300mm

Max. working pressure MPa

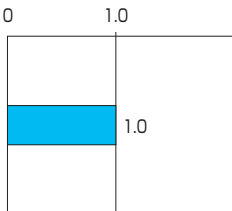

Working temperature range °C

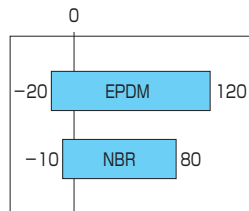

JIS JIS B 2032 Compliant
 (This product conforms to General Specifications for Machinery and Equipment of the Ministry of Land, Infrastructure, Transport and Tourism.)

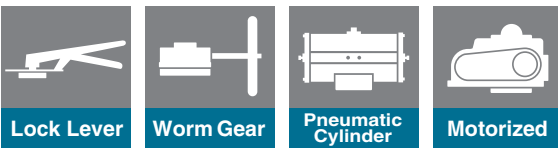

Evolution of Long Sellers Sealing performance and Durability Improved!

- Gears and lever have been integrated with valve body to achieve both functionality and downsizing.
- Resin-aluminum hybrid gearbox improves the strength and durability of valves with anti-condensation performance added.
- High anti-condensation performance of the Z series has been inherited. (Gear valves)
- New lightweight valve disc with optimized seal shape improves the sealing performance and operability of valves.
- Modified rubber seat structure stabilizes the sealing performance of valve seat.
- Strong bearings have been adopted to significantly improve the durability of valve opening/closing. (Automatic valves)
- Special valve body has been developed for automatic valves to improve their strength and durability.

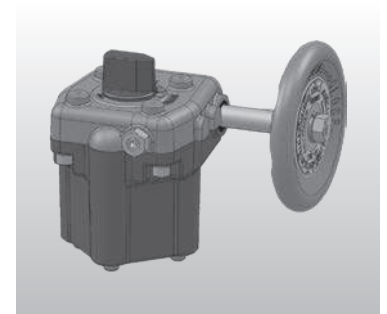

***Note : These valves are different in face-to-face dimensions from the first 700Z (Coating color: Light blue; Munsell 10BG-6/4) developed in 1980 and discontinued in August 2003.**

Standard Specifications

Body type (Connection)	Concentric rubber seated butterfly valve, flangeless (wafer) type	
Valve nominal size	40, 50, 65, 80, 100, 125, 150, 200, 250, 300mm	
Flange accommodation	JIS5K/10K, ASME Class 125/150, DIN PN10, BS4504 PN10, GB/T 9113.1 1MPa	
Face-to-face dimensions	JIS B 2002 ¹⁹⁸⁷ Series 46 (ISO 5752 table5/BS5155/API609)	
Max. working pressure	1.0 MPa	
Allowable seat leakage rate	JIS B 2003 ²⁰¹³ Rate A (Tight shut-off)	
Flow direction	Bi-directional	
Test	Body shell test	1.5 MPa (Hydraulic pressure)
Pressure	Seat leak test	1.1 MPa (Pneumatic pressure)
Working temperature range	EPDM: -20 ~ 120°C (Option: NBR: -10 ~ 80°C)	
Working temperature in continuous use ^{*1}	EPDM: 0 ~ 70°C (Option: NBR: 0 ~ 60°C)	
Standard materials	Body	Aluminum die cast alloy ADC12
	Disc ^{*2}	SCS13 (A351 CF8), SCS14 (A351 CF8M), PPS (40~200mm)
	Stem ^{*2}	SUS420J2 (AISI420)
	Seat ring	EPDM ^{*3,4} (Option: NBR)
Top flange	Lever/Gear type: Valve integrated type, Cylinder/ Electric motor type: In accordance with ISO 5211	
Actuator ^{*5}	Manual, pneumatic, electric	
Pipe flow velocity (limit value)	Up to 3 m/s (Valve fully-open, continuous operation, ambient temp. and fresh water)	
Coating	Urethane coating (Tomoe green)	
Condensation property	No condensation in the upper part of gears at ambient temperature 30°C and humidity 80% with cold water at 5°C ^{*6}	

※1 'Working temperature in continuous use' stands for the temperature continuously kept exceeding on hour.

※2 Materials shown in (): equivalent materials in ASTM/AISI standard.

※3 If the fluid contains even a slight amount of oil, never use an EPDM rubber seat ring. If the fluid contains chlorine, the seat ring may deteriorate early due to combined factors including density and temperature. For details consult our sales office.

※4 In the pipe lines where chemicals containing calcium are supplied, it is recommended to use an EPDM rubber seat ring to protect pipes.

※5 The actuator of the product cannot be replaced.

※6 These values are based on data obtained in a laboratory and may vary if the temperature and humidity distributions in the field are not uniform. Even in an environment having these values, condensation can occur if ambient or water temperature changes suddenly.

Butterfly Valve

TRITEC

TT2

334A

344Q

302A/303Q

304A/304Q

304YA

302Y/304Y

304M

(HLV)

507V/508V

DTM

846T/847T/847Q

841T/842T

700Z

700G/704G/705G

72WG/72SG/72LG

**731P/732P/
732Q/752W**

731R

700E/700K/700S

704G/722F/720F

227P

907T/908H

(MKT)

**903L/901C/
905C (Bata-check)**

700Z Actuator Selection Chart

Type	Model	Category	Size (mm/inch)									
			40	50	65	80	100	125	150	200	250	300
			1 1/2	2	2 1/2	3	4	5	6	8	10	12
Lock lever	1J,1T	Standard	1J-1			1J-2		1T-2				
		Heavy duty										
Worm gear	2F	Standard	2F-G0Z		2F-G00		2F-G01		2F-G02		2F-G03	
		Heavy duty										
Double-action pneumatic	7E	Standard	T35		T85		T200		T380		T750	
		Heavy duty										
Single-action pneumatic	7G,7F 3K,3U	Standard	T85S		T200S		T380S		T750S		TG-12S	
		Heavy duty										
Single phase motor	4I	ON-OFF	4I-00		4I-0		4I-1	4I-2		4I-2.5	4I-3	
		Control										

Note) In case of the single-phase motorized actuator 4I that has the following optional equipment, "Control" specification is applied.

- Micom unit
- Servo unit
- Speed control unit
- Potentiometer

Selection criteria	Standard	Select when none of the following heavy duty items apply.
	Heavy duty	Select when any of the following items apply. ① Gas, powder or high viscosity slurry (crude oil, etc.) ② Control specification (with positioner) ③ Emergency open valve or pipe dead end valve

700Z Pressure-Temperature Rating

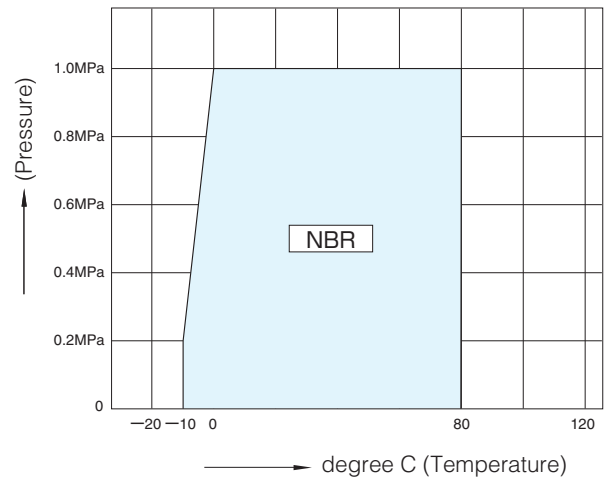
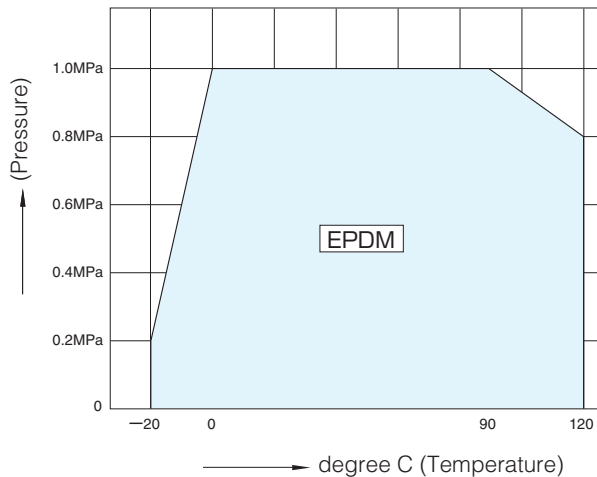

※Prolonged use in high temperature may deteriorate sealing ability or durability.

Lock Lever Type 700Z-1J(40mm to 125m)、1T(150m)

Nominalsize		Dimension (mm)									Approx. Weight (kg)
mm	inch	ϕd	ϕD	L	H ₁	H ₂	H ₃	Q	K	W	
40	1 1/2	45	80	35	47	144	56	72	49	160	0.8
50	2	56	91	43	57	150	56	72	49	160	0.9
65	2 1/2	69	111	46	64	163	56	72	49	160	1.1
80	3	84	125	46	77	151	56	72	49	160	1.4
100	4	104	147	52	94	162	70	72	49	200	1.9
125	5	130	180	56	108	190	70	72	49	200	3.0
150	6	153.5	210	56	125	201	96	88	63	300	5.0

700Z-1J/1T

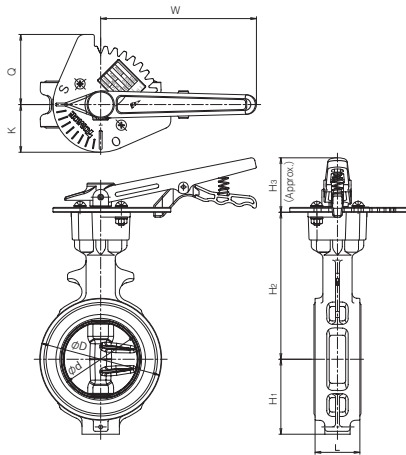

1J Installation direction

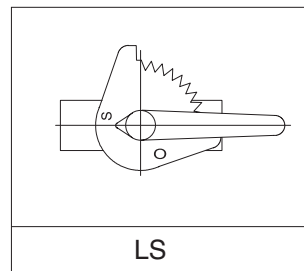

Worm Gear Type 700Z-2F(40mm to 300mm)

Nominalsize		Dimension (mm)									Approx. Weight (kg)
mm	inch	ϕd	ϕD	L	H ₁	H ₂	E	K	F	ϕW	
40	1 1/2	45	80	35	47	160	22.5	26	85	70	0.8
50	2	56	91	43	57	166	22.5	26	85	70	1.0
65	2 1/2	69	111	46	64	179	22.5	26	85	70	1.2
80	3	84	125	46	77	172	28	31	110	70	1.7
100	4	104	147	52	94	183	28	31	110	70	2.2
125	5	130	180	56	108	211	46	42	133	100	3.8
150	6	153.5	210	56	125	222	46	42	133	100	4.7
200	8	199	255	60	167	257	53	40	162	125	7.2
250	10	253	322	68	186	316	71	54	206	200	13
300	12	302	375	78	216	348	71	54	206	200	18

700Z-2F

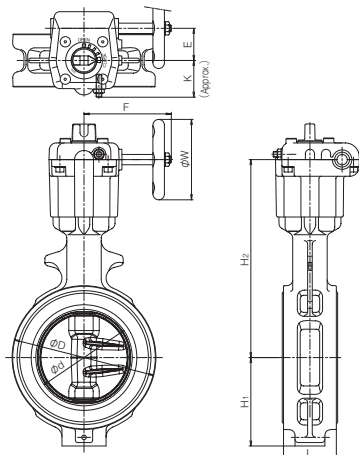

2F Installation direction

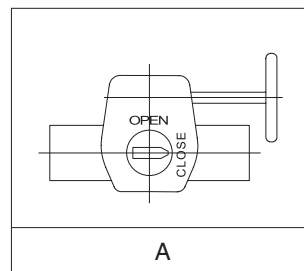

Butterfly Valve
TRITEC
TT2
334A
344Q
302A/303Q
304A/304Q
304YA
302Y/304Y
304M (HLV)
507V/508V
DTM
846T/847T/847Q
841T/842T
700Z
700G/704G/705G
72WG/72SG/72LG
731P/732P/732Q/752W
731R
700E/700K/700S
704G/722F/720F
227P
907T/908H (MKT)
903L/901C/905C (Bata-check)

700Z

Double-acting Pneumatic Cylinder Type 700Z-7E (40mm to 300mm)

Standard

Nominal size		Dimension (mm)												Cylinder type	Approx. Weight (kg)
mm	inch	ϕd	ϕD	L	H ₁	H ₂	H ₃	A	P	f ₁	f ₂	f ₃	t ₁		
40	1 1/2	45	80	35	47	132	125	228	116	57	29	35	1	T35	2.6
50	2	56	91	43	57	138	125	228	116	57	29	35	1	T35	2.7
65	2 1/2	69	111	46	64	151	125	228	116	57	29	35	1	T35	2.9
80	3	84	125	46	77	156	125	228	116	57	29	35	1	T35	3.4
100	4	104	147	52	94	167	168	276	142	75	47	51	1	T85	6.8
125	5	130	180	56	108	191	168	276	142	75	47	51	1.5	T85	8.1
150	6	153.5	210	56	125	202	203	346	176	79	57	51	1.5	T200	12.3
200	8	199	255	60	167	227	203	346	176	79	57	51	1.5	T200	14.5
250	10	253	322	68	186	280	231	423	214	91	69	63	1.5	T380	25.5
300	12	302	375	78	216	312	269	546	270	118	85	70	1.5	T750	39.6

Heavy Duty

Nominal size		Dimension (mm)												Cylinder type	Approx. Weight (kg)
mm	inch	ϕd	ϕD	L	H ₁	H ₂	H ₃	A	P	f ₁	f ₂	f ₃	t ₁		
40	1 1/2	45	80	35	47	132	125	228	116	57	29	35	1	T35	2.6
50	2	56	91	43	57	138	125	228	116	57	29	35	1	T35	2.7
65	2 1/2	69	111	46	64	151	125	228	116	57	29	35	1	T35	2.9
80	3	84	125	46	77	156	168	276	142	75	47	51	1	T85	6.4
100	4	104	147	52	94	167	168	276	142	75	47	51	1	T85	6.8
125	5	130	180	56	108	191	203	346	176	79	57	51	1.5	T200	11.4
150	6	153.5	210	56	125	202	203	346	176	79	57	51	1.5	T200	12.3
200	8	199	255	60	167	227	231	423	214	91	69	63	1.5	T380	20.7
250	10	253	322	68	186	280	231	423	214	91	69	63	1.5	T380	25.5
300	12	302	375	78	216	312	269	546	270	118	85	70	1.5	T750	39.6

700Z-7E

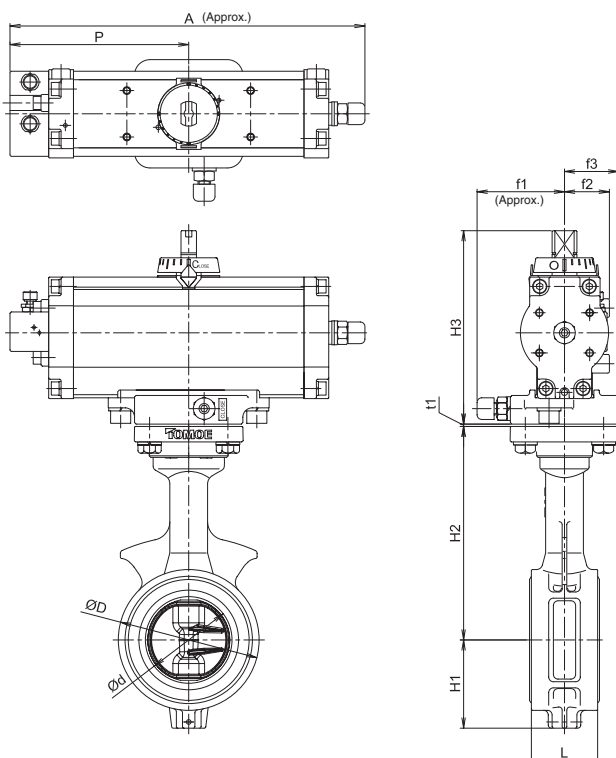

7E Installation Direction

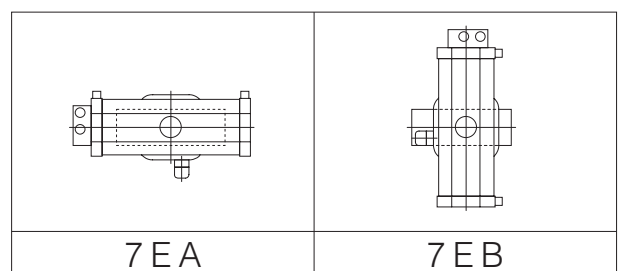

Single-acting Pneumatic Cylinder Type 700Z-7G(40mm to 200mm)/700Z-7F(40mm to 200mm)

■ Standard

Nominal size		Dimension (mm)												Cylinder type	Approx. Weight (kg)
mm	inch	ϕd	ϕD	L	H ₁	H ₂	H ₃	A	P	f ₁	f ₂	f ₃	t ₁		
40	1 1/2	45	80	35	47	132	168	364	183	75	47	51	1	T85S	7.2
50	2	56	91	43	57	138	168	364	183	75	47	51	1	T85S	7.3
65	2 1/2	69	111	46	64	151	168	364	183	75	47	51	1	T85S	7.5
80	3	84	125	46	77	156	203	449	226	79	57	51	1	T200S	12.5
100	4	104	147	52	94	167	203	449	226	79	57	51	1	T200S	12.9
125	5	130	180	56	108	191	231	550	276	91	69	63	1.5	T380S	22.5
150	6	153.5	210	56	125	202	231	550	276	91	69	63	1.5	T380S	23.4
200	8	199	255	60	167	227	269	723	360	118	85	70	1.5	T750S	39.2
250	10	253	322	68	186	280	269	723	360	118	85	70	1.5	T750S	43.8

■ Heavy Duty

Nominal size		Dimension (mm)												Cylinder type	Approx. Weight (kg)
mm	inch	ϕd	ϕD	L	H ₁	H ₂	H ₃	A	P	f ₁	f ₂	f ₃	t ₁		
40	1 1/2	45	80	35	47	132	168	364	183	75	47	51	1	T85S	7.2
50	2	56	91	43	57	138	168	364	183	75	47	51	1	T85S	7.3
65	2 1/2	69	111	46	64	151	203	449	226	79	57	51	1	T200S	12.0
80	3	84	125	46	77	156	203	449	226	79	57	51	1	T200S	12.5
100	4	104	147	52	94	167	231	550	276	91	69	63	1	T380S	21.2
125	5	130	180	56	108	191	231	550	276	91	69	63	1.5	T380S	22.5
150	6	153.5	210	56	125	202	269	723	360	118	85	70	1.5	T750S	37.0
200	8	199	255	60	167	227	269	723	360	118	85	70	1.5	T750S	39.2

■ 700Z-7G/7F

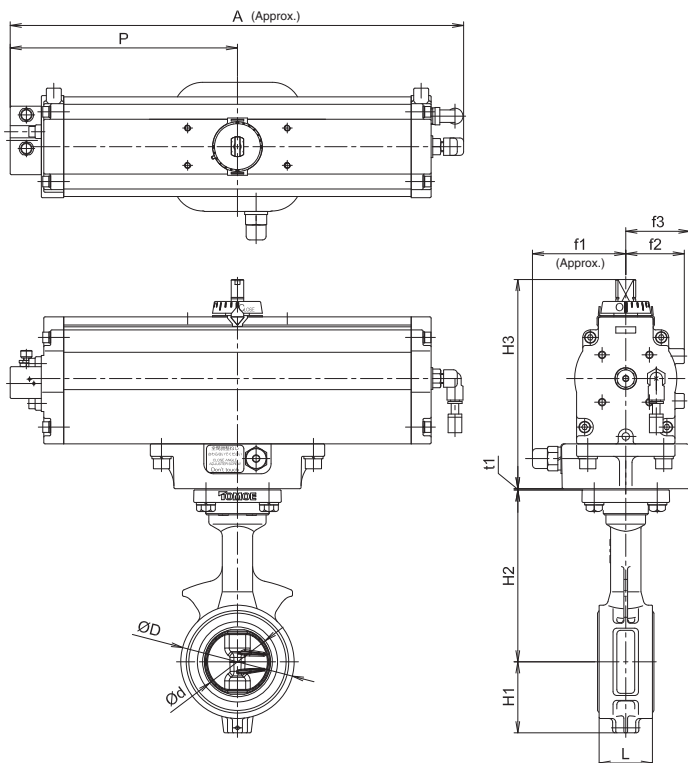

■ 7G/7F Installation Direction

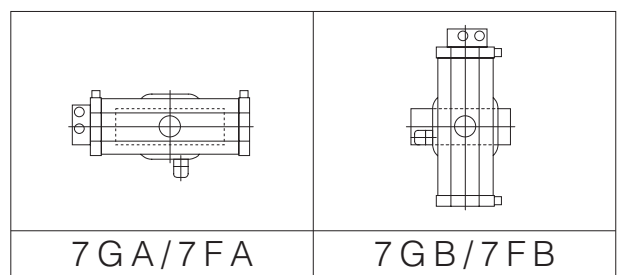

Butterfly Valve
TRITEC
TT2
334A
344Q
302A/303Q
304A/304Q
304YA
302Y/304Y
304M (HLV)
507V/508V
DTM
846T/847T/847Q
841T/842T
700Z
700G/704G/705G
72WG/72SG/72LG
731P/732P/732Q/752W
731R
700E/700K/700S
704G/722F/720F
227P
907T/908H (MKT)
903L/901C/905C (Bata-check)

700Z

Single-acting Pneumatic Cylinder Type 700Z-3U (250mm to 300mm)

Standard/Heavy Duty

Nominal size		Dimension (mm)													Cylinder type	Approx. Weight (kg)
mm	inch	ϕd	ϕD	L	H ₁	H ₂	H ₃	H ₄	A	P	B	f ₁	f ₂	t ₁		
250	10	253	322	68	186	280	307	4	1080	720	60	206	94	1.5	TG-12S	110.8
300	12	302	375	78	216	312	307	4	1080	720	60	206	94	1.5	TG-12S	115.3

700Z-3U

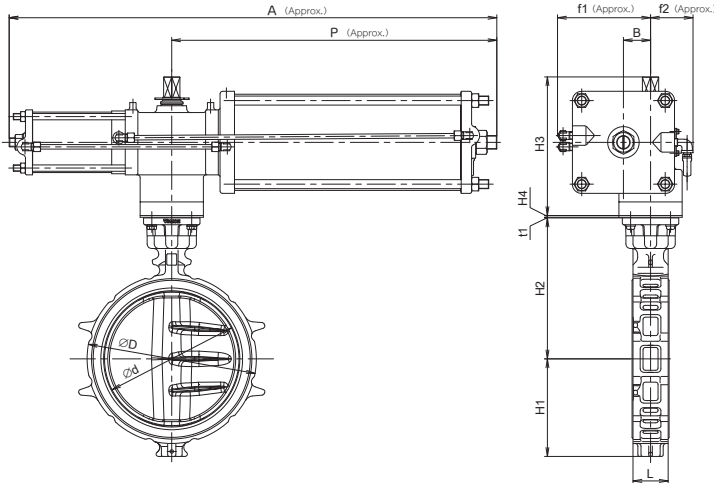

3U Installation Direction

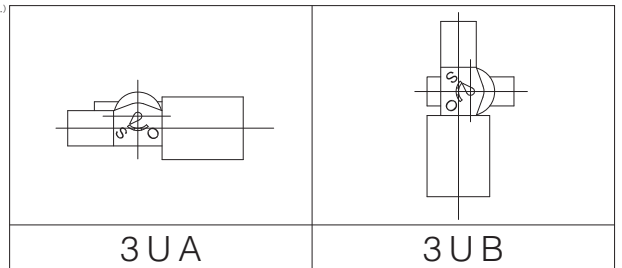

Single-acting Pneumatic Cylinder Type 700Z-3K (250mm to 300mm)

Standard/Heavy Duty

Nominal size		Dimension (mm)													Cylinder type	Approx. Weight (kg)
mm	inch	ϕd	ϕD	L	H ₁	H ₂	H ₃	H ₄	A	P	B	f ₁	f ₂	t ₁		
250	10	253	322	68	186	280	307	4	1080	720	60	206	94	1.5	TG-12S	110.8
300	12	302	375	78	216	312	307	4	1080	720	60	206	94	1.5	TG-12S	115.3

700Z-3K

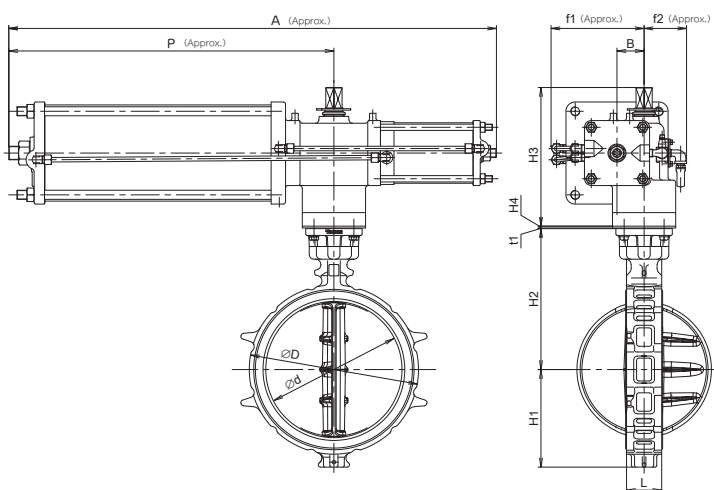

3K Installation Direction

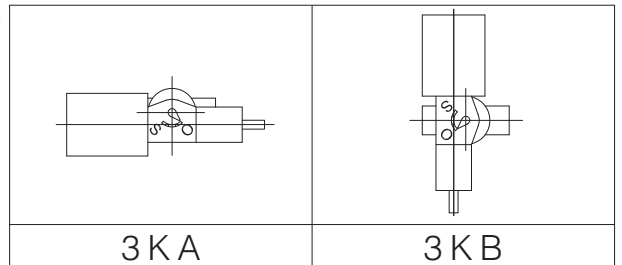

Single Phase Electric Motor Type 700Z-4 I (40mm to 300mm)

■ ON-OFF

Nominal size		Dimension (mm)																	Motor type	Approx. Weight (kg)
mm	inch	φd	φD	L	H ₁	H ₂	H ₃	H ₄	H ₅	H ₆	A ₁	A ₂	E	F	K	φW	t ₁			
40	1 1/2	45	80	35	47	132	121	—	100	57	84	77	39	58	45	80	1	4I-00	3.0	
50	2	56	91	43	57	138	121	—	100	57	84	77	39	58	45	80	1	4I-00	3.1	
65	2 1/2	69	111	46	64	151	121	—	100	57	84	77	39	58	45	80	1	4I-00	3.3	
80	3	84	125	46	77	156	150	—	100	43	100	102	43	85	54	80	1	4I-0	6.1	
100	4	104	147	52	94	167	150	—	100	43	100	102	43	85	54	80	1	4I-0	6.5	
125	5	130	180	56	108	191	165	14	100	61	138	114	12	126	65	70	1.5	4I-1	10.3	
150	6	153.5	210	56	125	202	198	—	100	80	167	143	14	154	85	100	1.5	4I-2	16.2	
200	8	199	255	60	167	227	198	—	100	80	167	143	14	154	85	100	1.5	4I-2	18.4	
250	10	253	322	68	186	280	201	20	100	80	167	143	14	154	85	100	1.5	4I-2.5	26.3	
300	12	302	375	78	216	312	230	4	100	98	223	165	23	246	136	200	1.5	4I-3	41.0	

■ 700Z-4 I (ON-OFF)

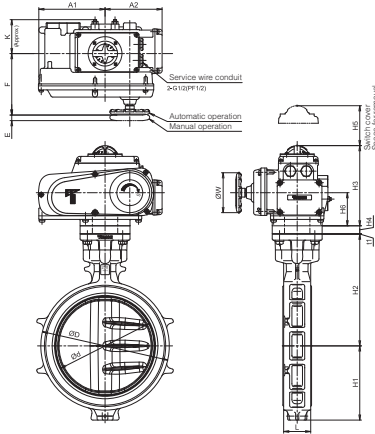

■ 4 I Installation Direction

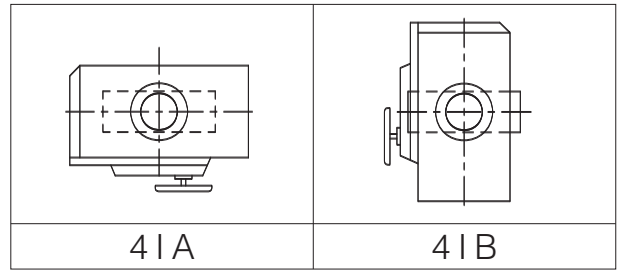

■ Control

Nominal size		Dimension (mm)																	Motor type	Approx. Weight (kg)
mm	inch	φd	φD	L	H ₁	H ₂	H ₃	H ₄	H ₅	H ₆	A ₁	A ₂	E	F	K	φW	t ₁			
40	1 1/2	45	80	35	47	132	176	—	100	43	100	102	43	85	54	80	1	4I-0	5.3	
50	2	56	91	43	57	138	176	—	100	43	100	102	43	85	54	80	1	4I-0	5.4	
65	2 1/2	69	111	46	64	151	176	—	100	43	100	102	43	85	54	80	1	4I-0	5.6	
80	3	84	125	46	77	156	176	—	100	43	100	102	43	85	54	80	1	4I-0	6.1	
100	4	104	147	52	94	167	176	—	100	43	100	102	43	85	54	80	1	4I-0	6.5	
125	5	130	180	56	108	191	191	14	100	61	138	114	12	126	65	70	1	4I-1	10.3	
150	6	153.5	210	56	125	202	224	—	100	80	167	143	14	154	85	100	1	4I-2	16.2	
200	8	199	255	60	167	227	224	—	100	80	167	143	14	154	85	100	1	4I-2.5	20.0	
250	10	253	322	68	186	280	227	20	100	80	167	143	14	154	85	100	1.5	4I-2.5	26.3	
300	12	302	375	78	216	312	255	4	100	98	223	165	23	246	136	200	1.5	4I-3	41.0	

■ 700Z-4 I (Control)

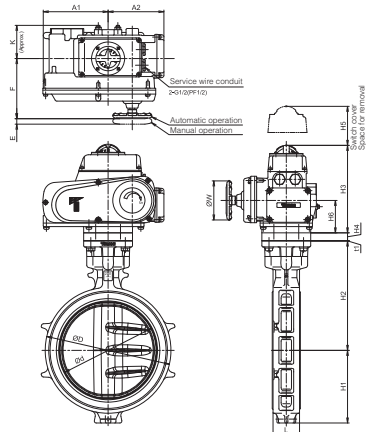

■ 4 I Installation Direction

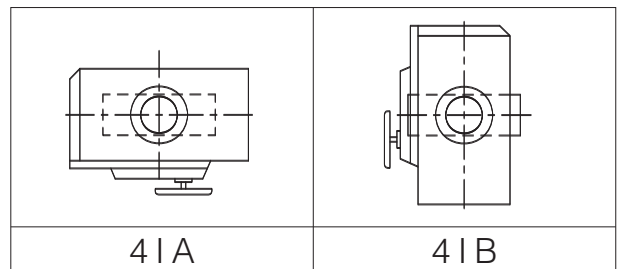

Butterfly Valve

TRITEC

TT2

334A

344Q

302A/303Q

304A/304Q

304YA

302Y/304Y

304M

(HLV)

507V/508V

DTM

846T/847T/847Q

841T/842T

700Z

700G/704G/705G

72WG/72SG/72LG

731P/732P/

732Q/752W

731R

700E/700K/700S

704G/722F/720F

227P

907T/908H

(MKT)

903L/901C/

905C(Bata-check)

700Z Cv value / pressure loss coefficient

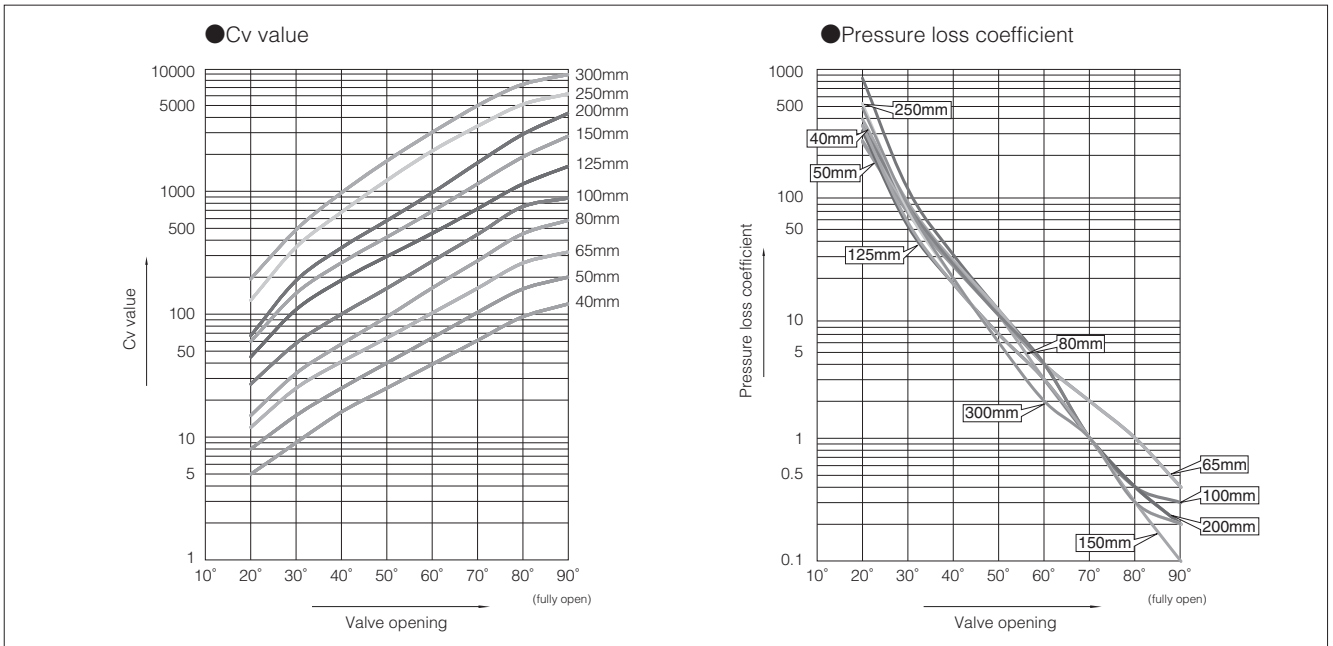

700Z Cv value

Nominal size		Valve opening							
mm	inch	20°	30°	40°	50°	60°	70°	80°	90°
40	1 1/2	5	9	16	25	39	61	95	121
50	2	8	15	25	40	64	103	160	200
65	2 1/2	12	25	41	64	102	162	260	320
80	3	15	33	57	95	163	271	450	580
100	4	27	58	100	162	269	444	749	880
125	5	45	109	189	295	453	719	1144	1590
150	6	60	148	262	423	685	1147	1897	2800
200	8	67	188	347	576	969	1698	2902	4300
250	10	130	351	675	1225	2125	3375	5091	6200
300	12	194	487	972	1764	3011	4966	7412	8900

700Z Pressure loss coefficient

Nominal size		Valve opening							
mm	inch	20°	30°	40°	50°	60°	70°	80°	90°
40	1 1/2	264	72	26	10	4	2	1	0.4
50	2	257	68	25	10	4	2	1	0.4
65	2 1/2	310	75	28	11	4	2	1	0.4
80	3	394	83	27	10	3	1	0.4	0.2
100	4	350	78	26	10	4	1	0.4	0.3
125	5	316	53	18	7	3	1	0.4	0.2
150	6	348	57	18	7	3	1	0.3	0.1
200	8	849	106	31	11	4	1	0.4	0.2
250	10	528	72	20	6	2	1	0.3	0.2
300	12	488	78	20	6	2	1	0.3	0.2

700Z Applicable pipe list in case of **A**, **B**

Nominal size		SGP	Sch20	Sch40	VP (TS flange)	Sch10S	Sch20S	Minimum internal diameter of piping (mm)
mm	inch							
40	1 1/2	○	—	○	○	○	○	29
50	2	○	○	○	○	○	○	38
65	2 1/2	○	○	○	○	○	○	54
80	3	○	○	○	○	○	○	72
100	4	○	○	○	○	○	○	92
125	5	○	○	○	○	○	○	119
150	6	○	○	○	○	○	○	145
200	8	○	○	○	○	○	○	194
250	10	○	○	○	○	○	○	247
300	12	○	○	○	○	○	○	295

Remark 1: The symbols above mean the following.

○: Piping possible —: Not standardized

Remark 2: Butterfly valves are inserted into a pipe that was fitted with the disc when fully open.

In cases where you are using a pipe or flange that is less than the minimum inner pipe diameter, use is still possible if means are taken such as inserting a spacer between the valve and flange. For details, please consult us.

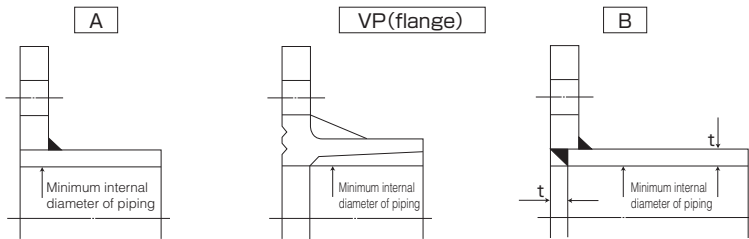

Butterfly Valve
TRITEC
TT2
334A
344Q
302A/303Q
304A/304Q
304YA
302Y/304Y
304M (HLV)
507V/508V
DTM
846T/847T/847Q
841T/842T
700Z
700G/704G/705G
72WG/72SG/72LG
731P/732P/732Q/752W
731R
700E/700K/700S
704G/722F/720F
227P
907T/908H (MKT)
903L/901C/905C (Bata-check)

700Z Piping bolt and nut sizes

Hexagon bolt & nut

Nominal size		JIS 5K	JIS 10K
mm	inch	Hexagon bolts and nuts	Hexagon bolts and nuts
40	1 1/2	4-M12× 75×30	4-M16× 90×38
50	2	4-M12× 90×30	4-M16×100×38
65	2 1/2	4-M12× 90×30	4-M16×105×38
80	3	4-M16× 95×38	8-M16×105×38
100	4	8-M16×105×38	8-M16×110×38
125	5	8-M16×110×38	8-M20×125×46
150	6	8-M16×115×38	8-M20×130×52
200	8	8-M20×130×52	12-M20×130×52
250	10	12-M20×140×52	12-M22×150×60
300	12	12-M20×150×52	16-M22×160×60

Long bolt & nut

Nominal size		JIS 5K	JIS 10K	ASME Class 125/150
mm	inch	Long bolts and nuts	Long bolts and nuts	Long bolts and nuts
40	1 1/2	4-M12× 95×25	4-M16×110×25	4-U1/2 ×110×32
50	2	4-M12×105×25	4-M16×120×30	4-U5/8 ×140×38
65	2 1/2	4-M12×110×25	4-M16×125×30	4-U5/8 ×140×38
80	3	4-M16×120×30	8-M16×125×30	4-U5/8 ×140×38
100	4	8-M16×130×30	8-M16×130×30	8-U5/8 ×150×38
125	5	8-M16×130×30	8-M20×150×40	8-U3/4 ×160×51
150	6	8-M16×140×35	8-M20×155×40	8-U3/4 ×165×51
200	8	8-M20×155×40	12-M20×155×40	8-U3/4 ×175×51
250	10	12-M20×165×40	12-M22×175×45	12-U7/8 ×195×58
300	12	12-M20×175×40	16-M22×185×45	12-U7/8 ×205×58

Remark: Please use a hexagon nut with 80% threading. (For ASME, use heavy nut.)

Example

Long bolts : 12 - M22 × 185 × 45 Hexagon bolts : 12 - M22 × 60 × 50

N
M
L
S
N
M
L
S

