

700G Wafer

704G Full lugged

705G Semi lugged

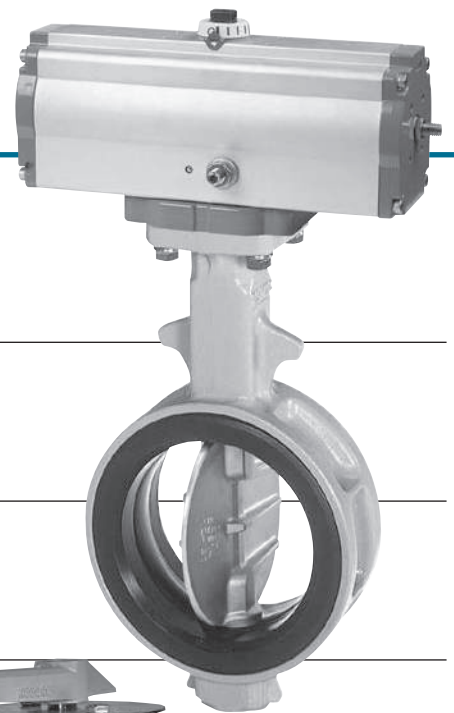

Features and Benefits

Rib disc

The 316 stainless steel (JIS SCS14) rib disc comes standard from 50mm to 300mm. Thin profile disc reinforced by ribs (patent pending) provides larger Cv compared to our conventional design. It also reduces weight while maintaining mechanical strength. A flat face disc is also available on request.



Patented cosine curve seat ring

The cosine curve seat ring reduces valve operating torque substantially and allows the torque to be adjusted according to the working pressure.

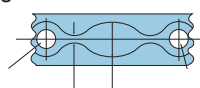

Much longer life with spherical design

Similar to a spherical body rotating inside a spherical area, the operation of the disc is smooth and unhindered. Torque is reduced and the valve life is lengthened by 300%.

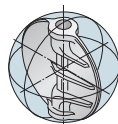

Self-aligning stem seal through backup ring

The stem seal is the primary and secondary seal system. The backup ring functions as the self-aligning stem seal.

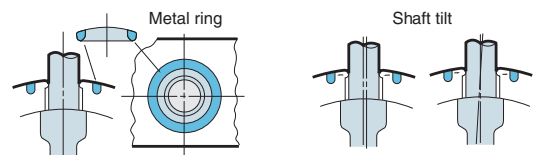

Long bonnet

The long neck shape allows insulation of up to 50mm after the valve is installed. 701G: Nylon coated body is also available (50 to 300mm).

Please contact us for more information.

Two aligning methods (350 to 600mm)

Two valve models are available: the casted hole type (700G) and the tapped and drilled hole type (705G). They accommodate all the applicable flange standards.

Butterfly Valve
TRITEC
TT2
334A
344Q
302A/303Q
304A/304Q
304YA
302Y/304Y
304M (HLV)
507V/508V
DTM
846T/847T/847Q
841T/842T
700Z
700G/704G/705G
72WG/72SG/72LG
731P/732P/732Q/752W
731R
700E/700K/700S
704G/722F/720F
227P
907T/908H (MKT)
903L/901C/905C (Bata-check)

Discs and seats come in various materials to meet a wide range of needs. These are the ultimate general purpose valves and they provide excellent cost performance.

General Description

Handling, durability and longevity are the basic aspects by which valve performance can be improved. TOMOE have now developed the 700G series, a superior, pressure-proof, general purpose valve, with the addition of a wide range of features to offer improved performance and better cost efficiency.

The 700G series is designed to satisfy many international flange standards for use worldwide.

Structure

The body is available in various designs such as wafer, semi-lugged and full-lugged, with various materials such as ductile iron, carbon steel, etc. The disc is also available with high-grade stainless steel, type 316, nylon coating, aluminium, bronze or PPS. The patented cosine-curve structure is adopted for the seat ring. The 700G series is superior to conventional models in all respects.

Standard Specifications

Model	700G (Wafer)			704G (Fully lugged)		705G (Semi lugged)	
Valve nominal size	40 to 300mm	350 to 550mm	600mm	50 to 300mm	350 to 600mm	40 to 300mm	350 to 600mm
Flange accommodation	JIS 5K/10K, ASME Class 125/150, DIN PN10/PN16, BS 4504 PN10/PN16, BS 10' E'	JIS 5K/10K	JIS 5K/10K, ASME Class 125/150, DIN PN10, BS4504 PN10	JIS 5K/10K, ASME Class 125/150, DIN PN10/PN16, BS4504 PN10/PN16, BS 10' E'	JIS 5K/10K, ASME Class 125/150, DIN PN10, BS4504 PN10	JIS 5K/10K, ASME Class 125/150, DIN PN10/PN16, BS4504 PN10/PN16, BS10' E'	JIS 5K/10K, ASME Class 125/150, DIN PN10, BS4504 PN10 550mm:JIS 5K/10K only
Face-to-face dimensions	700G JIS B 2002 46 series/ISO 5752 wafer butterfly valve(short) 550mm: JIS B 2002 44series						
Max. working pressure	1.0 MPa						
Seat leakage	Tight-shutoff						
Flow direction	One way (Flow direction marked on body)						
Body shell test (hydraulic)	1.5MPa(hydraulic) JIS5K: 0.75MPa						
Seat leak test (pneumatic) ※1	1.1MPa(40 to 300mm: pneumatic 350 to 600mm: hydraulic) JIS5K: 0.55MPa						
Working temperature range ※2,※3	NBR : -10 to 80 degrees C, *EPDM : -20 to 120 degrees C						
Working temperature in continuous use ※4	NBR : 0 to 60 degrees C, *EPDM : 0 to 70 degrees C						
Standard materials	Body ※5	Ductile iron, JIS FCD450	Cast iron, JIS FC 250	Ductile iron, JIS FCD450		Ductile iron, JIS FCD 450	Cast iron, JIS FC250, Ductile iron, JIS FCD450
	Disc	316 stainless steel, JIS SCS14 ※6	304 stainless steel, JIS SCS13 316 stainless steel, JIS SCS14	316 stainless steel, JIS SCS14 ※6	304 stainless steel, JIS SCS 13, 316 stainless steel, JIS SCS14	316 stainless steel, JIS SCS 14 ※6	304 stainless steel, JIS SCS 13, 316 stainless steel, JIS SCS 14
		PPS (40 to 200mm) Aluminium bronze JIS CAC702 (50 to 600mm)	Aluminium bronze JIS CAC702	PPS (50 to 200mm) Aluminium bronze JIS CAC702 (50 to 600mm)	Aluminium bronze JIS CAC702	PPS (40 to 200mm) Aluminium bronze JIS CAC702 (50 to 600mm)	Aluminium bronze JIS CAC702
	Ductile iron, JIS FCD 450	Ductile iron, JIS FCD 450		Ductile iron, JIS FCD 450 with hard chrome plating	Ductile iron, JIS FCD 450		
	Stem	SUS420J2 / SUS329J1 as an option (550mm: SUS403)					
Seat ring ※7	NBR, *EPDM ※7						
Top flange	ISO5211/1						
Condensation prevention structure	Optional (Condensation prevention resin column)						
Piping flange gasket	Not required						
Coating ※8	40 to 300mm : Epoxy primer(Munsell N7)			350 to 600mm : Lacquer primer (Munsell N7)			

※1 16bar finish is also available subject to working conditions.

※2 Working temperature range varies depending on combination of disc materials and seating. Please consult us.

※3 Please consult us when using NBR and EPDM seating continuously above 60 degrees C and 70 degrees C respectively.

※4 "Working temperature in continuous use" stands for the temperature continuously kept exceeding one hour.

※5 Cast steel body or stainless steel body is also available.

※6 Rib disc: standard. Flat face disc: optional.

※7 Heat resistant EPDM (to 150 degrees C), FKM, SEP, CR and white-NBR seats are also available. See below table.

※8 Polyester powder backed finish (V-Pet #4000) for 700G size 40 to 300mm. Epoxy resin coating for 705G size 50 to 300mm.

※9 Export license by Japanese Ministry is required up to 100mm with FKM seating. Please consult us the detail.

* Never use an EPDM rubber seat ring if the valve is being used for oil or for a fluid containing even a slight amount of oil.

Seat ring material table

Material	Standard		On request						
	EPDM	NBR	Food Grade EPDM	Heat resistant EPDM	HI-NBR	W-NBR	FKM	CR	SEP
Working temperature range (degrees C)	-20~120	-10~80	-20~120	-10~150	-5~80	-10~70	-10~60	-10~80	-10~60
Working temperature in continuous use (degrees C)	0~70	0~60	0~70	0~130	0~60	0~60	0~50	0~60	0~50
Max. working pressure (MPa)	1.0	1.0	1.0	0.5	1.0	0.5	0.5	1.0	0.5

700G Expanded view of components

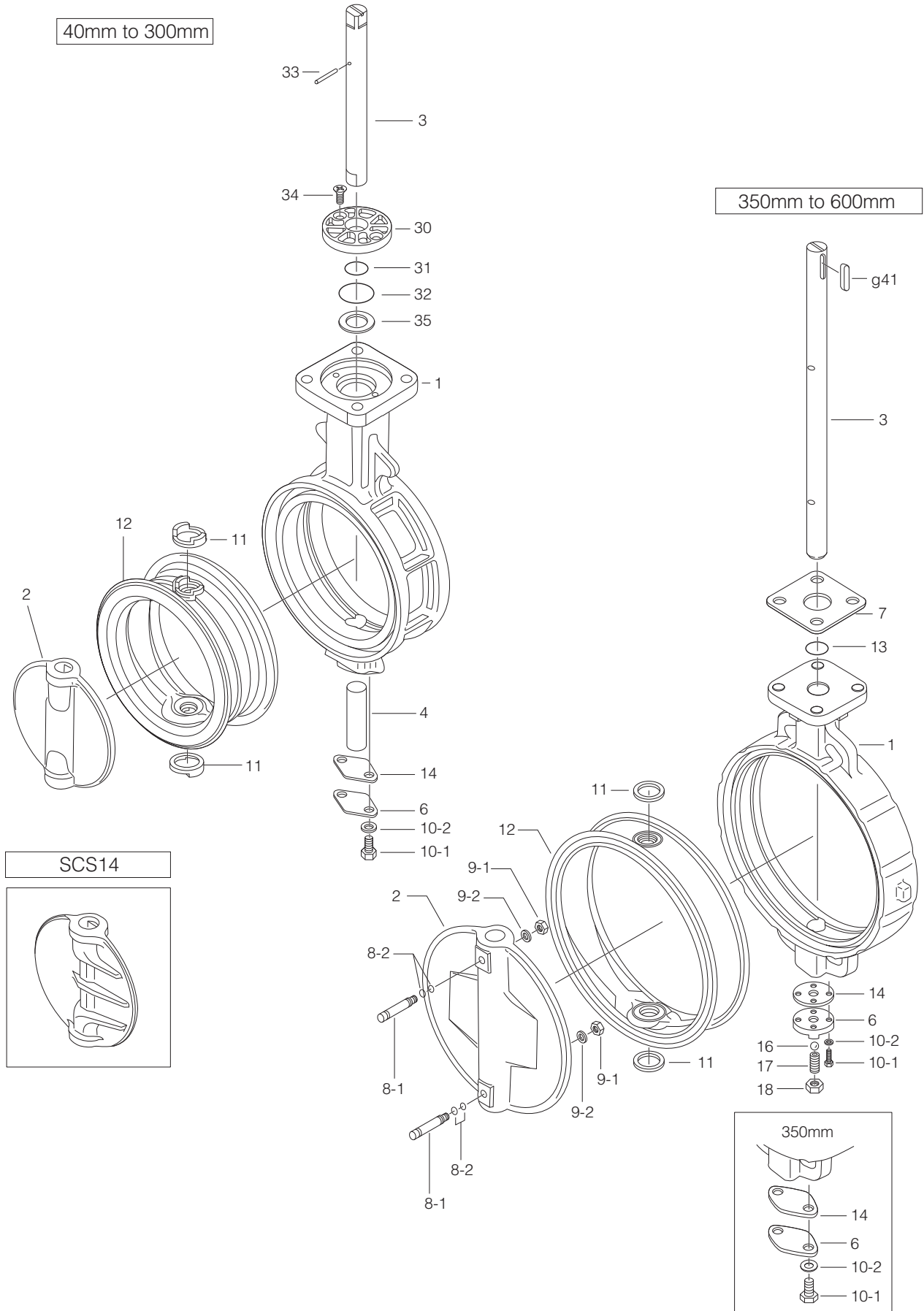

700G Parts list

■ 700G Parts list (40mm to 300mm)

No.	Description	Q'ty	Remarks
1	Body	1	
2	Disc	1	
3	Upper stem	1	
4	Lower stem	1	See Remark 2.
6	Bottom cover	1	
10-1	Hexagon bolt	2	
10-2	Spring washer	2	
★ 11	Secondary ring	2	Only 50mm to 300mm
★ 12	Seat ring	1	
★ 14	Gasket	1	
★ 30	Bushing	1	
★ 31	O-ring	1	
★ 32	O-ring	1	
33	Spring pin	1	
34	Machine screw	2	
35	Plate	1	

■ 700G Parts list (350mm to 600mm)

No.	Description	Q'ty	Remarks
1	Body	1	
2	Disc	1	
3	Stem	1	
6	Bottom cover	1	
7	Retainer plate	1	
★ 8-1	Taper bolt	2	
★ 8-2	O-ring	4	
★ 9-1	Hexagon nut	2	
★ 9-2	Spring washer	2	
10-1	Hexagon bolt	2	350mm
		4	400mm to 600mm
10-2	Spring washer	2	350mm
		4	400mm to 600mm
★ 11	Secondary ring	2	350mm
11	Secondary ring	2	400mm to 600mm
★ 12	Seat ring	1	
★ 13	O-ring	1	
★ 14	Gasket	1	
16	Ball	1	Only 400mm to 600mm
17	Hollow bolt	1	Only 400mm to 600mm
18	Lock nut	1	Only 400mm to 600mm
g41	Key	1	

Remark 1: The ★ indicates recommended spare parts. They are supplied as "Seat ring set".

Remark 2: When the disc material is PPS, the lower stem length of types 50mm to 100mm is different from standard.

Butterfly Valve
TRITEC
TT2
334A
344Q
302A/303Q
304A/304Q
304YA
302Y/304Y
304M (HLV)
507V/508V
DTM
846T/847T/847Q
841T/842T
700Z
700G/704G/705G
72WG/72SG/72LG
731P/732P/732Q/752W
731R
700E/700K/700S
704G/722F/720F
227P
907T/908H (MKT)
903L/901C/905C (Bata-check)

704G Expanded View of Components

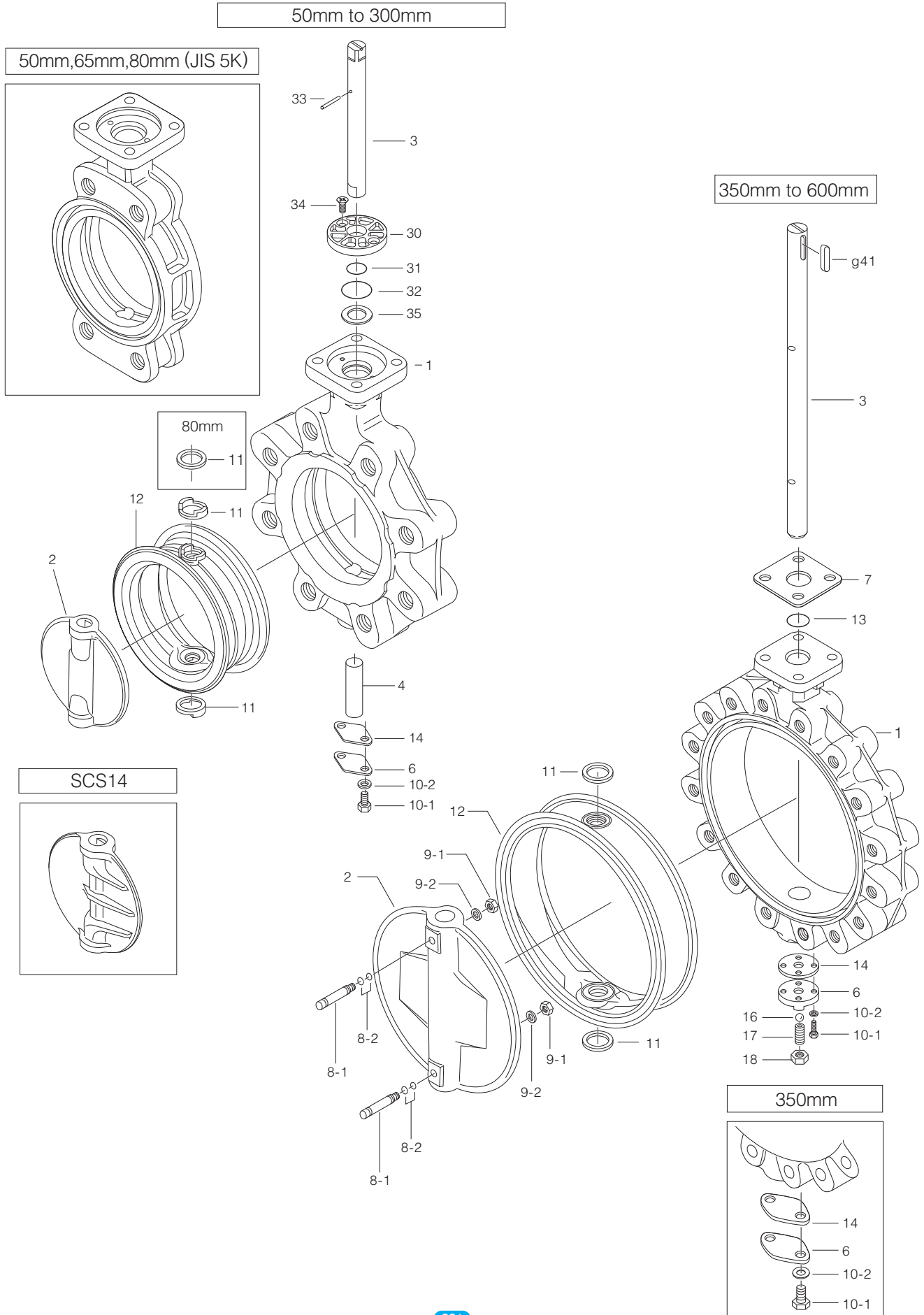

704G Parts list

■ 704G Parts list (50mm to 300mm)

No.	Description	Q'ty	Remarks
1	Body	1	
2	Disc	1	
3	Upper stem	1	
4	Lower stem	1	See Remark 2.
6	Bottom cover	1	
10-1	Hexagon bolt	2	
10-2	Spring washer	2	
★ 11	Secondary ring	2	
★ 12	Seat ring	1	
★ 14	Gasket	1	
★ 30	Bushing	1	
★ 31	O-ring	1	
★ 32	O-ring	1	
33	Spring pin	1	
34	Machine screw	2	
35	Plate	1	

■ 704G Parts list (350mm to 600mm)

No.	Description	Q'ty	Remarks
1	Body	1	
2	Disc	1	
3	Stem	1	
6	Bottom cover	1	
7	Retainer plate	1	
★ 8-1	Taper bolt	2	
★ 8-2	O-ring	4	
★ 9-1	Hexagon nut	2	
★ 9-2	Spring washer	2	
10-1	Hexagon bolt	2	350mm
		4	400mm to 600mm
10-2	Spring washer	2	350mm
		4	400mm to 600mm
★ 11	Secondary ring	2	350mm
11	Secondary ring	2	400mm to 600mm
★ 12	Seat ring	1	
★ 13	O-ring	1	
★ 14	Gasket	1	
16	Ball	1	Only 400mm to 600mm
17	Hollow bolt	1	Only 400mm to 600mm
18	Lock nut	1	Only 400mm to 600mm
g41	Key	1	

Remark 1: The ★ indicates recommended spare parts. They are supplied as "Seat ring set" with a small hexagonal spanner to remove hollow bolt.

Remark 2: When the disc material is PPS, the lower stem length of types 50mm to 100mm is different from standard.

Butterfly Valve
TRITEC
TT2
334A
344Q
302A/303Q
304A/304Q
304YA
302Y/304Y
304M (HLV)
507V/508V
DTM
846T/847T/847Q
841T/842T
700Z
700G/704G/705G
72WG/72SG/72LG
731P/732P/732Q/752W
731R
700E/700K/700S
704G/722F/720F
227P
907T/908H (MKT)
903L/901C/905C (Bata-check)

705G Expanded view of components

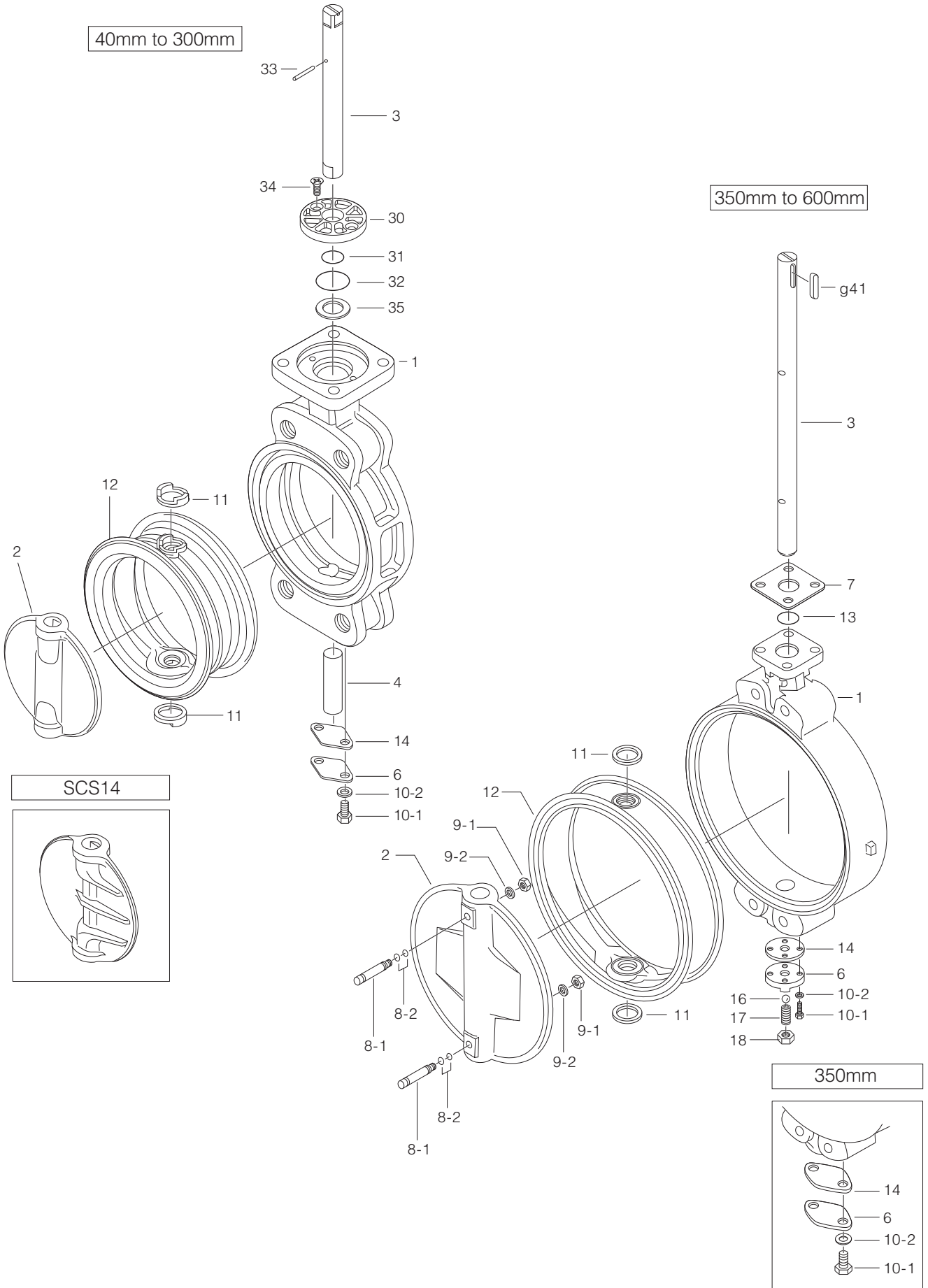

705G Parts list

■ 705G Parts list (40mm to 300mm)

No.	Description	Q'ty	Remarks
1	Body	1	
2	Disc	1	
3	Upper stem	1	
4	Lower stem	1	See Remark 2.
6	Bottom cover	1	
10-1	Hexagon bolt	2	
10-2	Spring washer	2	
★ 11	Secondary ring	2	
★ 12	Seat ring	1	
★ 14	Gasket	1	
★ 30	Bushing	1	
★ 31	O-ring	1	
★ 32	O-ring	1	
33	Spring pin	1	
34	Machine screw	2	
35	Plate	1	

■ 705G Parts list (350mm to 600mm)

No.	Description	Q'ty	Remarks
1	Body	1	
2	Disc	1	
3	Stem	1	
6	Bottom cover	1	
7	Retainer plate	1	
★ 8-1	Taper bolt	2	
★ 8-2	O-ring	4	
★ 9-1	Hexagon nut	2	
★ 9-2	Spring washer	2	
10-1	Hexagon bolt	2	350mm
		4	400mm to 600mm
10-2	Spring washer	2	350mm
		4	400mm to 600mm
★ 11	Secondary ring	2	350mm
11	Secondary ring	2	400mm to 600mm
★ 12	Seat ring	1	
★ 13	O-ring	1	
★ 14	Gasket	1	
16	Ball	1	Only 400mm to 600mm
17	Hollow bolt	1	Only 400mm to 600mm
18	Lock nut	1	Only 400mm to 600mm
g41	Key	1	

Remark 1: The ★ indicates recommended spare parts. They are supplied as "Seat ring set".

Remark 2: When the disc material is PPS, the lower stem length of types 40mm to 100mm is different from standard.

Butterfly Valve
TRITEC
TT2
334A
344Q
302A/303Q
304A/304Q
304YA
302Y/304Y
304M (HLV)
507V/508V
DTM
846T/847T/847Q
841T/842T
700Z
700G/704G/705G
72WG/72SG/72LG
731P/732P/732Q/752W
731R
700E/700K/700S
704G/722F/720F
227P
907T/908H (MKT)
903L/901C/905C (Bata-check)

700G / 704G / 705G Actuator Selection Chart

700G/704G/705G

Model	Category	Size (mm / inch)																								
		40	50	65	80	100	125	150	200	250	300	350	400	450	500	550 ^{**1}	600									
		1 1/2	2	2 1/2	3	4	5	6	8	10	12	14	16	18	20	22	24									
1T	Standard	1T-1			1T-2			1T-3																		
	Heavy duty	1T-1			1T-2			1T-3																		
2U	Standard	2U-0		2U-1		2U-2		2U-3		2U-4		2U-5		2U-6												
	Heavy duty	2U-0		2U-1		2U-2		2U-3		2U-4		2U-5		2U-6												
2G,2R	Standard	2G-1				2G-2			2G-3		2G-4	2R-3			2R-4											
	Heavy duty	2G-1				2G-2			2G-3		2G-4	2R-3			2R-4											
7E,3A	Standard	T35		T85			T200			T380		T750		TGA-125	TGA-140	TGA-160		TGA-180								
	Heavy duty	T35		T85			T200			T380		T750		TGA-125	TGA-140	TGA-160		TGA-180								
7G,7F 3U,3K	Standard	T85S	T200S		T380S			T750S		TG-10S			TG-12S		TG-14S		TG-20S									
	Heavy duty	T85S	T200S		T380S			T750S		TG-10S			TG-12S		TG-14S		TG-20S									
4I ^{**}	ON-OFF	4I-00		4I-0		4I-1	4I-2	4I-2.5		4I-3		4I-4														
	Control	4I-00		4I-0		4I-1	4I-2	4I-2.5		4I-3		4I-4														
4J,4L	Standard	SRJ-010				SRJ-020			SRJ-060			LTKD-01 0.2kW /MGH-3		LTKD-01 0.4kW /MGH-3		LTKD-02 0.75kW /MGH-4	LTKD-05 0.75kW /MGH-4									
	Heavy duty	SRJ-010				SRJ-020			SRJ-060			LTKD-01 0.2kW /MGH-3		LTKD-01 0.4kW /MGH-3		LTKD-02 0.75kW /MGH-4	LTKD-05 0.75kW /MGH-4									

Remark^{**}: For 400mm with the accessories below, type 4I-4 should be selected.

- Micom unit
- Servo unit
- Speed control unit
- Potentiometer

^{**1} 550mm is available for 700G and 705G only.

Selection criteria	Standard
	Heavy duty

Select when none of the following heavy duty items apply.

Select when any of the following items apply.

- ① Powder or high viscosity fluid (crude oil, etc.)
- ② Control specification (with positioner)
- ③ Emergency open valve or pipe dead end valve

700G / 704G / 705G Pressure-Temperature Rating

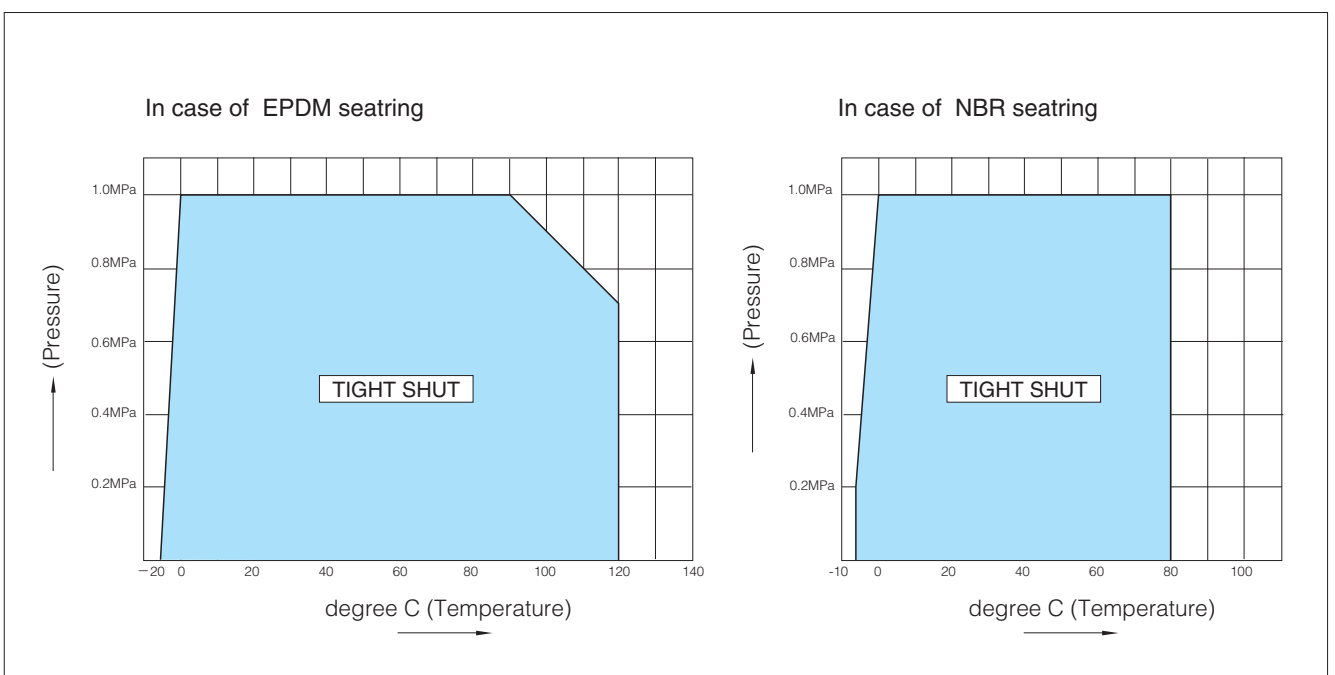

700G Bare shaft (01: 40mm to 300mm, 02: 350mm to 600mm)

700G

Shaft type	Nominal size		Dimension (mm)													Approx. Mass (kg)
	mm	inch	ϕd	ϕD	L	H ₁	H ₂	a ₁	a ₂	□S ₁	ϕd_2	b	t ₂	t	Top flange	
01	40	1 1/2	45	80	35	61	132	21.5	10.5	8	10	—	—	12	F07	1.5
	50	2	56	90	43	68	138	21.5	10.5	8	10	—	—	12	F07	1.8
	65	2 1/2	69	115	46	79	151	21.5	10.5	8	10	—	—	12	F07	2.5
	80	3	84	126	46	86	156	22.5	11.5	10	12	—	—	12	F07	2.6
	100	4	104	146	52	103	167	22.5	11.5	12	14	—	—	12	F07	3.4
	125	5	130	181	56	118	191	27.5	16.5	14	16	—	—	14	F10	5.4
	150	6	153.5	211	56	135	202	27.5	16.5	14	18	—	—	14	F10	7
	200	8	199	256	60	177	227	30	20	18	22	—	—	14	F10	10.4
	250	10	253	322	68	215	280	35	30	24	28	—	—	14	F10	18
300	12	302	367	78	253	312	35	30	24	32	—	—	16	F12	25	
02	350	14	337	410	78	276	348	48	43	—	32	10	3	23	F14	42
	400	16	394	467	102	338	383	54	48	—	40	12	3	23	F14	64
	450	18	441	525	114	368	413	65	59	—	46	14	3.5	23	F14	87
	500	20	492	580	127	403	453	79	73	—	50	14	3.5	28	F14	114
	550	22	524.2	633	150	416	460	79	73	—	55	16	4	25	F16	178.6
	600	24	584	682	154	458	528	79	73	—	55	16	4	28	F16	191

Top flange dimension list

Flange type	□S	ϕC_1	N	B.H.
F07	70	70	4	9
F10	102	102	4	11
F12	125	125	4	13
F14	140	140	4	19
F16	165	165	4	23

Shaft type
 01 : Square
 02 : Round (Key way)

700G 40mm~300mm

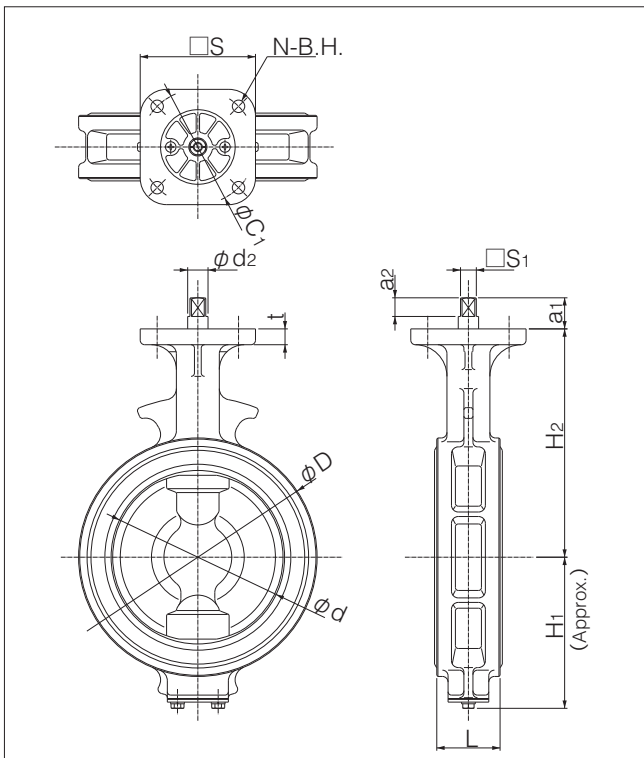

700G 350mm~500mm

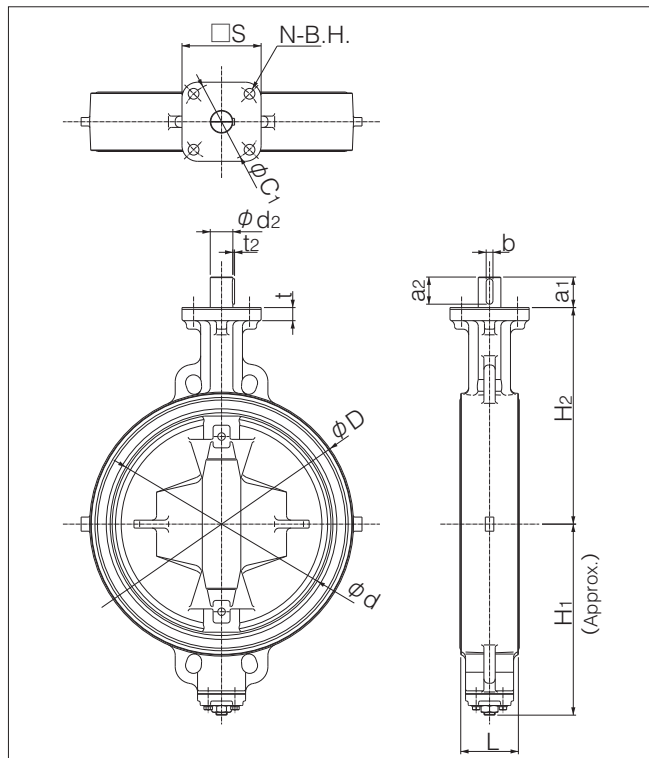

Butterfly Valve
TRITEC
TT2
334A
344Q
302A/303Q
304A/304Q
304YA
302Y/304Y
304M (HLV)
507V/508V
DTM
846T/847T/847Q
841T/842T
700Z
700G/704G/705G
72WG/72SG/72LG
731P/732P/732Q/752W
731R
700E/700K/700S
704G/722F/720F
227P
907T/908H (MKT)
903L/901C/905C (Bata-check)

704G Bare shaft (01: 50mm to 300mm, 02: 350mm to 600mm)

704G

Shaft type	Nominal size		Dimension (mm)													Approx. Mass (kg)	
	mm	inch	ϕd	ϕD		L	H ₁	H ₂	a ₁	a ₂	$\square S_1$	ϕd_2	b	t ₂	t		Top flange
				JIS5K	JIS10K												
01	50	2	56	90	90	43	85	138	21.5	10.5	8	10	—	—	12	F07	2.5
	65	2 1/2	69	115	115	46	94	151	21.5	10.5	8	10	—	—	12	F07	3.5
	80	3	84	126	190	46	109	156	22.5	11.5	10	12	—	—	12	F07	4 (4.8)
	100	4	104	223	223	52	117	167	22.5	11.5	12	14	—	—	12	F07	6.7
	125	5	130	250	250	56	143	191	27.5	16.5	14	16	—	—	14	F10	8.8
	150	6	153.5	276	276	56	164	202	27.5	16.5	14	18	—	—	14	F10	10.4
	200	8	199	334	329	60	176	227	30	20	18	22	—	—	14	F10	16.3
	250	10	253	402	402	68	215	280	35	30	24	28	—	—	14	F10	27
	300	12	302	472	438	78	253	312	35	30	24	32	—	—	16	F12	39
02	350	14	337	533	505	78	276	348	48	43	—	32	10	3	23	F14	66
	400	16	394	597	597	102	338	383	54	48	—	40	12	3	23	F14	107
	450	18	441	634	626	114	368	413	65	59	—	46	14	3.5	23	F14	128
	500	20	492	696	696	127	403	453	79	73	—	50	14	3.5	28	F14	170
	600	24	584	820	795	154	458	528	79	73	—	55	16	4	28	F16	275 (269)

Remark: In case of JIS10K the mass with round bracket.

Top flange dimension list

Flange type	$\square S$	ϕC_1	N	B.H.
F07	70	70	4	9
F10	102	102	4	11
F12	125	125	4	13
F14	140	140	4	19
F16	165	165	4	23

Shaft type	01 : Square
	02 : Round (Key way)

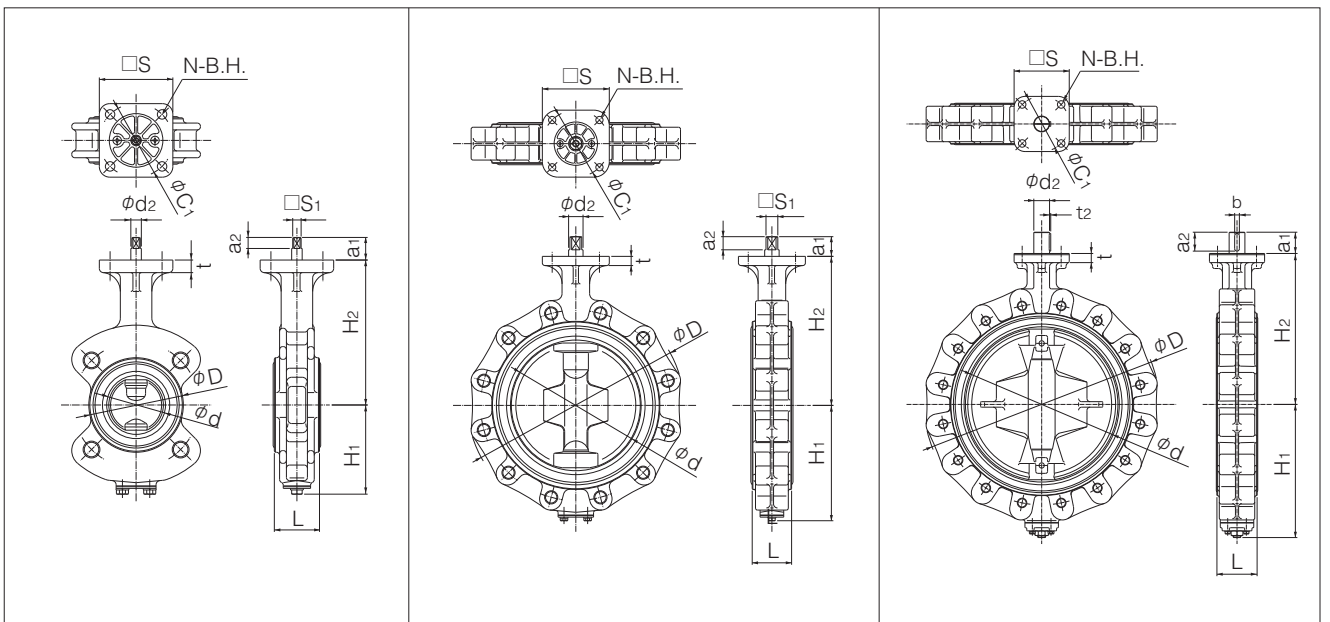

705G Bare shaft(01: 40mm to 300mm, 02: 350mm to 600mm)

705G

Shaft type	Nominal size		Dimension (mm)													Approx. Mass (kg)
	mm	inch	ϕd	ϕD	L	H ₁	H ₂	a ₁	a ₂	$\square S_1$	ϕd_2	b	t ₂	t	Top flange	
01	40	1 1/2	45	80	35	61	132	21.5	10.5	8	10	—	—	12	F07	2.0
	50	2	56	90	43	85	138	21.5	10.5	8	10	—	—	12	F07	2.5
	65	2 1/2	69	115	46	94	151	21.5	10.5	8	10	—	—	12	F07	3.5
	80	3	84	126	46	109	156	22.5	11.5	10	12	—	—	12	F07	4
	100	4	104	146	52	117	167	22.5	11.5	12	14	—	—	12	F07	5
	125	5	130	181	56	143	191	27.5	16.5	14	16	—	—	14	F10	8
	150	6	153.5	211	56	164	202	27.5	16.5	14	18	—	—	14	F10	11
	200	8	199	256	60	186	227	30	20	18	22	—	—	14	F10	15
	250	10	253	322	68	215	280	35	30	24	28	—	—	14	F10	24
300	12	302	367	78	253	312	35	30	24	32	—	—	16	F12	31	
02	350	14	337	410	78	276	348	48	43	—	32	10	3	23	F14	47
	400	16	394	467	102	338	383	54	48	—	40	12	3	23	F14	72
	450	18	441	525	114	368	413	65	59	—	46	14	3.5	23	F14	96
	500	20	492	580	127	403	453	79	73	—	50	14	3.5	28	F14	127
	550	22	524.2	633	150	416	460	79	73	—	55	16	4	25	F16	178.6
	600	24	584	682	154	458	528	79	73	—	55	16	4	28	F16	191

Top flange dimension list

Flange type	$\square S$	ϕC_1	N	B.H.
F07	70	70	4	9
F10	102	102	4	11
F12	125	125	4	13
F14	140	140	4	19
F16	165	165	4	23

Shaft type
 01 : Square
 02 : Round (Key way)

705G 40mm~300mm

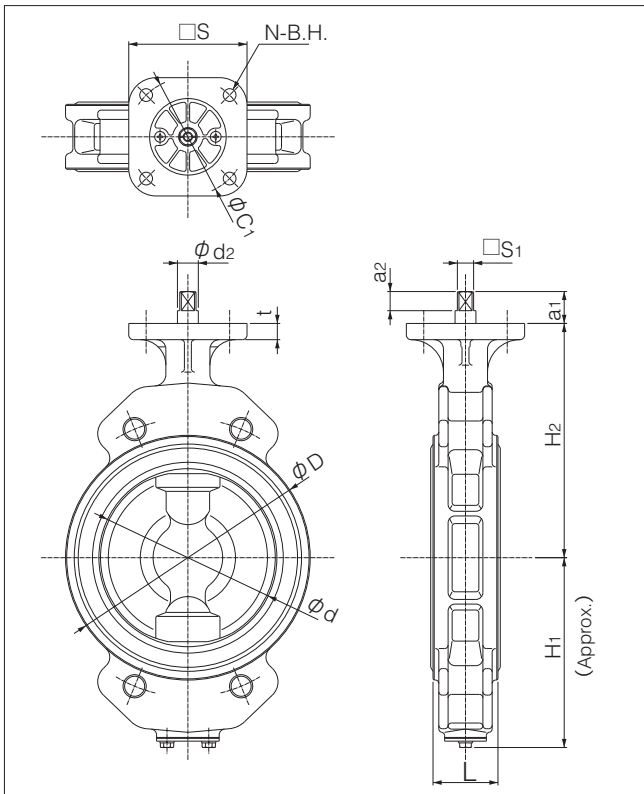

705G 350mm~600mm

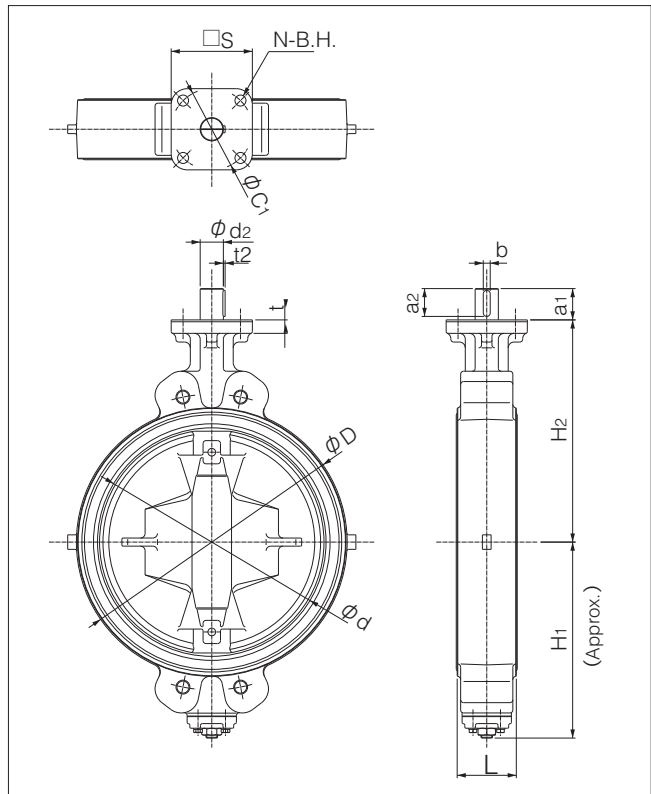

Butterfly Valve
TRITEC
TT2
334A
344Q
302A/303Q
304A/304Q
304YA
302Y/304Y
304M (HLV)
507V/508V
DTM
846T/847T/847Q
841T/842T
700Z
700G/704G/705G
72WG/72SG/72LG
731P/732P/732Q/752W
731R
700E/700K/700S
704G/722F/720F
227P
907T/908H (MKT)
903L/901C/905C (Bata-check)

Lock lever type 700G-1T (40mm to 200mm)

Nominal size		Dimension (mm)							Lever type	Approx.Mass (kg)
mm	inch	ϕd	ϕD	L	H ₁	H ₂	H ₃	W		
40	1 1/2	45	80	35	61	132	66	200	1T-1	2.1
50	2	56	90	43	68	138	66	200	1T-1	2.4
65	2 1/2	69	115	46	79	151	66	200	1T-1	3.1
80	3	84	126	46	86	156	66	200	1T-1	3.2
100	4	104	146	52	103	167	66	200	1T-1	4
125	5	130	181	56	118	191	92	300	1T-2	6.7
150	6	153.5	211	56	135	202	92	300	1T-2	8.3
200	8	199	256	60	177	227	97	350	1T-3	12.1

700G-1T

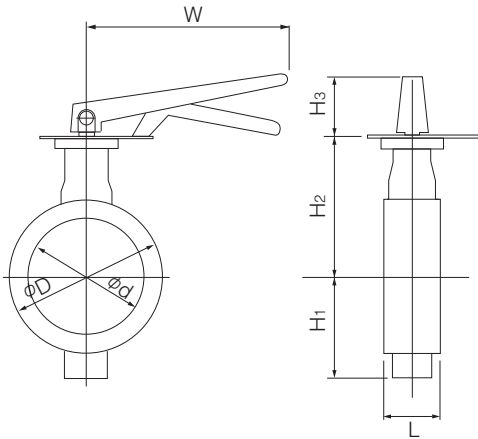

1T Installation direction

1TLS (standard)	1TLR	1TRS	1TRR
1TXS	1TXR	1TVS	1TVR

Worm gear type 700G-2U (40mm to 600mm)

Nominal size		Dimension (mm)										Gear type	Approx. Mass (kg)
mm	inch	ϕd	ϕD	L	H ₁	H ₂	H ₃	E	K	F	W		
40	1 1/2	45	80	35	61	132	29.5	36	46	160	100	2U-0	3.8
50	2	56	90	43	68	138	29.5	36	46	160	100	2U-0	4.1
65	2 1/2	69	115	46	79	151	29.5	36	46	160	100	2U-0	4.8
80	3	84	126	46	86	156	29.5	36	46	160	100	2U-1	4.9
100	4	104	146	52	103	167	29.5	36	46	160	100	2U-1	5.7
125	5	130	181	56	118	191	34.5	44	53	173.5	160	2U-2	9.6
150	6	153.5	211	56	135	202	34.5	44	53	173.5	160	2U-2	11.2
200	8	199	256	60	177	227	41.5	67	75	198	200	2U-3	18
250	10	253	322	68	215	280	41.5	67	75	198	200	2U-3	26
300	12	302	367	78	253	312	48	87.5	90	222.5	200	2U-4	39
350	14	337	410	78	276	348	48	87.5	90	222.5	280	2U-4	58
400	16	394	467	102	338	383	50	90	105	266	280	2U-5	80
450	18	441	525	114	368	413	50	90	105	266	280	2U-5	103
500	20	492	580	127	403	453	50	90	105	266	280	2U-5	130
550	22	524.2	633	150	416	460	61	113	140	352	400	2U-6	210
600	24	584	682	154	458	528	61	113	140	352	400	2U-6	222

700G-2U

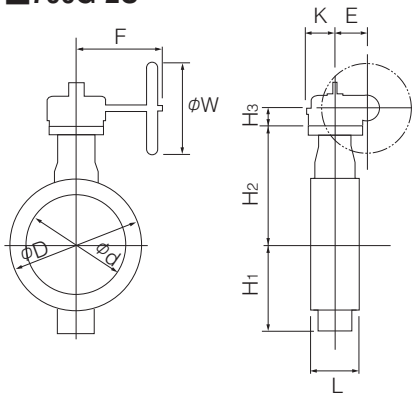

2U Installation direction

2U A (standard)	2U AR	2U B	2U BR

Butterfly Valve

TRITEC

TT2

334A

344Q

302A/303Q

304A/304Q

304YA

302Y/304Y

304M (HLV)

507V/508V

DTM

846T/847T/847Q

841T/842T

700Z

700G/704G/705G

72WG/72SG/72LG

731P/732P/732Q/752W

731R

700E/700K/700S

704G/722F/720F

227P

907T/908H (MKT)

903L/901C/905C (Bata-check)

Center handle type 700G-2G (40mm to 300mm) / 700G-2R (350mm to 600mm)

Nominal size		Dimension (mm)							Center handle type	Approx. Mass (kg)
mm	inch	ϕd	ϕD	L	H ₁	H ₂	H ₃	W		
40	1 1/2	45	80	35	61	132	136	100	2G-1	4.4
50	2	56	90	43	68	138	136	100	2G-1	4.7
65	2 1/2	69	115	46	79	151	136	100	2G-1	5.4
80	3	84	126	46	86	156	136	100	2G-1	5.5
100	4	104	146	52	103	167	136	100	2G-1	6.3
125	5	130	181	56	118	191	133	100	2G-2	9.2
150	6	153.5	211	56	135	202	133	100	2G-2	10.8
200	8	199	256	60	177	227	151	200	2G-3	17.5
250	10	253	322	68	215	280	151	200	2G-3	25.1
300	12	302	367	78	253	312	161	200	2G-4	32.1
350	14	337	410	78	276	348	409	355	2R-3	75
400	16	394	467	102	338	383	409	355	2R-3	97
450	18	441	525	114	368	413	409	355	2R-3	121
500	20	492	580	127	403	453	409	355	2R-3	148
550	22	524.2	633	150	416	460	498	450	2R-4	262
600	24	584	682	154	458	528	498	450	2R-4	244

700G-2G/2R

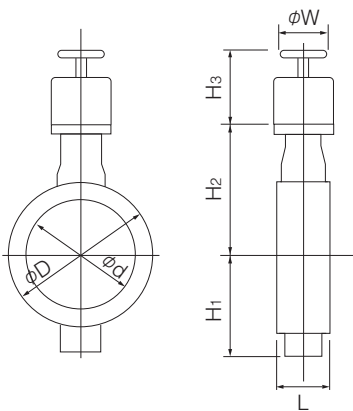

Double-acting pneumatic cylinder type 700G-7E (40mm to 350mm)

Standard

Nominal size		Dimension (mm)										Center handle type	Approx. Mass (kg)
mm	inch	ϕd	ϕD	L	H ₁	H ₂	H ₃	A	P	f ₁	f ₂		
40	1 1/2	45	80	35	61	132	125	228	116	57	29	T35	4
50	2	56	90	43	68	138	125	228	116	57	29	T35	4
65	2 1/2	69	115	46	79	151	125	228	116	57	29	T35	5
80	3	84	126	46	86	156	168	276	142	75	47	T85	8
100	4	104	146	52	103	167	168	276	142	75	47	T85	8
125	5	130	181	56	118	191	168	276	142	75	47	T85	10
150	6	153.5	211	56	135	202	203	346	176	79	57	T200	15
200	8	199	256	60	177	227	231	423	214	91	69	T380	25
250	10	253	322	68	215	280	231	423	214	91	69	T380	32
300	12	302	367	78	253	312	269	546	270	118	85	T750	49
350	14	337	410	78	276	348	269	546	270	118	85	T750	74

Heavy duty

Nominal size		Dimension (mm)										Center handle type	Approx. Mass (kg)
mm	inch	ϕd	ϕD	L	H ₁	H ₂	H ₃	A	P	f ₁	f ₂		
40	1 1/2	45	80	35	61	132	125	228	116	57	29	T35	4
50	2	56	90	43	68	138	125	228	116	57	29	T35	4
65	2 1/2	69	115	46	79	151	125	228	116	57	29	T35	5
80	3	84	126	46	86	156	168	276	142	75	47	T85	8
100	4	104	146	52	103	167	203	346	176	79	57	T200	12
125	5	130	181	56	118	191	203	346	176	79	57	T200	14
150	6	153.5	211	56	135	202	203	346	176	79	57	T200	15
200	8	199	256	60	177	227	231	423	214	91	69	T380	25
250	10	253	322	68	215	280	231	423	214	91	69	T380	32
300	12	302	367	78	253	312	269	546	270	118	85	T750	49

Selection criteria	Standard	Select when none of the following heavy duty items apply.
	Heavy duty	Select when any of the following items apply. ① Powder or high viscosity fluid (crude oil, etc.) ② Control specification (with positioner) ③ Emergency open valve or pipe dead end valve ④ Air or Gas

700G-7E

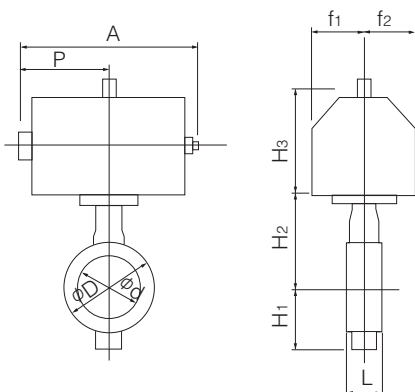

7E Installation direction

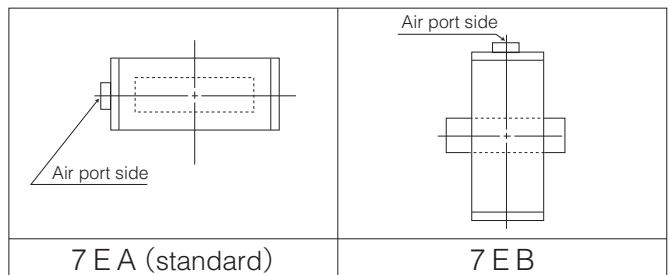

Butterfly Valve
TRITEC
TT2
334A
344Q
302A/303Q
304A/304Q
304YA
302Y/304Y
304M (HLV)
507V/508V
DTM
846T/847T/847Q
841T/842T
700Z
700G/704G/705G
72WG/72SG/72LG
731P/732P/732Q/752W
731R
700E/700K/700S
704G/722F/720F
227P
907T/908H (MKT)
903L/901C/905C (Bata-check)

Double-acting pneumatic cylinder type 700G-3A (350mm to 600mm)

Standard

Nominal size		Dimension (mm)										Cylinder type	Approx. Mass (kg)
mm	inch	ϕd	ϕD	L	H ₁	H ₂	H ₃	A	P	f ₁	f ₂		
400	16	394	467	102	338	383	364	754	381	100	164	TGA-125	101
450	18	441	525	114	368	413	412	840	432	100	180	TGA-140	138
500	20	492	580	127	403	453	465	954	483	130	202	TGA-160	204
550	22	524.2	633	150	416	460	465	954	483	130	203	TGA-160	287
600	24	584	682	154	458	528	478	1069	543	130	218	TGA-180	330

Heavy duty

Nominal size		Dimension (mm)										Cylinder type	Approx. Mass (kg)
mm	inch	ϕd	ϕD	L	H ₁	H ₂	H ₃	A	P	f ₁	f ₂		
350	14	337	410	78	276	348	364	754	381	100	164	TGA-125	80
400	16	394	467	102	338	383	412	840	432	100	180	TGA-140	116
450	18	441	525	114	368	413	465	954	483	130	202	TGA-160	188
500	20	492	580	127	403	453	465	954	483	130	202	TGA-160	204
550	22	524.2	633	150	416	460	478	1069	543	130	221	TGA-180	328
600	24	584	682	154	458	528	525	1175	599	160	253	TGA-200	390

700G-3A

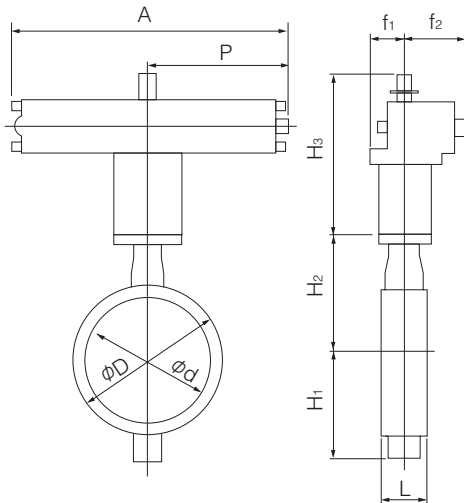

Selection criteria	Standard	Select when none of the following heavy duty items apply.
	Heavy duty	Select when any of the following items apply. ① Powder or high viscosity fluid (crude oil, etc.) ② Control specification (with positioner) ③ Emergency open valve or pipe dead end valve ④ Air or Gas

3A Installation direction

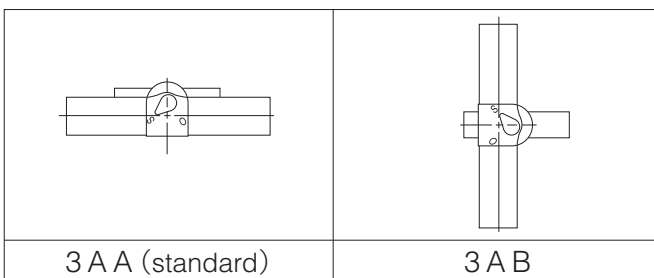

Single-acting pneumatic cylinder type 700G-7G (Air to open: 40mm to 250mm) / 700G-7F (Air to close: 40mm to 250mm)

■ Standard

Nominal size		Dimension (mm)										Cylinder type	Approx. Mass (kg)
mm	inch	ϕd	ϕD	L	H ₁	H ₂	H ₃	A	P	f ₁	f ₂		
40	1 1/2	45	80	35	61	132	168	364	183	75	47	T85S	8
50	2	56	90	43	68	138	168	364	183	75	47	T85S	8
65	2 1/2	69	115	46	79	151	203	449	226	79	57	T200S	14
80	3	84	126	46	86	156	203	449	226	79	57	T200S	14
100	4	104	146	52	103	167	203	449	226	79	57	T200S	15
125	5	130	181	56	118	191	231	550	276	91	69	T380S	25
150	6	153.5	211	56	135	202	231	550	276	91	69	T380S	26
200	8	199	256	60	177	227	269	723	360	118	85	T750S	43
250	10	253	322	68	215	280	269	723	360	118	85	T750S	51

■ Heavy duty

Nominal size		Dimension (mm)										Cylinder type	Approx. Mass (kg)
mm	inch	ϕd	ϕD	L	H ₁	H ₂	H ₃	A	P	f ₁	f ₂		
40	1 1/2	45	80	35	61	132	168	364	183	75	47	T85S	8
50	2	56	90	43	68	138	168	364	183	75	47	T85S	8
65	2 1/2	69	115	46	79	151	203	449	226	79	57	T200S	14
80	3	84	126	46	86	156	203	449	226	79	57	T200S	14
100	4	104	146	52	103	167	231	550	276	91	69	T380S	23
125	5	130	181	56	118	191	231	550	276	91	69	T380S	25
150	6	153.5	211	56	135	202	269	723	360	118	85	T750S	40

Selection criteria	Standard	Select when none of the following heavy duty items apply.
	Heavy duty	Select when any of the following items apply. ① Powder or high viscosity fluid (crude oil, etc.) ② Control specification (with positioner) ③ Emergency open valve or pipe dead end valve ④ Air or Gas

■ 700G-7F

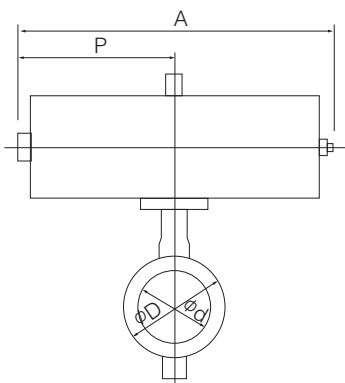

■ 700G-7G

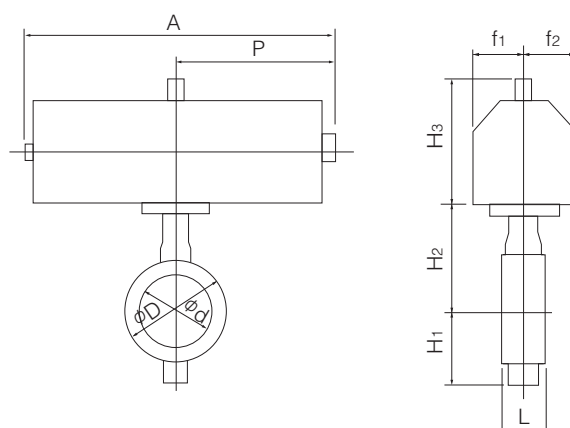

■ 7F Installation direction

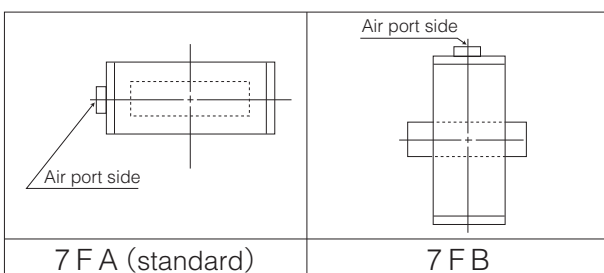

■ 7G Installation direction

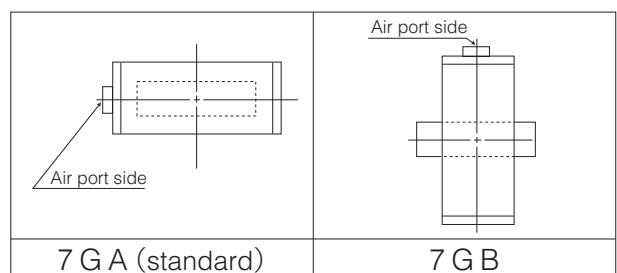

Butterfly Valve
TRITEC
TT2
334A
344Q
302A/303Q
304A/304Q
304YA
302Y/304Y
304M (HLV)
507V/508V
DTM
846T/847T/847Q
841T/842T
700Z
700G/704G/705G
72WG/72SG/72LG
731P/732P/732Q/752W
731R
700E/700K/700S
704G/722F/720F
227P
907T/908H (MKT)
903L/901C/905C (Bata-check)

Single-acting pneumatic cylinder type 700G-3U (Air to open: 200mm to 600mm) / 700G-3K (Air to close: 200mm to 600mm)

Standard

Nominal size		Dimension (mm)										Cylinder type	Approx. Mass (kg)
mm	inch	ϕd	ϕD	L	H ₁	H ₂	H ₃	A	P	f ₁	f ₂		
250	10	253	322	68	215	280	307	945	585	70	165	TG-10S	81
300	12	302	367	78	253	312	307	1080	720	94	206	TG-12S	126
350	14	337	410	78	276	348	307	1080	720	94	206	TG-12S	143
400	16	394	467	102	338	383	340	1255	865	131	257	TG-14S	262
450	18	441	525	114	368	413	340	1255	865	131	257	TG-14S	285
500	20	492	580	127	403	453	474	1655	1095	164	348	TG-20S	525
550	22	524.2	633	150	416	460	474	1655	1095	164	348	TG-20S	594
600	24	584	682	154	458	528	474	1655	1095	164	348	TG-20S	602

Heavy duty

Nominal size		Dimension (mm)										Cylinder type	Approx. Mass (kg)
mm	inch	ϕd	ϕD	L	H ₁	H ₂	H ₃	A	P	f ₁	f ₂		
200	8	199	256	60	177	227	307	945	585	70	165	TG-10S	73
250	10	253	322	68	215	280	307	1080	720	94	206	TG-12S	119
300	12	302	367	78	253	312	307	1080	720	94	206	TG-12S	126
350	14	337	410	78	276	348	340	1255	865	131	257	TG-14S	239
400	16	394	467	102	338	383	340	1255	865	131	257	TG-14S	262
450	18	441	525	114	368	413	474	1655	1095	164	348	TG-20S	498
500	20	492	580	127	403	453	474	1655	1095	164	348	TG-20S	525
550	22	524.2	633	150	416	460	474	1655	1095	164	348	TG-20S	594
600	24	584	682	154	458	528	474	1655	1095	164	348	TG-20S	602

Selection criteria	Standard	Select when none of the following heavy duty items apply.
	Heavy duty	Select when any of the following items apply. ① Powder or high viscosity fluid (crude oil, etc.) ② Control specification (with positioner) ③ Emergency open valve or pipe dead end valve ④ Air or Gas

700G-3U

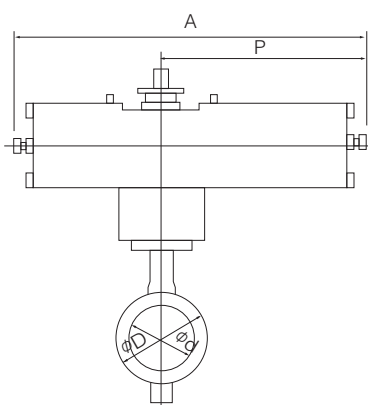

700G-3K

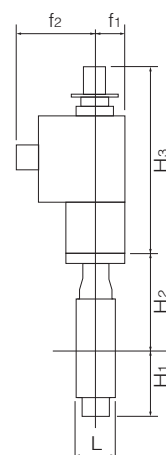
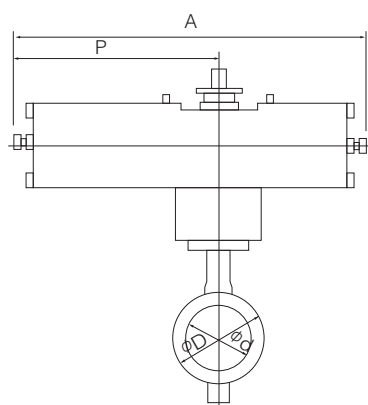

3U Installation direction

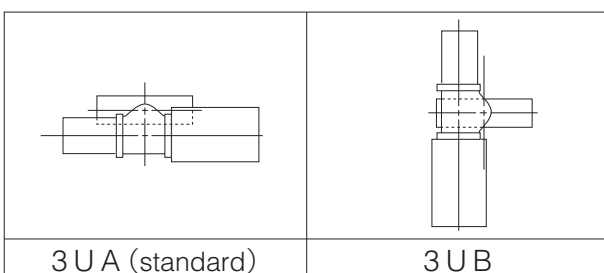

3K Installation direction

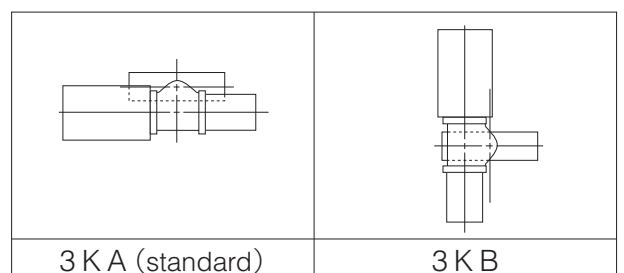

Single phase electric motor type 700G-4I (40mm to 500mm)

Nominal size		Dimension (mm)										Motor type	Approx. Mass (kg)
mm	inch	ϕd	ϕD	L	H ₁	H ₂	H ₃	A	P	F	K		
40	1 1/2	45	80	35	61	132	120	161	84	58	45	4 I-00	4
							176	202	100	85	54	4 I-0	5.7
50	2	56	90	43	68	138	120	161	84	58	45	4 I-00	4.3
							176	202	100	85	54	4 I-0	6
65	2 1/2	69	115	46	79	151	150	202	100	85	54	4 I-0	6.7
80	3	84	126	46	86	156	150	202	100	85	54	4 I-0	6.8
100	4	104	146	52	103	167	165	252	138	126	65	4 I-1	9.8
125	5	130	181	56	118	191	198	310	167	154	85	4 I-2	16.6
150	6	153.5	211	56	135	202	198	310	167	154	85	4 I-2	18.2
200	8	199	256	60	177	227	198	310	167	154	85	4 I-2.5	21.6
250	10	253	322	68	215	280	198	310	167	154	85	4 I-2.5	30.8
300	12	302	367	78	253	312	230	388	223	246	136	4 I-3	48.2
350	14	337	410	78	276	348	230	388	223	246	136	4 I-3	65
400	16	394	467	102	338	383	230	388	223	246	136	4 I-3	87
							255	388	223	246	136	4 I-4	93
450	18	441	525	114	368	413	230	388	223	246	136	4 I-4	116
500	20	492	580	127	403	453	230	388	223	246	136	4 I-4	143

Note 1: For nominal size 40, 50 mm type (for control), the 4I-0 type should be selected. (The 4I-00 type is only designed for ON-OFF operation.)

Remark: For 400mm type with the accessories below, type 4I-4 should be selected.

- Micom unit
- Servo unit
- Speed control unit
- Potentiometer

700G-4 I

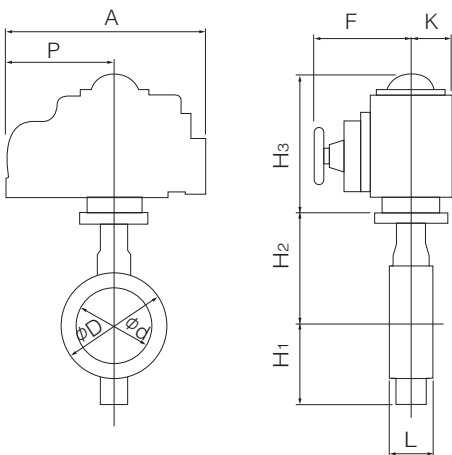

4I Installation direction

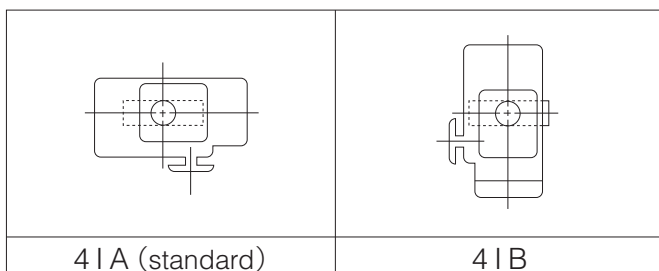

Butterfly Valve
TRITEC
TT2
334A
344Q
302A/303Q
304A/304Q
304YA
302Y/304Y
304M (HLV)
507V/508V
DTM
846T/847T/847Q
841T/842T
700Z
700G/704G/705G
72WG/72SG/72LG
731P/732P/732Q/752W
731R
700E/700K/700S
704G/722F/720F
227P
907T/908H (MKT)
903L/901C/905C (Bata-check)

Three phase motor actuator type 700G-4J (40mm to 300mm)

Nominal size		Dimension (mm)											Motor type	Approx. Mass (kg)
mm	inch	ϕd	ϕD	L	H ₁	H ₂	H ₃	H ₄	A	P	F	K		
40	1 1/2	45	80	35	61	132	218	3.2	353	167	286	104	SRJ-010	15.2
50	2	56	90	43	68	138	218	3.2	353	167	286	104	SRJ-010	15.5
65	2 1/2	69	115	46	79	151	218	3.2	353	167	286	104	SRJ-010	16.2
80	3	84	126	46	86	156	218	3.2	353	167	286	104	SRJ-010	16.3
100	4	104	146	52	103	167	218	3.2	353	167	286	104	SRJ-010	16.9
125	5	130	181	56	118	191	218	15	353	167	286	104	SRJ-020	19.6
150	6	153.5	211	56	135	202	218	15	353	167	286	104	SRJ-020	21
200	8	199	256	60	177	227	235	3.2	393	191	330	130	SRJ-060	38
250	10	253	322	68	215	280	235	3.2	393	191	330	130	SRJ-060	50
300	12	302	367	78	253	312	235	20	393	191	330	130	SRJ-060	61

700G-4J

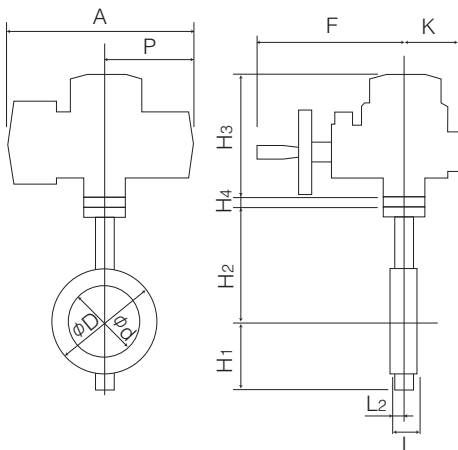

4J Installation direction

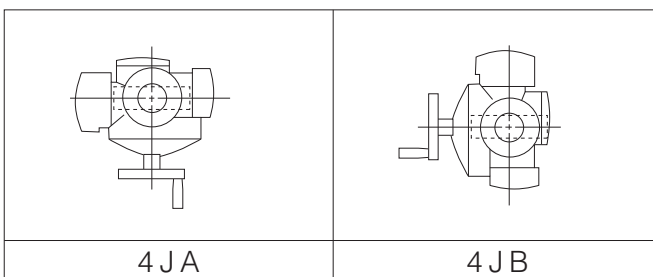

Three phase motor actuator type 700G-4L (350mm to 600mm)

Nominal size		Dimension (mm)											Motor type	Approx. Mass (kg)
mm	inch	ϕd	ϕD	L	H ₁	H ₂	H ₃	E	K	F	M	P		
350	14	337	410	78	276	348	487	117	164	533	364	230	LTKD-01 0.2kW /MGH-3	143
400	16	394	467	102	338	383	487	117	164	533	364	230	LTKD-01 0.2kW /MGH-3	165
450	18	441	525	114	368	413	487	117	164	533	357	230	LTKD-01 0.4kW /MGH-3	192
500	20	492	580	127	403	453	487	117	164	533	357	230	LTKD-01 0.4kW /MGH-3	219
550	22	524.2	633	150	416	460	558	140	198	594	375	230	LTKD-20 0.75kW /MGH-1	325
600	24	584	682	154	458	528	590	140	198	637	415	360	LTKD-05 0.75kW /MGH-4	398

■ 700G-4L

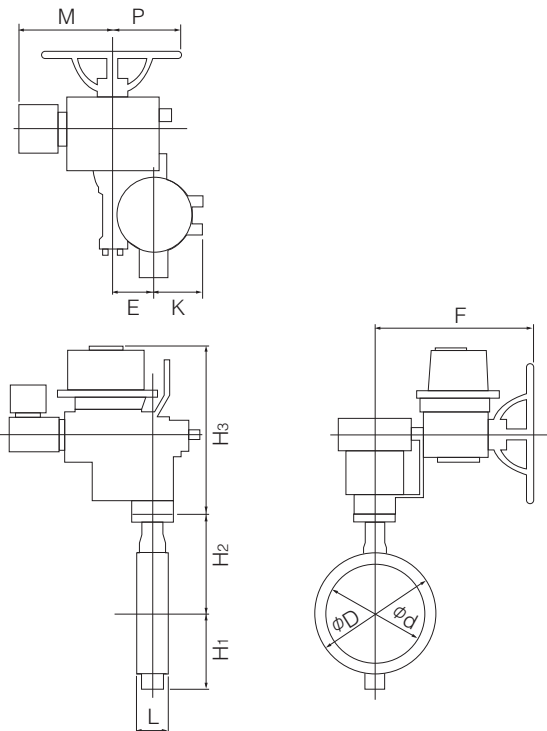

■ 4L Installation direction

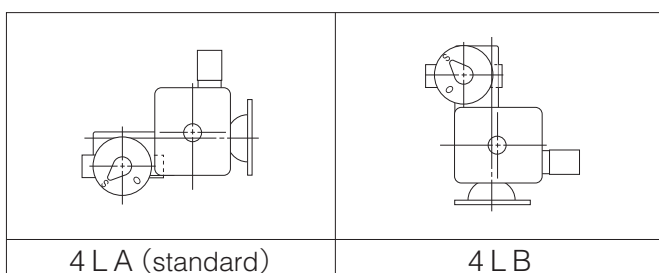

Butterfly Valve
TRITEC
TT2
334A
344Q
302A/303Q
304A/304Q
304YA
302Y/304Y
304M (HLV)
507V/508V
DTM
846T/847T/847Q
841T/842T
700Z
700G/704G/705G
72WG/72SG/72LG
731P/732P/732Q/752W
731R
700E/700K/700S
704G/722F/720F
227P
907T/908H (MKT)
903L/901C/905C (Bata-check)

Lock lever type 704G-1T (50mm to 200mm)

Nominal size		Dimension (mm)								Lever type	Approx. Mass (kg)
mm	inch	ϕd	ϕD		L	H ₁	H ₂	H ₃	W		
			JIS5K	JIS10K							
50	2	56	90	90	43	85	138	66	200	1T-1	3.1
65	2 1/2	69	115	115	46	94	151	66	200	1T-1	4.1
80	3	84	126	190	46	109	156	66	200	1T-1	4.6 (5.4)
100	4	104	223	223	52	117	167	66	200	1T-1	7.3
125	5	130	250	250	56	143	191	92	300	1T-2	10.1
150	6	153.5	276	276	56	164	202	92	300	1T-2	11.7
200	8	199	334	329	60	186	227	97	350	1T-3	18

Remark: Value in brackets is for JIS 10K flanges.

704G-1T

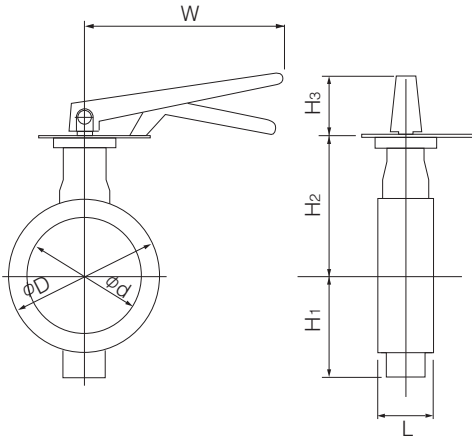

1T Installation direction

1TSL (standard)	1TLR	1TRS	1TRR
1TXS	1TXR	1TVS	1TVR

Worm gear type 704G-2U (50mm to 600mm)

Nominal size		Dimension (mm)											Gear type	Approx. Mass (kg)
mm	inch	ϕd	ϕD		L	H ₁	H ₂	H ₃	E	K	F	W		
			JIS5K	JIS10K										
50	2	56	90	90	43	85	138	29.5	36	46	160	100	2U-0	4.8
65	2 1/2	69	115	115	46	94	151	29.5	36	46	160	100	2U-0	5.8
80	3	84	126	190	46	109	156	29.5	36	46	160	100	2U-1	6.3 (7.1)
100	4	104	223	223	52	117	167	29.5	36	46	160	100	2U-1	9.0
125	5	130	250	250	56	143	191	34.5	44	53	173.5	160	2U-2	13.0
150	6	153.5	276	276	56	164	202	34.5	44	53	173.5	160	2U-2	14.6
200	8	199	334	329	60	176	227	41.5	67	75	198	200	2U-3	22.5 (24)
250	10	253	402	402	68	215	280	41.5	67	75	198	200	2U-3	35
300	12	302	472	438	78	253	312	48	87.5	90	222.5	200	2U-4	53
350	14	337	533	505	78	276	348	48	87.5	90	222.5	280	2U-4	82
400	16	394	597	597	102	338	383	50	90	105	266	280	2U-5	123
450	18	441	634	626	114	368	413	50	90	105	266	280	2U-5	144
500	20	492	696	696	127	403	453	50	90	105	266	280	2U-5	183
600	24	584	820	795	154	458	528	61	113	140	352	400	2U-6	306 (300)

Remark: Value in brackets is for JIS 10K flanges.

704G-2U

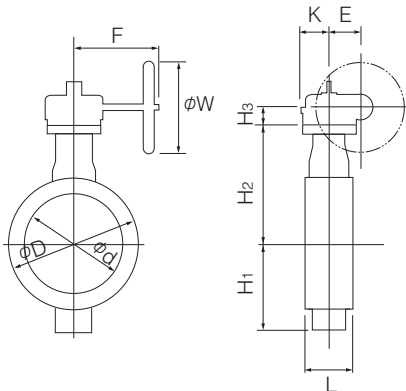

2U Installation direction

2UA (standard)	2UAR	2UB	2UBR

Butterfly Valve

TRITEC

TT2

334A

344Q

302A/303Q

304A/304Q

304YA

302Y/304Y

304M (HLV)

507V/508V

DTM

846T/847T/847Q

841T/842T

700Z

700G/704G/705G

72WG/72SG/72LG

731P/732P/732Q/752W

731R

700E/700K/700S

704G/722F/720F

227P

907T/908H (MKT)

903L/901C/905C (Bata-check)

Center handle type 704G-2G (50mm to 300mm) / 704G-2R (350mm to 600mm)

Nominal size		Dimension (mm)								Center handle type	Approx. Mass (kg)
mm	inch	ϕd	ϕD		L	H ₁	H ₂	H ₃	W		
			JIS5K	JIS10K							
50	2	56	90	90	43	85	138	136	100	2G-1	5.4
65	2 1/2	69	115	115	46	94	151	136	100	2G-1	6.4
80	3	84	126	190	46	109	156	136	100	2G-1	6.9 (7.7)
100	4	104	223	223	52	117	167	136	100	2G-1	9.6
125	5	130	250	250	56	143	191	133	100	2G-2	12.6
150	6	153.5	276	276	56	164	202	133	100	2G-2	14.2
200	8	199	334	329	60	176	227	151	200	2G-3	23.4
250	10	253	402	402	68	215	280	151	200	2G-3	40
300	12	302	472	438	78	253	312	161	200	2G-4	52 (50)
350	14	337	533	505	78	276	348	409	355	2R-3	103 (103)
400	16	394	597	597	102	338	383	409	355	2R-3	140
450	18	441	634	626	114	368	413	409	355	2R-3	166 (169)
500	20	492	696	696	127	403	453	409	355	2R-3	213
600	24	584	820	795	154	458	528	498	450	2R-4	328 (322)

Remark: Value in brackets is for JIS 10K flanges.

704G-2G/2R

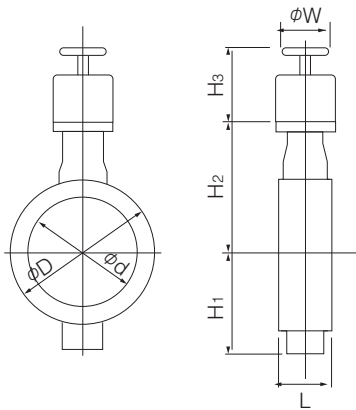

Double-acting pneumatic cylinder type 704G-7E (50mm to 350mm)

Standard

Nominal size		Dimension (mm)											Cylinder type	Approx. Mass (kg)
mm	inch	φd	φD		L	H ₁	H ₂	H ₃	A	P	f ₁	f ₂		
			JIS5K	JIS10K										
50	2	56	90	90	43	85	138	125	228	116	57	29	T35	5
65	2 1/2	69	115	115	46	94	151	125	228	116	57	29	T35	6
80	3	84	126	190	46	109	156	168	276	142	75	47	T85	11 (10)
100	4	104	223	223	52	117	167	168	276	142	75	47	T85	12
125	5	130	250	250	56	143	191	168	276	142	75	47	T85	14
150	6	153.5	276	276	56	164	202	203	346	176	79	57	T200	19
200	8	199	334	329	60	176	227	231	423	214	91	69	T380	29 (31)
250	10	253	402	402	68	215	280	231	423	214	91	69	T380	41
300	12	302	472	438	78	253	312	269	546	270	118	85	T750	63
350	14	337	533	505	78	276	348	269	546	270	118	85	T750	94

Heavy duty

Nominal size		Dimension (mm)											Cylinder type	Approx. Mass (kg)
mm	inch	φd	φD		L	H ₁	H ₂	H ₃	A	P	f ₁	f ₂		
			JIS5K	JIS10K										
50	2	56	90	90	43	85	138	125	228	116	57	29	T35	5
65	2 1/2	69	115	115	46	94	151	125	228	116	57	29	T35	6
80	3	84	126	190	46	109	156	168	276	142	75	47	T85	11 (10)
100	4	104	223	223	52	117	167	203	346	176	79	57	T200	15
125	5	130	250	250	56	143	191	203	346	176	79	57	T200	17
150	6	153.5	276	276	56	164	202	203	346	176	79	57	T200	19
200	8	199	334	329	60	176	227	231	423	214	91	69	T380	29 (31)
250	10	253	402	402	68	215	280	231	423	214	91	69	T380	41
300	12	302	472	438	78	253	312	269	546	270	118	85	T750	63

Butterfly Valve
TRITEC
TT2
334A
344Q
302A/303Q
304A/304Q
304YA
302Y/304Y
304M (HLV)
507V/508V
DTM
846T/847T/847Q
841T/842T
700Z
700G/704G/705G
72WG/72SG/72LG
731P/732P/732Q/752W
731R
700E/700K/700S
704G/722F/720F
227P
907T/908H (MKT)
903L/901C/905C (Bata-check)

Selection criteria	Standard	Select when none of the following heavy duty items apply.
	Heavy duty	Select when any of the following items apply. ① Powder or high viscosity fluid (crude oil, etc.) ② Control specification (with positioner) ③ Emergency open valve or pipe dead end valve ④ Air or Gas

704G-7E

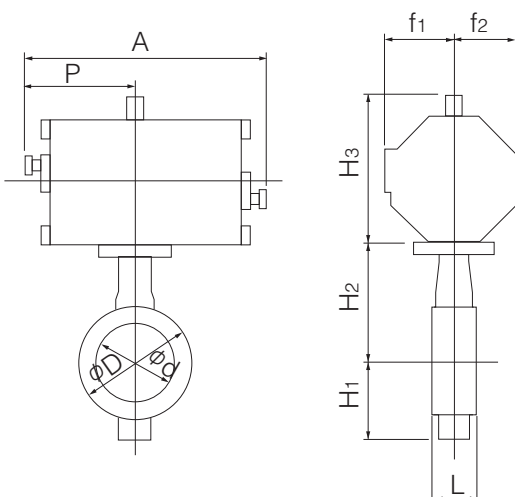

7E Installation direction

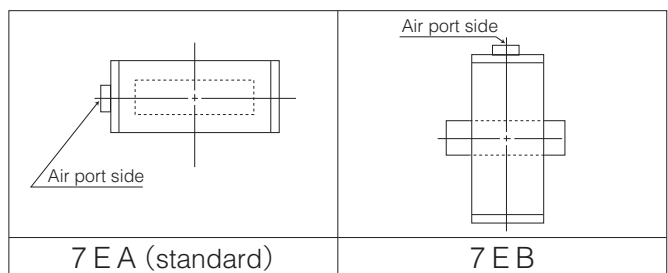

Double-acting pneumatic cylinder type 704G-3A (350mm to 600mm)

Standard

Nominal size		Dimension (mm)											Cylinder type	Approx. Mass (kg)
mm	inch	ϕd	ϕD		L	H ₁	H ₂	H ₃	A	P	f ₁	f ₂		
			JIS5K	JIS10K										
400	16	394	597	597	102	338	383	364	754	381	100	164	TGA-125	153
450	18	441	634	626	114	368	413	412	840	432	100	180	TGA-140	191
500	20	492	696	696	127	403	453	465	954	483	130	202	TGA-160	276
600	24	584	820	795	154	458	528	478	1069	543	130	218	TGA-180	414 (408)

Heavy duty

Nominal size		Dimension (mm)											Cylinder type	Approx. Mass (kg)
mm	inch	ϕd	ϕD		L	H ₁	H ₂	H ₃	A	P	f ₁	f ₂		
			JIS5K	JIS10K										
350	14	337	533	505	78	276	348	364	754	381	100	164	TGA-125	109
400	16	394	597	597	102	338	383	412	840	432	100	180	TGA-140	168
450	18	441	634	626	114	368	413	465	954	483	130	202	TGA-160	241
500	20	492	696	696	127	403	453	465	954	483	130	202	TGA-160	276
600	24	584	820	795	154	458	528	525	1175	599	160	253	TGA-200	474 (468)

Remark: Value in brackets is for JIS 10K flanges.

Selection criteria	Standard	Select when none of the following heavy duty items apply.
	Heavy duty	Select when any of the following items apply. ① Powder or high viscosity fluid (crude oil, etc.) ② Control specification (with positioner) ③ Emergency open valve or pipe dead end valve ④ Air or Gas

704G-3A

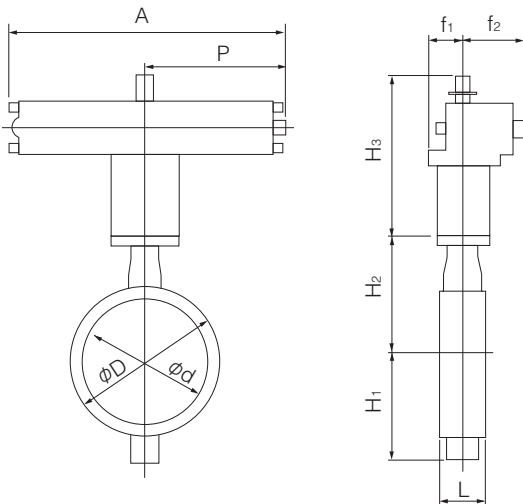

3A Installation direction

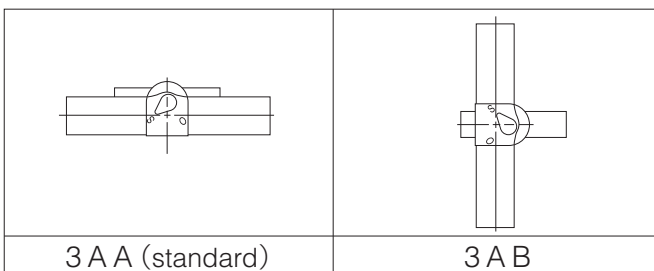

Single-acting pneumatic cylinder type 704G-7G (Air to open: 50mm to 250mm) / 704G-7F (Air to close: 50mm to 250mm)

■ Standard

Nominal size			Dimension (mm)										Cylinder type	Approx. Mass (kg)
mm	inch	ϕd	ϕD		L	H ₁	H ₂	H ₃	A	P	f ₁	f ₂		
			JIS5K	JIS10K										
50	2	56	90	90	43	85	138	168	364	183	75	47	T85S	9
65	2 1/2	69	115	115	46	94	151	203	449	226	79	57	T200S	15
80	3	84	126	190	46	109	156	203	449	226	79	57	T200S	15 (16)
100	4	104	223	223	52	117	167	203	449	226	79	57	T200S	19
125	5	130	250	250	56	143	191	231	550	276	91	69	T380S	30
150	6	153.5	276	276	56	164	202	231	550	276	91	69	T380S	33
200	8	199	334	329	60	176	227	269	723	360	118	85	T750S	52 (53)
250	10	253	402	402	68	215	280	269	723	360	118	85	T750S	65

■ Heavy duty

Nominal size			Dimension (mm)										Cylinder type	Approx. Mass (kg)
mm	inch	ϕd	ϕD		L	H ₁	H ₂	H ₃	A	P	f ₁	f ₂		
			JIS5K	JIS10K										
50	2	56	90	90	43	85	138	168	364	183	75	47	T85S	9
65	2 1/2	69	115	115	46	94	151	203	449	226	79	57	T200S	15
80	3	84	126	190	46	109	156	203	449	226	79	57	T200S	15 (16)
100	4	104	223	223	52	117	167	231	550	276	91	69	T380S	27
125	5	130	250	250	56	143	191	231	550	276	91	69	T380S	30
150	6	153.5	276	276	56	164	202	269	723	360	118	85	T750S	47

Selection criteria	Standard	Heavy duty
	Select when none of the following heavy duty items apply.	Select when any of the following items apply. ① Powder or high viscosity fluid (crude oil, etc.) ② Control specification (with positioner) ③ Emergency open valve or pipe dead end valve ④ Air or Gas

■ 704G-7F

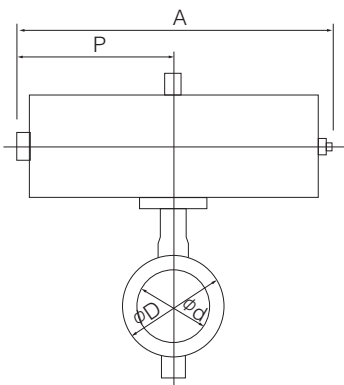

■ 704G-7G

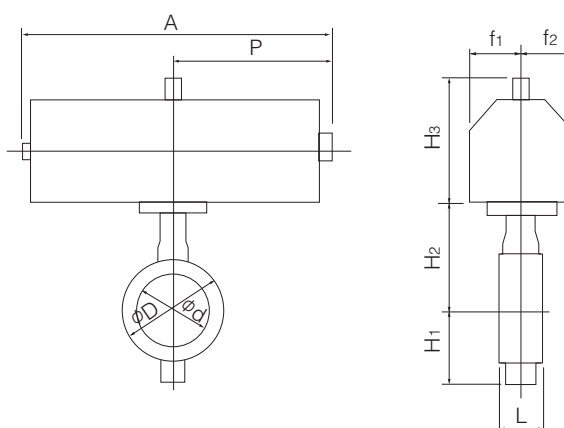

■ 7F Installation direction

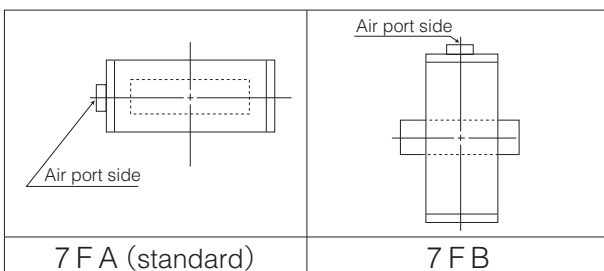

■ 7G Installation direction

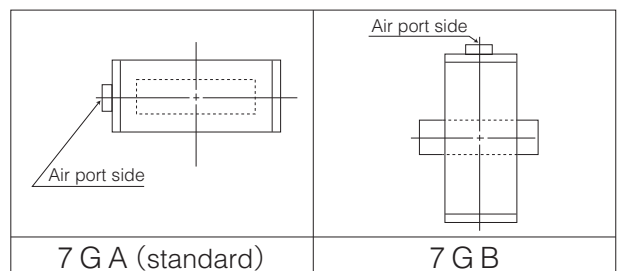

Butterfly Valve
TRITEC
TT2
334A
344Q
302A/303Q
304A/304Q
304YA
302Y/304Y
304M (HLV)
507V/508V
DTM
846T/847T/847Q
841T/842T
700Z
700G/704G/705G
72WG/72SG/72LG
731P/732P/732Q/752W
731R
700E/700K/700S
704G/722F/720F
227P
907T/908H (MKT)
903L/901C/905C (Bata-check)

704G (Full lugged)

Single-acting pneumatic cylinder type 704G-3U (Air to open: 200mm to 600mm) / 704G-3K (Air to close: 200mm to 600mm)

Standard

Nominal size		Dimension (mm)											Cylinder type	Approx. Mass (kg)
mm	inch	ϕd	ϕD		L	H ₁	H ₂	H ₃	A	P	f ₁	f ₂		
			JIS5K	JIS10K										
250	10	253	402	402	68	215	280	307	945	585	70	165	TG-10S	88
300	12	302	472	438	78	253	312	307	1080	720	94	206	TG-12S	145 (143)
350	14	337	533	505	78	276	348	307	1080	720	94	206	TG-12S	167
400	16	394	597	597	102	338	383	340	1255	865	131	257	TG-14S	305
450	18	441	634	626	114	368	413	340	1255	865	131	257	TG-14S	330 (333)
500	20	492	696	696	127	403	453	474	1655	1095	164	348	TG-20S	590
600	24	584	820	795	154	458	528	474	1655	1095	164	348	TG-20S	686 (680)

Heavy duty

Nominal size		Dimension (mm)											Cylinder type	Approx. Mass (kg)
mm	inch	ϕd	ϕD		L	H ₁	H ₂	H ₃	A	P	f ₁	f ₂		
			JIS5K	JIS10K										
200	8	199	334	329	60	176	227	307	945	585	70	165	TG-10S	75 (77)
250	10	253	402	402	68	215	280	307	1080	720	94	206	TG-12S	133
300	12	302	472	438	78	253	312	307	1080	720	94	206	TG-12S	145 (143)
350	14	337	533	505	78	276	348	340	1255	865	131	257	TG-14S	267 (267)
400	16	394	597	597	102	338	383	340	1255	865	131	257	TG-14S	305
450	18	441	634	626	114	368	413	474	1655	1095	164	348	TG-20S	543 (546)
500	20	492	696	696	127	403	453	474	1655	1095	164	348	TG-20S	590
600	24	584	820	795	154	458	528	474	1655	1095	164	348	TG-20S	686 (680)

Remark: Value in brackets is for JIS 10K flanges.

Selection criteria	Standard	Select when none of the following heavy duty items apply.
	Heavy duty	Select when any of the following items apply. ① Powder or high viscosity fluid (crude oil, etc.) ② Control specification (with positioner) ③ Emergency open valve or pipe dead end valve ④ Air or Gas

704G-3U

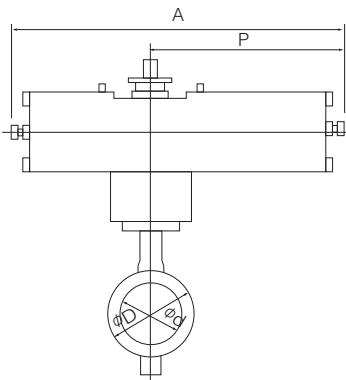

704G-3K

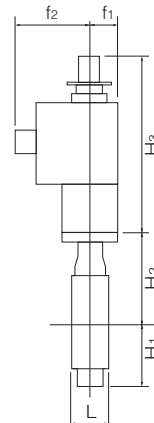
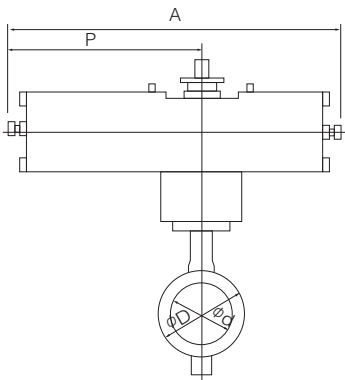

3U Installation direction

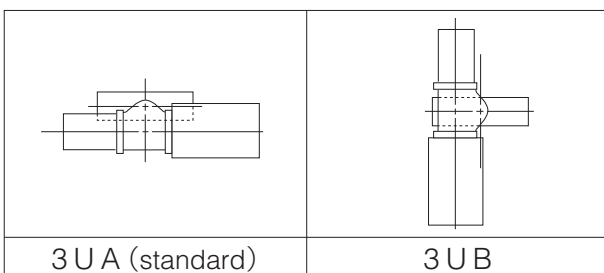

3K Installation direction

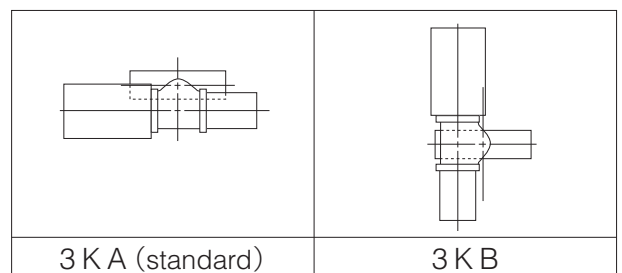

Single phase electric motor type 704G-4I (50mm to 500mm)

Nominal size		Dimension (mm)											Motor type	Approx. Mass (kg)
mm	inch	ϕd	ϕD		L	H ₁	H ₂	H ₃	A	P	F	K		
			JIS5K	JIS10K										
50	2	56	90	90	43	85	138	120	161	84	58	45	4I-00	5.0
								150	202	100	85	54	4I-0	6.7
65	2 1/2	69	115	115	46	94	151	150	202	100	85	54	4I-0	7.7 (9)
80	3	84	126	190	46	109	156	150	202	100	85	54	4I-0	8.2
100	4	104	223	223	52	117	167	165	252	138	126	65	4I-1	13.1
125	5	130	250	250	56	143	191	198	310	167	154	85	4I-2	20.0
150	6	153.5	276	276	56	164	202	198	310	167	154	85	4I-2	21.6
200	8	199	334	329	60	176	227	198	310	167	154	85	4I-2.5	26.0
250	10	253	402	402	68	215	280	198	310	167	154	85	4I-2.5	27.5
300	12	302	472	438	78	253	312	230	388	223	246	136	4I-3	62
350	14	337	533	505	78	276	348	230	388	223	246	136	4I-3	89
400	16	394	597	597	102	338	383	230	388	223	246	136	4I-3	127
								255	388	223	246	136	4I-4	136
450	18	441	634	626	114	368	413	230	388	223	246	136	4I-4	157
500	20	492	696	696	127	403	453	230	388	223	246	136	4I-4	199

Note 1: For nominal size 50 mm (for control), the 4I-0 type should be selected. (The 4I-00 type is only designed for ON-OFF operation.)

Remark: Value in brackets is for JIS 10K flanges.

Remark: For 300mm with the accessories below, type 4I-4 should be selected.

- Micom unit
- Servo unit
- Speed control unit
- Potentiometer

704G-4I

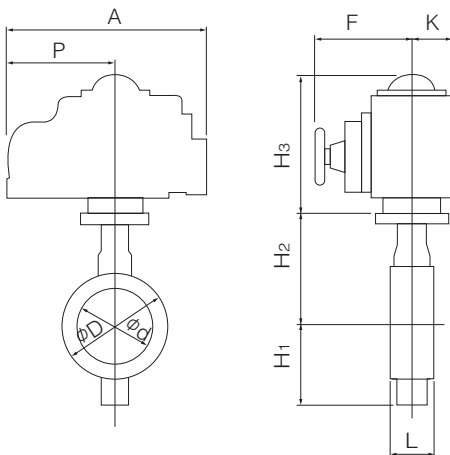

4I Installation direction

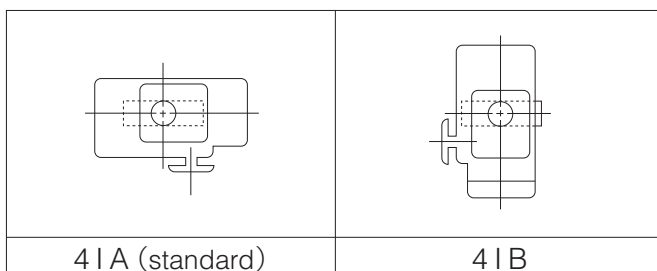

Butterfly Valve
TRITEC
TT2
334A
344Q
302A/303Q
304A/304Q
304YA
302Y/304Y
304M (HLV)
507V/508V
DTM
846T/847T/847Q
841T/842T
700Z
700G/704G/705G
72WG/72SG/72LG
731P/732P/732Q/752W
731R
700E/700K/700S
704G/722F/720F
227P
907T/908H (MKT)
903L/901C/905C (Bata-check)

Three phase motor actuator type 704G-4J (50mm to 300mm)

Nominal size		Dimension (mm)												Motor type	Approx. Mass (kg)
mm	inch	ϕd	ϕD		L	H ₁	H ₂	H ₃	H ₄	A	P	F	K		
			JIS5K	JIS10K											
50	2	56	90	90	43	85	138	218	3.2	353	167	272	104	SRJ-010	15.2
65	2 1/2	69	115	115	46	94	151	218	3.2	353	167	272	104	SRJ-010	16.5 (17.8)
80	3	84	126	190	46	109	156	218	3.2	353	167	272	104	SRJ-010	17.8
100	4	104	223	223	52	117	167	218	3.2	353	167	272	104	SRJ-010	19.7
125	5	130	250	250	56	143	191	218	15	353	167	272	104	SRJ-020	21.8
150	6	153.5	276	276	56	164	202	218	15	353	167	272	104	SRJ-020	23.4
200	8	199	334	329	60	176	227	235	3.2	393	191	316	130	SRJ-060	38
250	10	253	402	402	68	215	280	235	3.2	393	191	316	130	SRJ-060	50
300	12	302	472	438	78	253	312	235	20	393	191	316	130	SRJ-060	61

Remark: Value in brackets is for JIS 10K flanges.

704G-4J

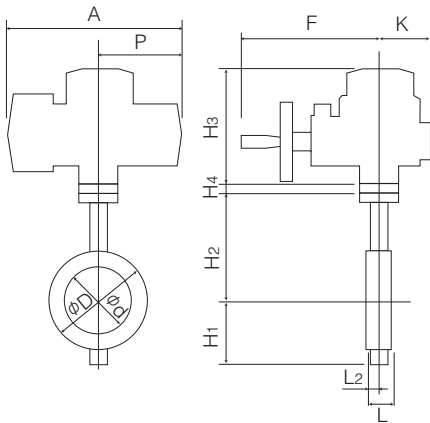

4J Installation direction

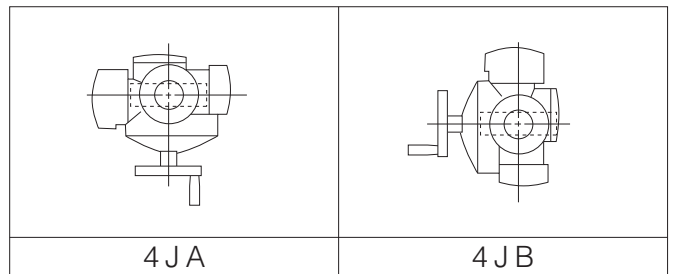

Three phase motor actuator type 704G-4L (350mm to 600mm)

Nominal size		Dimension (mm)												Motor type	Approx. Mass (kg)
mm	inch	ϕd	ϕD		L	H ₁	H ₂	H ₃	E	K	F	M	P		
			JIS5K	JIS10K											
350	14	337	533	505	78	276	348	487	117	164	533	364	230	LTKD-01 0.2kW /MGH-3	209
400	16	394	597	597	102	338	383	487	117	164	533	364	230	LTKD-01 0.2kW /MGH-3	244
450	18	441	634	626	114	368	413	487	117	164	533	357	230	LTKD-01 0.4kW /MGH-3	264
500	20	492	696	696	127	403	453	487	117	164	533	357	230	LTKD-01 0.4kW /MGH-3	291
600	24	584	820	795	154	458	528	590	140	198	637	415	375	LTKD-05 0.75kW /MGH-4	504 (498)

Remark: Value in brackets is for JIS 10K flanges.

■704G-4L

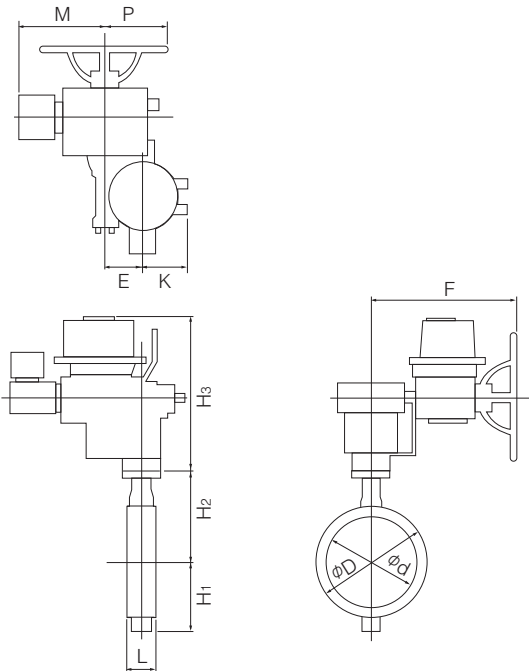

■4L Installation direction

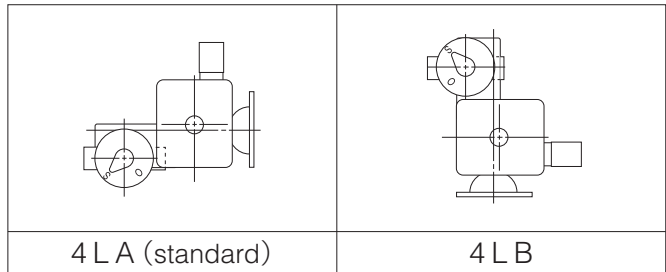

Butterfly Valve
TRITEC
TT2
334A
344Q
302A/303Q
304A/304Q
304YA
302Y/304Y
304M (HLV)
507V/508V
DTM
846T/847T/847Q
841T/842T
700Z
700G/704G/705G
72WG/72SG/72LG
731P/732P/732Q/752W
731R
700E/700K/700S
704G/722F/720F
227P
907T/908H (MKT)
903L/901C/905C (Bata-check)

Lock lever type 705G-1T (40mm to 200mm)

Nominal size		Dimension (mm)							Lever type	Approx. Mass (kg)
mm	inch	ϕd	ϕD	L	H ₁	H ₂	H ₃	W		
40	1 1/2	45	80	35	61	132	66	200	1T-1	2.6
50	2	56	90	43	85	138	66	200	1T-1	3.1
65	2 1/2	69	115	46	94	151	66	200	1T-1	4.1
80	3	84	126	46	109	156	66	200	1T-1	4.6
100	4	104	146	52	117	167	66	200	1T-1	5.6
125	5	130	181	56	143	191	92	300	1T-2	9.3
150	6	153	211	56	164	202	92	300	1T-2	12.3
200	8	199.0	256	60	186	227	97	350	1T-3	16.7

705G-1T

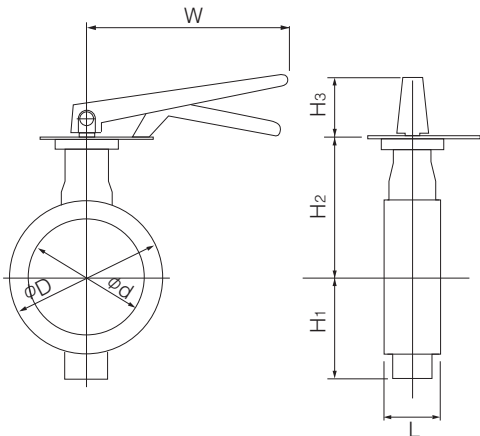

1T Installation direction

1TSL (standard)	1TLR	1TRS	1TRR
1TXS	1TXR	1TVS	1TVR

Worm gear type 705G-2U (40mm to 600mm)

Nominal size		Dimension (mm)										Gear type	Approx. Mass (kg)
mm	inch	ϕd	ϕD	L	H ₁	H ₂	H ₃	E	K	F	W		
40	1 1/2	45	80	35	61	132	29.5	36	46	160	100	2U-0	4.3
50	2	56	90	43	85	138	29.5	36	46	160	100	2U-0	4.8
65	2 1/2	69	115	46	94	151	29.5	36	46	160	100	2U-0	5.8
80	3	84	126	46	109	156	29.5	36	46	160	100	2U-1	6.3
100	4	104	146	52	117	167	29.5	36	46	160	100	2U-1	7.3
125	5	130	181	56	143	191	34.5	44	53	173.5	160	2U-2	12.2
150	6	153.5	211	56	164	202	34.5	44	53	173.5	160	2U-2	16
200	8	199	256	60	186	227	41.5	67	75	198	200	2U-3	23
250	10	253	322	68	215	280	41.5	67	75	198	200	2U-3	32
300	12	302	367	78	253	312	48	87.5	90	222.5	200	2U-4	45
350	14	337	410	78	276	348	48	87.5	90	222.5	280	2U-4	63
400	16	394	467	102	338	383	50	90	105	266	280	2U-5	91
450	18	441	525	114	368	413	50	90	105	266	280	2U-5	115
500	20	492	580	127	403	453	50	90	105	266	280	2U-5	145
550	22	524.2	633	150	416	460	61	113	140	352	400	2U-6	210
600	24	584	682	154	458	528	61	113	140	352	400	2U-6	225

705G-2U

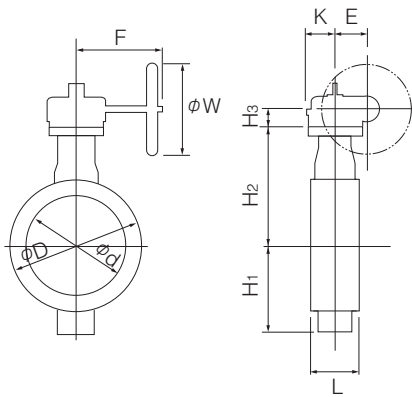

2U Installation direction

2UA (standard)	2UAR	2UB	2UBR

Butterfly Valve

TRITEC

TT2

334A

344Q

302A/303Q

304A/304Q

304YA

302Y/304Y

304M (HLV)

507V/508V

DTM

846T/847T/847Q

841T/842T

700Z

700G/704G/705G

72WG/72SG/72LG

731P/732P/732Q/752W

731R

700E/700K/700S

704G/722F/720F

227P

907T/908H (MKT)

903L/901C/905C (Bata-check)

Center handle type 705G-2G (40mm to 300mm) / 705G-2R (350mm to 600mm)

Nominal size		Dimension (mm)							Center handle type	Approx. Mass (kg)
mm	inch	ϕd	ϕD	L	H ₁	H ₂	H ₃	W		
40	1 1/2	45	80	35	61	132	136	100	2G-1	4.9
50	2	56	90	43	85	138	136	100	2G-1	5.4
65	2 1/2	69	115	46	94	151	136	100	2G-1	6.4
80	3	84	126	46	109	156	136	100	2G-1	6.9
100	4	104	146	52	117	167	136	100	2G-1	7.9
125	5	130	181	56	143	191	133	100	2G-2	11.8
150	6	153.5	211	56	164	202	133	100	2G-2	14.8
200	8	199	256	60	186	227	151	200	2G-3	22.1
250	10	253	322	68	215	280	151	200	2G-3	32
300	12	302	367	78	253	312	161	200	2G-4	39
350	14	337	410	78	276	348	409	355	2R-3	82
400	16	394	467	102	338	383	409	355	2R-3	105
450	18	441	525	114	368	413	409	355	2R-3	130
500	20	492	580	127	403	453	409	355	2R-3	161
550	22	524.2	633	150	416	460	498	450	2R-4	262
600	24	584	682	154	458	528	498	450	2R-4	244

705G-2G/2R

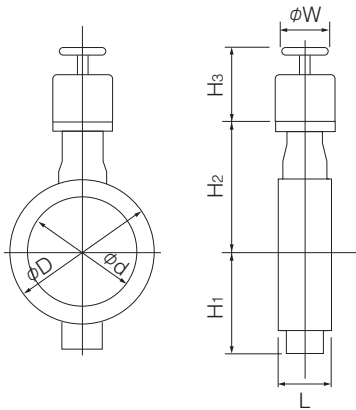

Double-acting pneumatic cylinder type 705G-7E (40mm to 350mm)

Standard

Nominal size		Dimension (mm)										Cylinder type	Approx. Mass (kg)
mm	inch	ϕd	ϕD	L	H ₁	H ₂	H ₃	A	P	f ₁	f ₂		
40	1 1/2	45	80	35	61	132	125	228	116	57	29	T35	4
50	2	56	90	43	85	138	125	228	116	57	29	T35	5
65	2 1/2	69	115	46	94	151	125	228	116	57	29	T35	6
80	3	84	126	46	109	156	168	276	142	75	47	T85	9
100	4	104	146	52	117	167	168	276	142	75	47	T85	10
125	5	130	181	56	143	191	168	276	142	75	47	T85	13
150	6	153.5	211	56	164	202	203	346	176	79	57	T200	19
200	8	199	256	60	186	227	231	423	214	91	69	T380	29
250	10	253	322	68	215	280	231	423	214	91	69	T380	38
300	12	302	367	78	253	312	269	546	270	118	85	T750	55
350	14	337	410	78	276	348	324	546	270	118	85	T750	79

Heavy duty

Nominal size		Dimension (mm)										Cylinder type	Approx. Mass (kg)
mm	inch	ϕd	ϕD	L	H ₁	H ₂	H ₃	A	P	f ₁	f ₂		
40	1 1/2	45	80	35	61	132	125	228	116	57	29	T35	4
50	2	56	90	43	85	138	125	228	116	57	29	T35	5
65	2 1/2	69	115	46	94	151	125	228	116	57	29	T35	6
80	3	84	126	46	109	156	168	276	142	75	47	T85	9
100	4	104	146	52	117	167	203	346	176	79	57	T200	13
125	5	130	181	56	143	191	203	346	176	79	57	T200	16
150	6	153.5	211	56	164	202	203	346	176	79	57	T200	19
200	8	199	256	60	186	227	231	423	214	91	69	T380	29
250	10	253	322	68	215	280	231	423	214	91	69	T380	38
300	12	302	367	78	253	312	269	546	270	118	85	T750	55

Butterfly Valve
TRITEC
TT2
334A
344Q
302A/303Q
304A/304Q
304YA
302Y/304Y
304M (HLV)
507V/508V
DTM
846T/847T/847Q
841T/842T
700Z
700G/704G/705G
72WG/72SG/72LG
731P/732P/732Q/752W
731R
700E/700K/700S
704G/722F/720F
227P
907T/908H (MKT)
903L/901C/905C (Bata-check)

Selection criteria	Standard	Select when none of the following heavy duty items apply.
	Heavy duty	Select when any of the following items apply. ① Powder or high viscosity fluid (crude oil, etc.) ② Control specification (with positioner) ③ Emergency open valve or pipe dead end valve ④ Air or Gas

705G-7E

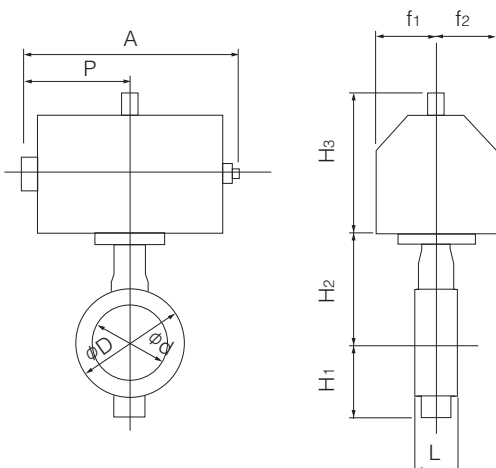

7E Installation direction

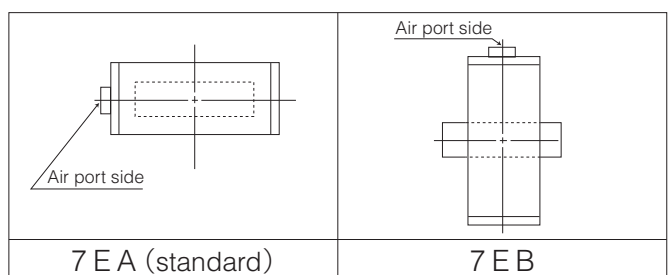

Double-acting pneumatic cylinder type 705G-3A (400mm to 600mm)

Standard

Nominal size		Dimension (mm)										Cylinder type	Approx. Mass (kg)
mm	inch	ϕd	ϕD	L	H ₁	H ₂	H ₃	A	P	f ₁	f ₂		
400	16	394	467	102	338	383	364	754	381	100	164	TGA-125	110
450	18	441	525	114	368	413	412	840	432	100	180	TGA-140	150
500	20	492	580	127	403	453	465	954	483	130	202	TGA-160	220
550	22	524.2	633	150	416	460	465	954	483	130	203	TGA-160	287
600	24	584	682	154	458	528	478	1069	543	130	218	TGA-180	330

Heavy duty

Nominal size		Dimension (mm)										Cylinder type	Approx. Mass (kg)
mm	inch	ϕd	ϕD	L	H ₁	H ₂	H ₃	A	P	f ₁	f ₂		
350	14	337	410	78	276	348	364	754	381	100	164	TGA-125	85
400	16	394	467	102	338	383	412	840	432	100	180	TGA-140	124
450	18	441	525	114	368	413	465	854	483	130	202	TGA-160	200
500	20	492	580	127	403	453	465	854	483	130	202	TGA-160	220
550	24	524.2	633	150	416	460	478	1069	543	130	221	TGA-200	328
600	24	584	682	154	458	528	525	1175	599	160	253	TGA-200	390

705G-3A

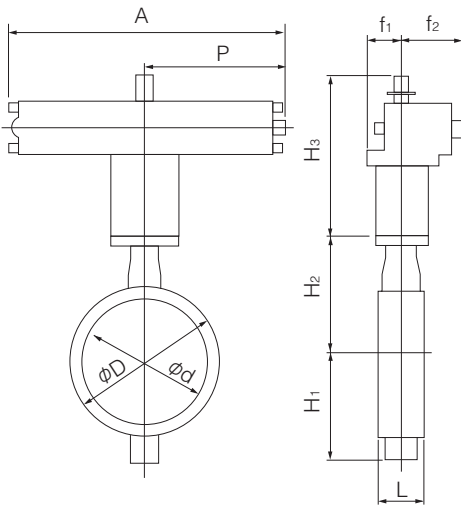

Selection criteria	Standard	Select when none of the following heavy duty items apply.
	Heavy duty	Select when any of the following items apply. ① Powder or high viscosity fluid (crude oil, etc.) ② Control specification (with positioner) ③ Emergency open valve or pipe dead end valve ④ Air or Gas

3A Installation direction

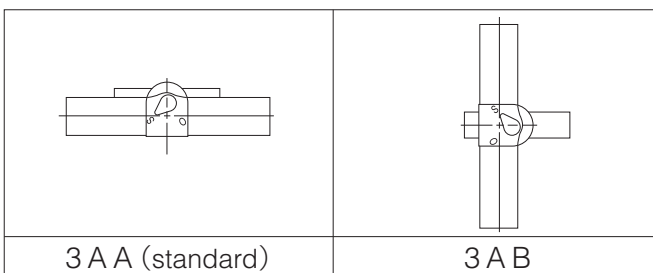

Single-acting pneumatic cylinder type 705G-7G (Air to open: 40mm to 250mm) / 705G-7F (Air to close: 40mm to 250mm)

■ Standard

Nominal size		Dimension (mm)										Cylinder type	Approx. Mass (kg)
mm	inch	ϕd	ϕD	L	H ₁	H ₂	H ₃	A	P	f ₁	f ₂		
40	1 1/2	45	80	35	61	132	168	364	183	75	47	T85S	8
50	2	56	90	43	85	138	168	364	183	75	47	T85S	9
65	2 1/2	69	115	46	94	151	203	449	226	79	57	T200S	14
80	3	84	126	46	109	156	203	449	226	79	57	T200S	15
100	4	104	146	52	117	167	203	449	226	79	57	T200S	16
125	5	130	181	56	143	191	231	550	276	91	69	T380S	27
150	6	153.5	211	56	164	202	231	550	276	91	69	T380S	30
200	8	199	256	60	186	227	269	723	360	118	85	T750S	48
250	10	253	322	68	215	280	269	723	360	118	85	T750S	57

■ Heavy duty

Nominal size		Dimension (mm)										Cylinder type	Approx. Mass (kg)
mm	inch	ϕd	ϕD	L	H ₁	H ₂	H ₃	A	P	f ₁	f ₂		
40	1 1/2	45	80	35	61	132	168	364	183	75	47	T85S	8
50	2	56	90	43	85	138	168	364	183	75	47	T85S	9
65	2 1/2	69	115	46	94	151	203	449	226	79	57	T200S	14
80	3	84	126	46	109	156	203	449	226	79	57	T200S	15
100	4	104	146	52	117	167	231	550	276	91	69	T380S	24
125	5	130	181	56	143	191	231	550	276	91	69	T380S	27
150	6	153.5	211	56	164	202	269	723	360	118	85	T750S	44

Selection criteria	Standard	Select when none of the following heavy duty items apply.
	Heavy duty	Select when any of the following items apply. ① Powder or high viscosity fluid (crude oil, etc.) ② Control specification (with positioner) ③ Emergency open valve or pipe dead end valve ④ Air or Gas

■ 705G-7F

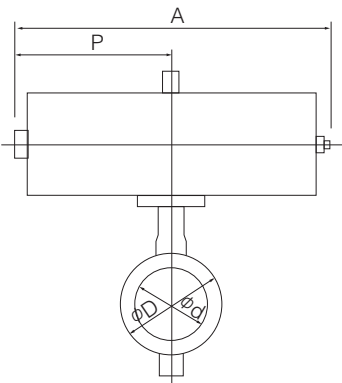

■ 705G-7G

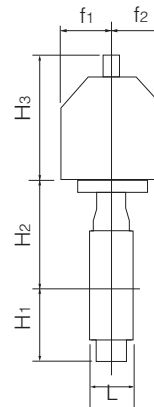
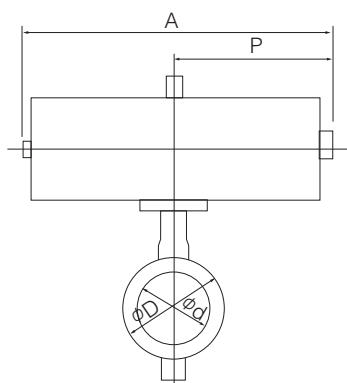

■ 7F Installation direction

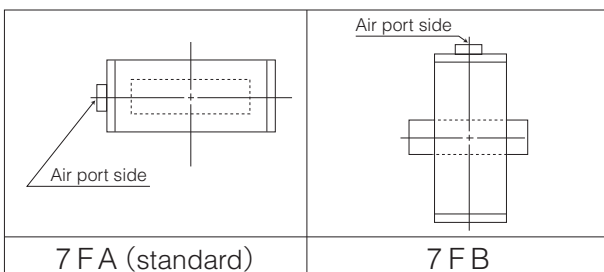

■ 7G Installation direction

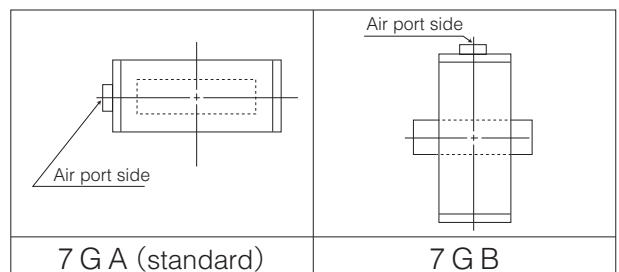

Butterfly Valve
TRITEC
TT2
334A
344Q
302A/303Q
304A/304Q
304YA
302Y/304Y
304M (HLV)
507V/508V
DTM
846T/847T/847Q
841T/842T
700Z
700G/704G/705G
72WG/72SG/72LG
731P/732P/732Q/752W
731R
700E/700K/700S
704G/722F/720F
227P
907T/908H (MKT)
903L/901C/905C (Bata-check)

Single-acting pneumatic cylinder type 705G-3U (Air to open: 200mm to 600mm) / 705G-3K (Air to close: 200mm to 600mm)

Standard

Nominal size		Dimension (mm)										Cylinder type	Approx. Mass (kg)
mm	inch	ϕd	ϕD	L	H ₁	H ₂	H ₃	A	P	f ₁	f ₂		
250	10	253	322	68	215	280	307	945	585	70	165	TG-10S	87
300	12	302	367	78	253	312	307	1080	720	94	206	TG-12S	132
350	14	337	410	78	276	348	307	1080	720	94	206	TG-12S	148
400	16	394	467	102	338	383	340	1255	865	131	257	TG-14S	270
450	18	441	525	114	368	413	340	1255	865	131	257	TG-14S	294
500	20	492	580	127	403	453	474	1655	1095	164	348	TG-20S	538
550	22	524.2	633	150	416	460	474	1655	1095	164	348	TG-20S	594
600	24	584	682	154	458	528	474	1655	1095	164	348	TG-20S	602

Heavy duty

Nominal size		Dimension (mm)										Cylinder type	Approx. Mass (kg)
mm	inch	ϕd	ϕD	L	H ₁	H ₂	H ₃	A	P	f ₁	f ₂		
200	8	199	256	60	186	227	307	945	585	70	165	TG-10S	77
250	10	253	322	68	215	280	307	1080	720	94	206	TG-12S	125
300	12	302	367	78	253	312	307	1080	720	94	206	TG-12S	132
350	14	337	410	78	276	348	340	1255	865	131	257	TG-14S	244
400	16	394	467	102	338	383	340	1255	865	131	257	TG-14S	270
450	18	441	525	114	368	413	474	1655	1095	164	348	TG-20S	507
500	20	492	580	127	403	453	474	1655	1095	164	348	TG-20S	538
550	22	524.2	633	150	416	460	474	1655	1095	164	348	TG-20S	594
600	24	584	682	154	458	528	474	1655	1095	164	348	TG-20S	602

Selection criteria	Standard	Select when none of the following heavy duty items apply.
	Heavy duty	Select when any of the following items apply. ① Powder or high viscosity fluid (crude oil, etc.) ② Control specification (with positioner) ③ Emergency open valve or pipe dead end valve ④ Air or Gas

705G-3U

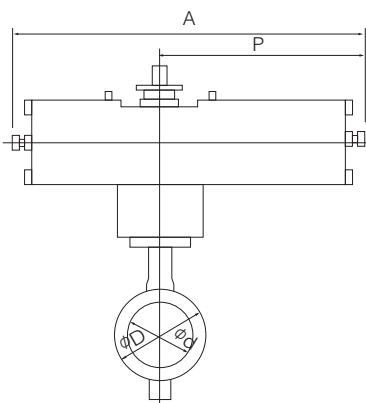

705G-3K

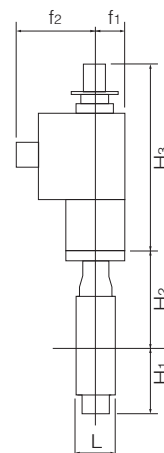
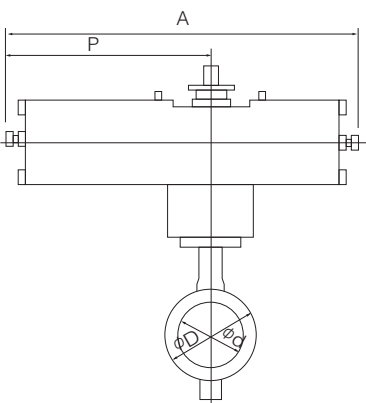

3U Installation direction

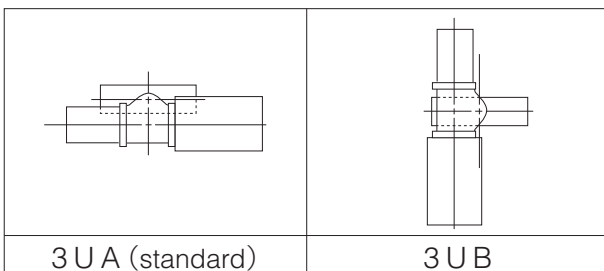

3K Installation direction

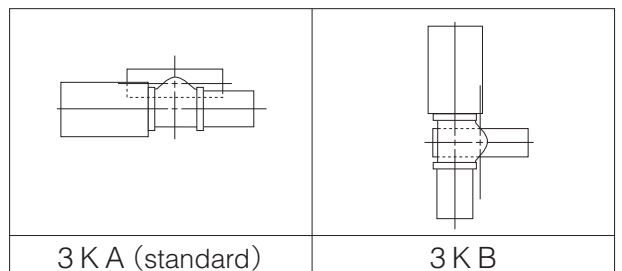

Single phase electric motor type 705G-4I (40mm to 500mm)

Nominal size		Dimension (mm)										Motor type	Approx. Mass (kg)
mm	inch	ϕd	ϕD	L	H ₁	H ₂	H ₃	A	P	F	K		
40	1 1/2	45	80	35	61	132	120	161	84	58	45	4 I-00	4.8
							176	202	100	85	54	4 I-0	6.2
50	2	56	90	43	85	138	120	161	84	58	45	4 I-00	5.3
							176	202	100	85	54	4 I-0	7.0
65	2 1/2	69	115	46	94	151	150	202	100	85	54	4 I-0	8.0
80	3	84	126	46	109	156	150	202	100	85	54	4 I-0	8.5
100	4	104	146	52	117	167	165	252	138	126	65	4 I-1	11.4
125	5	130	181	56	143	191	198	310	167	154	85	4 I-2	19.2
150	6	153.5	211	56	164	202	198	310	167	154	85	4 I-2	22.2
200	8	199	256	60	186	227	198	310	167	154	85	4 I-2.5	26.2
250	10	253	322	68	215	280	198	310	167	154	85	4 I-2.5	37
300	12	302	367	78	253	312	230	388	223	246	136	4 I-3	55
350	14	337	410	78	276	348	230	388	223	246	136	4 I-3	70
400	16	394	467	102	338	383	230	388	223	246	136	4 I-3	95
							255	388	223	246	136	4 I-4	101
450	18	441	525	114	368	413	230	388	223	246	136	4 I-4	125
500	20	492	580	127	403	453	230	388	223	246	136	4 I-4	156

Note 1: For nominal size 40mm and 50 mm type (for control), the 4I-0 type should be selected. (The 4I-00 type is only designed for ON-OFF operation.)

Remark: For 400mm type with the accessories below, type 4I-4 should be selected.

- Micom unit
- Servo unit
- Speed control unit
- Potentiometer

705G-4 I

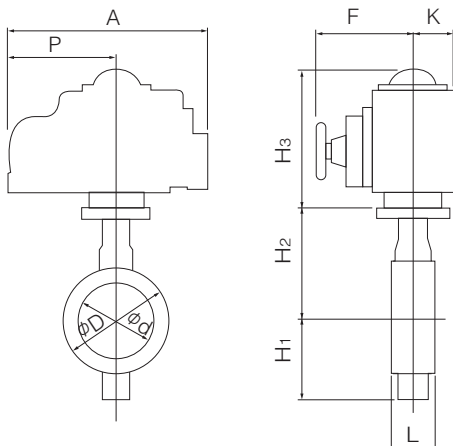

4 I Installation direction

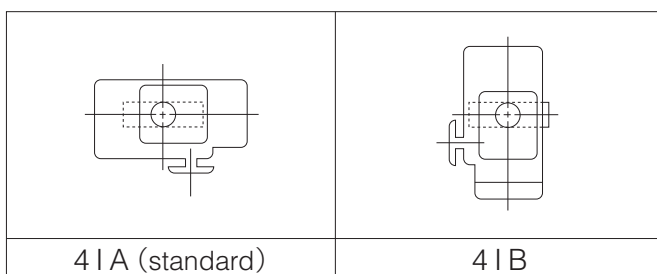

Butterfly Valve
TRITEC
TT2
334A
344Q
302A/303Q
304A/304Q
304YA
302Y/304Y
304M (HLV)
507V/508V
DTM
846T/847T/847Q
841T/842T
700Z
700G/704G/705G
72WG/72SG/72LG
731P/732P/732Q/752W
731R
700E/700K/700S
704G/722F/720F
227P
907T/908H (MKT)
903L/901C/905C (Bata-check)

Three phase motor actuator type 705G-4J(40mm to 300mm)

Nominal size		Dimension (mm)											Motor type	Approx. Mass (kg)
mm	inch	φd	φD	L	H ₁	H ₂	H ₃	H ₄	A	P	F	K		
40	1 1/2	45	80	35	61	132	218	3.2	353	167	286	104	SRJ-010	15.7
50	2	56	90	43	85	138	218	3.2	353	167	272	104	SRJ-010	16.2
65	2 1/2	69	115	46	94	151	218	3.2	353	167	272	104	SRJ-010	17.2
80	3	84	126	46	109	156	218	3.2	353	167	272	104	SRJ-010	17.7
100	4	104	146	52	117	167	218	3.2	353	167	272	104	SRJ-010	18.5
125	5	130	181	56	143	191	218	15	353	167	272	104	SRJ-020	22.2
150	6	153.5	211	56	164	202	218	15	353	167	272	104	SRJ-020	25
200	8	199	256	60	186	227	235	3.2	393	191	316	130	SRJ-060	43
250	10	253	322	68	215	280	235	3.2	393	191	316	130	SRJ-060	56
300	12	302	367	78	253	312	235	20	393	191	316	130	SRJ-060	67

705G-4J

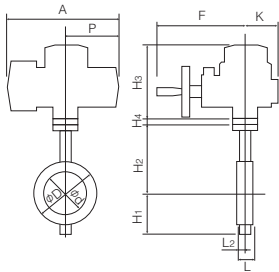

4J Installation direction

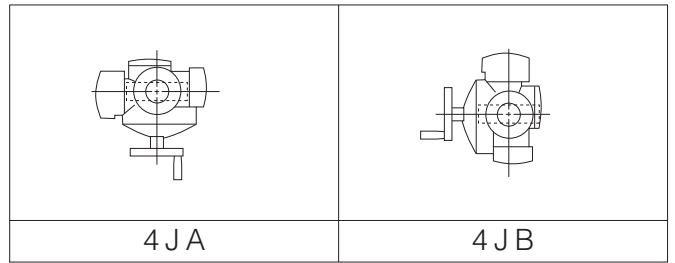

Three phase motor actuator type 705G-4L(350mm to 600mm)

Nominal size		Dimension (mm)											Motor type	Approx. Mass (kg)
mm	inch	φd	φD	L	H ₁	H ₂	H ₃	E	K	F	M	P		
350	14	337	410	78	276	348	487	117	164	533	364	230	LTKD-01 0.2kW /MGH-3	148
400	16	394	467	102	338	383	487	117	164	533	364	230	LTKD-01 0.2kW /MGH-3	173
450	18	441	525	114	368	413	487	117	164	533	357	230	LTKD-01 0.4kW /MGH-3	201
500	20	492	580	127	403	453	487	117	164	533	357	230	LTKD-01 0.4kW /MGH-3	232
550	22	524.2	633	150	416	460	558	140	198	594	375	230	LTKD-02 0.75kW /MGH-4	325
600	24	584	682	154	458	528	590	140	198	637	415	360	LTKD-05 0.75kW /MGH-4	398

705G-4L

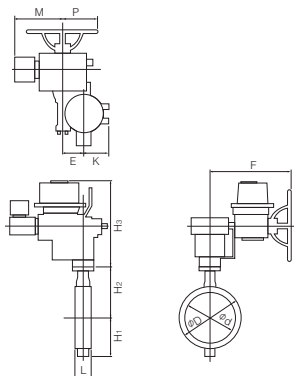

4L Installation direction

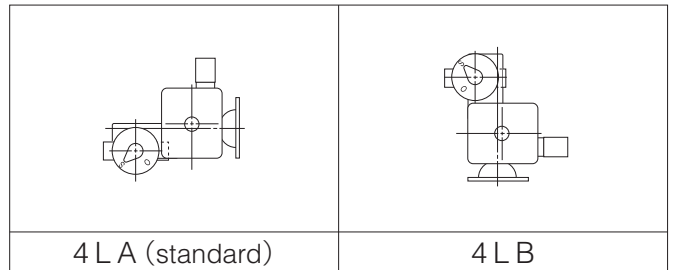

700G/704G/705G Cv value/pressure loss coefficient

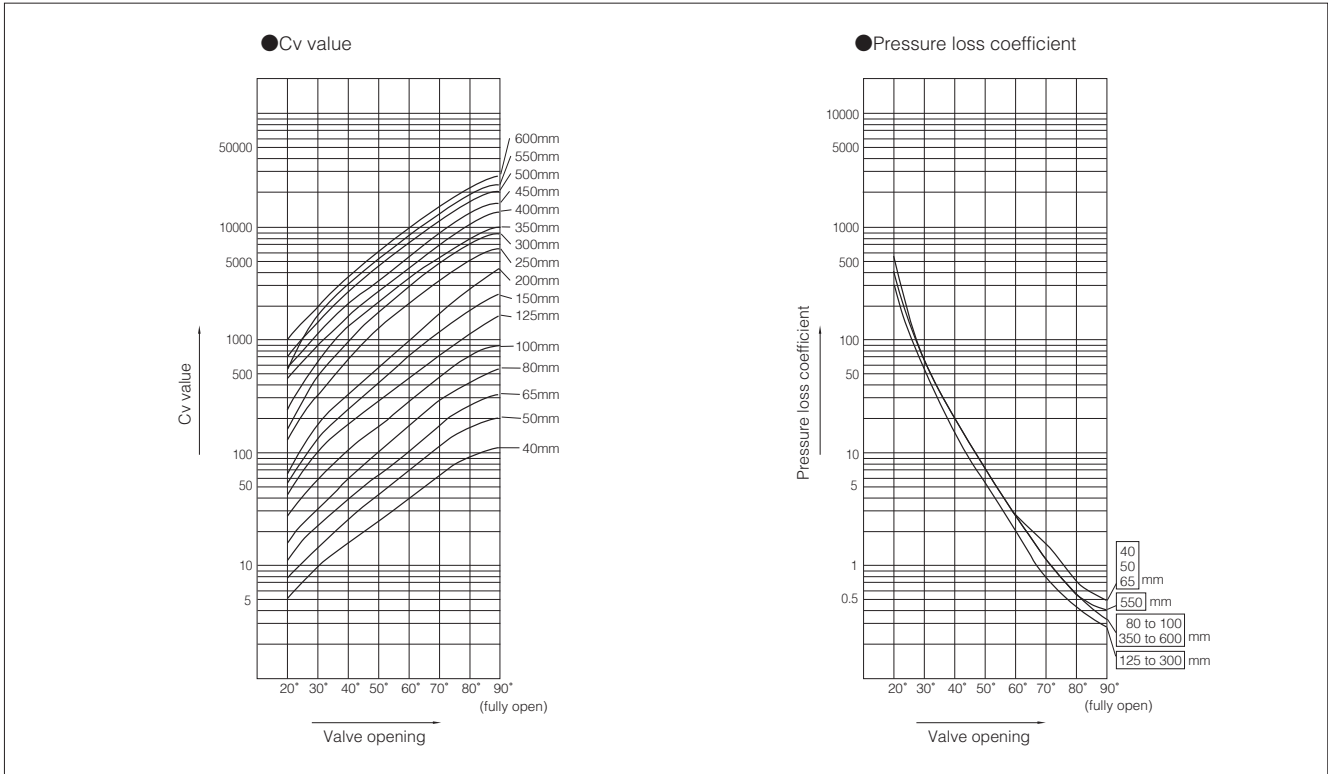

- Butterfly Valve
- TRITEC**
- TT2**
- 334A**
- 344Q**
- 302A/303Q**
- 304A/304Q**
- 304YA**
- 302Y/304Y**
- 304M (HLV)**
- 507V/508V**
- DTM**
- 846T/847T/847Q**
- 841T/842T**
- 700Z**
- 700G/704G/705G**
- 72WG/72SG/72LG**
- 731P/732P/732Q/752W**
- 731R**
- 700E/700K/700S**
- 704G/722F/720F**
- 227P**
- 907T/908H (MKT)**
- 903L/901C/905C (Bata-check)**

700G/704G/705G Cv value

Nominal size		Valve opening							
mm	inch	20°	30°	40°	50°	60°	70°	80°	90°
40	1 1/2	5	9	16	25	39	61	95	121
50	2	8	15	25	40	64	103	160	200
65	2 1/2	12	25	41	64	102	162	260	320
80	3	15	33	57	95	163	271	450	580
100	4	27	58	100	162	269	444	749	880
125	5	45	109	189	295	453	719	1144	1590
150	6	60	148	262	423	685	1147	1897	2800
200	8	67	188	347	576	969	1698	2902	4300
250	10	130	351	675	1225	2125	3375	5091	6200
300	12	194	487	972	1764	3011	4966	7412	8900
350	14	232	662	1350	2030	3294	5167	7832	9620
400	16	468	964	1648	2724	4529	6815	10553	12700
450	18	583	1202	2068	3448	5692	8384	13116	15500
500	20	758	1555	2656	4379	7214	10845	17100	19800
550	22	571	1765	3234	5141	7833	12066	17999	22500
600	24	1037	2141	3681	6129	10106	14911	22827	27300

700G / 704G / 705G Pressure Loss Coefficient

Nominal size		Valve opening							
mm	inch	20°	30°	40°	50°	60°	70°	80°	90°
40	1 1/2	264	72	26	10	4	2	1	0.4
50	2	257	68	25	10	4	2	1	0.4
65	2 1/2	310	75	28	11	4	2	1	0.4
80	3	394	83	27	10	3	1	0.4	0.2
100	4	350	78	26	10	4	1	0.4	0.3
125	5	316	53	18	7	3	1	0.4	0.2
150	6	348	57	18	7	3	1	0.3	0.1
200	8	849	106	31	11	4	1	0.4	0.2
250	10	528	72	20	6	2	1	0.3	0.2
300	12	488	78	20	6	2	1	0.3	0.2
350	14	531	65	16	7	3	1	0.4	0.3
400	16	227	54	18	7	2	1	0.4	0.3
450	18	239	56	19	7	3	1	0.4	0.3
500	20	218	52	18	7	2	1	0.4	0.3
550	22	571	60	18	7	3	1	0.6	0.4
600	24	247	58	20	7	3	1	1	0.3

700G Flange accommodation

Nominal size		JIS		ASME		BS4504		DIN		BS10
mm	inch	5K	10K	Class 125	Class 150	PN10	PN16	NP10	NP16	Table E
40	1 1/2	○	○	○	○	○	○	○	○	○
50	2	○	○	○	○	○	○	○	○	○
65	2 1/2	○	○	○	○	○	○	○	○	△
80	3	○	○	◎	◎	◎	◎	◎	◎	○
100	4	○	○	◎	◎	◎	◎	◎	◎	○
125	5	○	○	◎	◎	◎	◎	◎	◎	○
150	6	○	○	○	○	○	○	○	○	○
200	8	○	○	◎	◎	◎	◎	◎	◎	○
250	10	○	○	○	○	○	○	○	○	○
300	12	○	○	◎	◎	◎	◎	◎	◎	○
350	14	○	○	×	×	×	×	×	×	×
400	16	○	○	×	×	×	×	×	×	×
450	18	○	○	×	×	×	×	×	×	×
500	20	○	○	×	×	×	×	×	×	×
550	22	T	T	×	×	×	×	×	×	×
600	24	T	T	△	△	△	△	△	△	△

○ : Can be used without flange drilling.
 ◎ : Can be used without flange drilling. (Use ASME body.)
 △ : With additional flange drilling.
 T : With flange tapping.
 × : Not applicable.

704G Flange accommodation

Nominal size		JIS		ASME		BS4504		DIN		BS10
mm	inch	5K	10K	Class 125	Class 150	PN10	PN16	NP10	NP16	Table E
50	2	○D/T	○D/T	○D/T	○D/T	○D/T	○D/T	○D/T	○D/T	○D/T
65	2 1/2	○D/T	○D/T	○D/T	○D/T	○D/T	○D/T	○D/T	○D/T	○D/T
80	3	◎D/T	○D/T	◎D/T	◎D/T	○D/T	○D/T	○D/T	○D/T	◎D/T
100	4	○D/T	○D/T	○D/T	○D/T	○D/T	○D/T	○D/T	○D/T	○D/T
125	5	○D/T	○D/T	○D/T	○D/T	○D/T	○D/T	○D/T	○D/T	○D/T
150	6	○D/T	○D/T	○D/T	○D/T	○D/T	○D/T	○D/T	○D/T	○D/T
200	8	◎D/T	○D/T	◎D/T	◎D/T	◎D/T	○D/T	◎D/T	○D/T	◎D/T
250	10	○D/T	○D/T	○D/T	○D/T	○D/T	○D/T	○D/T	○D/T	○D/T
300	12	◎D/T	○D/T	◎D/T	◎D/T	◎D/T	◎D/T	◎D/T	◎D/T	◎D/T
350	14	◎D/T	○D/T	◎D/T	◎D/T	○D/T	○D/T	○D/T	○D/T	◎D/T
400	16	○D/T	○D/T	○D/T	○D/T	○D/T	○D/T	○D/T	○D/T	△D/T
450	18	◎D/T	○D/T	◎D/T	◎D/T	○D/T	○D/T	○D/T	○D/T	○D/T
500	20	○D/T	○D/T	○D/T	○D/T	○D/T	○D/T	○D/T	○D/T	△D/T
600	24	◎T	○T	◎T	◎T	◎T	◎T	◎T	◎T	△T

○D/T: Drilled or tapped hole
 ◎D/T: Drilled or tapped hole (JIS 5K / ASME body used)
 △D/T: Drilled or tapped hole (DIN body used)
 ○T: Tapped hole only
 ◎T: Tapped hole only (JIS 5K / ASME body used)
 △T: Tapped hole only (DIN body used)
 ×: Not applicable.

705G Flange accommodation

Nominal size		JIS		ASME		BS4504		DIN		BS10
mm	inch	5K	10K	Class 125	Class 150	PN10	PN16	NP10	NP16	Table E
40	1 1/2	D/T	D/T	D/T	D/T	D/T	D/T	D/T	D/T	D/T
50	2	D/T	D/T	D/T	D/T	D/T	D/T	D/T	D/T	D/T
65	2 1/2	D/T	D/T	D/T	D/T	D/T	D/T	D/T	D/T	D/T
80	3	D/T	D/T	D/T	D/T	D/T	D/T	D/T	D/T	D/T
100	4	D/T	D/T	D/T	D/T	D/T	D/T	D/T	D/T	D/T
125	5	D/T	D/T	D/T	D/T	D/T	D/T	D/T	D/T	D/T
150	6	D/T	D/T	D/T	D/T	D/T	D/T	D/T	D/T	D/T
200	8	D/T	D/T	D/T	D/T	D/T	D/T	D/T	D/T	D/T
250	10	D/T	D/T	D/T	D/T	D/T	D/T	D/T	D/T	D/T
300	12	D/T	D/T	D/T	D/T	D/T	D/T	D/T	D/T	D/T
350	14	D/T	D/T	D/T	D/T	D/T	D/T	D/T	D/T	D/T
400	16	D/T	D/T	D/T	D/T	D/T	D/T	D/T	D/T	D/T
450	18	D/T	D/T	D/T	D/T	D/T	D/T	D/T	D/T	D/T
500	20	D/T	D/T	D/T	D/T	D/T	D/T	D/T	D/T	D/T
550	22	T	T	×	×	×	×	×	×	×
600	24	T	T	T	T	T	T	T	T	T

D/T: Drilled or tapped hole
 T: Tapped hole only
 ×: Not applicable.

Butterfly Valve
TRITEC
TT2
334A
344Q
302A/303Q
304A/304Q
304YA
302Y/304Y
304M (HLV)
507V/508V
DTM
846T/847T/847Q
841T/842T
700Z
700G/704G/705G
72WG/72SG/72LG
731P/732P/732Q/752W
731R
700E/700K/700S
704G/722F/720F
227P
907T/908H (MKT)
903L/901C/905C (Bata-check)

700G / 704G / 705G Applicable Pipe List in Case of A

Nominal size		SGP	STPY	Sch20	Sch40	VP (TS flange)	Sch10S	Sch20S	Minimum internal diameters of piping (mm)
mm	inch								
40	1 1/2	○	—	—	○	○	○	○	29
50	2	○	—	○	○	○	○	○	38
65	2 1/2	○	—	○	○	○	○	○	54
80	3	○	—	○	○	○	○	○	72
100	4	○	—	○	○	○	○	○	92
125	5	○	—	○	○	○	○	○	119
150	6	○	—	○	○	○	○	○	145
200	8	○	—	○	○	○	○	○	194
250	10	○	—	○	○	○	○	○	247
300	12	○	—	○	○	○	○	○	295
350	14	○	○	○	○	○	—	—	333
400	16	○	○	○	○	—	—	—	382
450	18	○	○	○	○	—	—	—	427
500	20	○	○	○	○	—	—	—	477
550	22	—	○	○	○	—	—	—	509
600	24	—	○	○	○	—	—	—	567

700G / 704G / 705G Applicable Pipe List in Case of B

Nominal size		SGP	STPY	Sch20	Sch40	Sch10S	Sch20S
mm	inch						
40	1 1/2	○	—	—	○	○	○
50	2	○	—	○	○	○	○
65	2 1/2	○	—	○	○	○	○
80	3	○	—	○	○	○	○
100	4	○	—	○	○	○	○
125	5	○	—	○	○	○	○
150	6	○	—	○	○	○	○
200	8	○	—	○	○	○	○
250	10	○	—	○	○	○	○
300	12	○	—	○	○	○	○
350	14	○	○	○	○	—	—
400	16	○	○	○	○	—	—
450	18	○	○	○	○	—	—
500	20	○	○	○	○	—	—
550	22	—	○	○	○	—	—
600	24	—	○	○	○	—	—

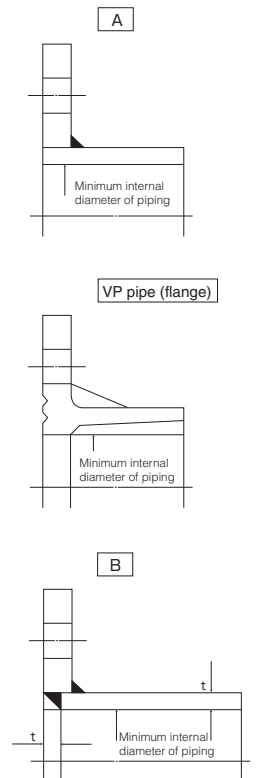

Remark 1: The symbols above mean the following.

○: Piping possible —: Not standardized

Remark 2: Butterfly valves are inserted into a pipe that was fitted with the disc when fully open.

In cases where you are using a pipe or flange that is less than the minimum inner pipe diameter, use is still possible if means are taken such as inserting a spacer between the valve and flange. For details, please consult us.

700G Piping Bolts and Nuts Sizes

■ For Hexagon Bolts and Nuts

Nominal size		JIS 5K		JIS 10K	
mm	inch	Hexagon Bolts and Nuts	Setting Bolts	Hexagon Bolts and Nuts	Setting Bolts
40	1 1/2	4-M12× 75×30	—	4-M16× 90×38	—
50	2	4-M12× 90×30	—	4-M16×100×38	—
65	2 1/2	4-M12× 90×30	—	4-M16×105×38	—
80	3	4-M16× 95×38	—	8-M16×105×38	—
100	4	8-M16×105×38	—	8-M16×110×38	—
125	5	8-M16×110×38	—	8-M20×125×46	—
150	6	8-M16×115×38	—	8-M20×130×52	—
200	8	8-M20×130×52	—	12-M20×130×52	—
250	10	12-M20×140×52	—	12-M22×150×60	—
300	12	12-M20×150×52	—	16-M22×160×60	—
350	14	12-M22×155×45	—	16-M22×160×45	—
400	16	16-M22×180×45	—	16-M24×190×45	—
450	18	16-M22×190×45	—	20-M24×205×45	—
500	20	20-M22×205×45	—	20-M24×215×45	—
550	22	16-M24×235×50	8-M24× 65×54	16-M30×255×60	8-M30× 80×66
600	24	16-M24×235×50	8-M24× 70×54	20-M30×255×60	8-M30× 75×60

■ For Long Bolts and Nuts

Nominal size		JIS 5K		JIS 10K		ASME Class 125/150	
mm	inch	Long Bolts and Nuts	Setting Bolts	Long Bolts and Nuts	Setting Bolts	Long Bolts and Nuts	Setting Bolts
40	1 1/2	4-M12× 95×25	—	4-M16×110×25	—	4-U1/2 ×110×32	—
50	2	4-M12×105×25	—	4-M16×120×30	—	4-U5/8 ×140×38	—
65	2 1/2	4-M12×110×25	—	4-M16×125×30	—	4-U5/8 ×140×38	—
80	3	4-M16×120×30	—	8-M16×125×30	—	4-U5/8 ×140×38	—
100	4	8-M16×130×30	—	8-M16×130×30	—	8-U5/8 ×150×38	—
125	5	8-M16×130×30	—	8-M20×150×40	—	8-U3/4 ×160×51	—
150	6	8-M16×140×35	—	8-M20×155×40	—	8-U3/4 ×165×51	—
200	8	8-M20×155×40	—	12-M20×165×40	—	8-U3/4 ×175×51	—
250	10	12-M20×165×40	—	12-M22×175×45	—	12-U7/8 ×195×58	—
300	12	12-M20×175×40	—	16-M22×185×45	—	12-U7/8 ×205×58	—
350	14	12-M22×185×45	—	16-M22×185×45	—	12-U1 ×225	—
400	16	16-M22×205×45	—	16-M24×220×50	—	16-U1 ×255	—
450	18	16-M22×225×45	—	20-M24×245×50	—	16-U1 1/8 ×280	—
500	20	20-M22×230×45	—	20-M24×265×50	—	20-U1 1/8 ×295	—
550	22	16-M24×265×50	8-M24× 65×54	16-M30×290×60	8-M30× 80×66	—	—
600	24	16-M24×275×50	8-M24× 70×54	20-M30×300×60	8-M30× 75×60	16-U1 1/4 ×340	8-U1 1/4×95×70

Remarks:

1. Please use a hexagon nut with 80% threading. (For ASME, use heavy nut.)
2. A unified screw should have 8 threads per inch if its nominal diameter exceeds 1 inch.

* Nominal size "600 mm" requires hexagon bolt for setting.

Example

Long bolts: 12 - M22 × 185 × 45
 Quantity Nominal size (M) Length of bolt (L) Effective screw length (S)

Setting bolts: 4 - M30 × 95 × 65
 (Hexagon bolts) Quantity Nominal size (M) Length of bolt (L) Effective screw length (S)

Long bolts and nuts

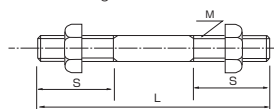

Setting bolts (Hexagon bolts)

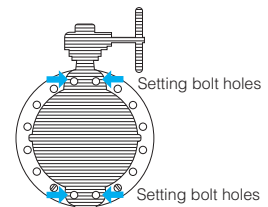
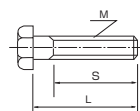

Butterfly Valve
TRITEC
TT2
334A
344Q
302A/303Q
304A/304Q
304YA
302Y/304Y
304M (HLV)
507V/508V
DTM
846T/847T/847Q
841T/842T
700Z
700G/704G/705G
72WG/72SG/72LG
731P/732P/732Q/752W
731R
700E/700K/700S
704G/722F/720F
227P
907T/908H (MKT)
903L/901C/905C (Bata-check)

704G Piping Bolts and Nuts Sizes

* Dimensions on the table show when the piping flange hole are tapped. For drilled holes, please consult us.

Nominal size		JIS 5K	JIS 10K	ASME Class 150	DIN NP10 BS 4504 PN10
mm	inch				
50	2	8-M12×30×28	8-M16×35×33	8-5/8-11UNC×38	8-M16×35×33
65	2 1/2	8-M12×35×33	8-M16×35×33	8-5/8-11UNC×40	8-M16×35×33
80	3	8-M16×35×33	16-M16×35×33	8-5/8-11UNC×45	16-M16×40×38
100	4	16-M16×40×38	16-M16×40×38	16-5/8-11UNC×45	16-M16×40×38
125	5	16-M16×40×38	16-M20×45×41	16-3/4-10UNC×50	16-M16×40×38
150	6	16-M16×40×38	16-M20×45×41	16-3/4-10UNC×50	16-M20×45×41
200	8	16-M20×45×41	24-M20×50×46	16-3/4-10UNC×55	16-M20×50×46
250	10	24-M20×50×46	24-M22×50×46	24-7/8- 9UNC×60	24-M20×55×50
300	12	24-M20×55×51	32-M22×55×51	24-7/8- 9UNC×60	24-M20×55×50
350	14	24-M22×60×50	32-M22×60×50	24-1- 8UNC×70	32-M20×60×46
400	16	32-M22×60×50	32-M24×70×50	32-1- 8UNC×70	32-M24×70×50
450	18	32-M22×60×50	40-M24×70×50	32-1· 1/8-8UN ×80	40-M24×70×50
500	20	40-M22×60×50	40-M24×70×50	40-1· 1/8-8UN ×80	40-M24×70×50
600	24	40-M24×70×50	48-M30×75×60	40-1· 1/4-8UN ×90	40-M27×80×60

Remarks:

1. The bolt lengths are in accordance with thickness of steel flanges.
2. A unified screw should have 8 threads per inch if its nominal diameter exceeds 1 inch.
3. The list is exclusively for standard material "SS400".

Example

Long bolts: 12 - M22 × 185 × 45
 Quantity Nominal size (M) Length of bolt (L) Effective screw length (S)

Setting bolts: 4 - M30 × 95 × 65
 (Hexagon bolts) Quantity Nominal size (M) Length of bolt (L) Effective screw length (S)

Long bolts and nuts

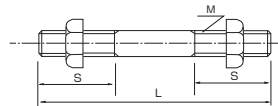

Setting bolts (Hexagon bolts)

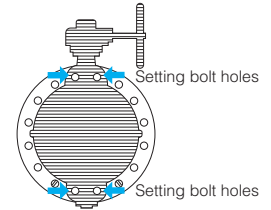
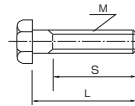

705G Piping Bolts and Nuts Sizes

■ For Hexagon Bolts and Nuts (Flange Bolt Hole: Drilled Holes)

Nominal size		JIS 5K	JIS 10K
mm	inch	Hexagon Bolts and Nuts	Hexagon Bolts and Nuts
40	1 1/2	4-M12× 75×30	4-M16× 90×38
50	2	4-M12× 90×30	4-M16×105×40
65	2 1/2	4-M12× 90×30	4-M16×105×40
80	3	4-M16×105×40	8-M16×110×40
100	4	8-M16×110×40	8-M16×110×40
125	5	8-M16×110×40	8-M20×120×50
150	6	8-M16×120×40	8-M20×130×50
200	8	8-M20×130×50	12-M20×135×50
250	10	12-M20×135×50	12-M22×150×60
300	12	12-M20×150×50	16-M22×160×60
350	14	12-M22×160×60	16-M22×160×60
400	16	16-M22×175×45	16-M24×190×45
450	18	16-M22×185×45	20-M24×205×45
500	20	20-M22×205×45	20-M24×215×45

■ For Long Bolts and Nuts (Flange Bolt Hole: Drilled Holes)

Nominal size		JIS5K	JIS10K	ASME class 125/150
mm	inch	Long Bolts and Nuts	Long Bolts and Nuts	Long Bolts and Nuts
40	1 1/2	4-M12× 95×25	4-M16×110×25	4-U1/2×110×32
50	2	4-M12×105×25	4-M16×120×30	4-U5/8-11UNC×145×45
65	2 1/2	4-M12×110×25	4-M16×125×30	4-U5/8-11UNC×155×50
80	3	4-M16×120×30	8-M16×125×30	4-U5/8-11UNC×155×50
100	4	8-M16×130×30	8-M16×130×30	8-U5/8-11UNC×165×50
125	5	8-M16×130×30	8-M20×150×40	8-U3/4-10UNC×175×55
150	6	8-M16×140×35	8-M20×155×40	8-U3/4-10UNC×175×55
200	8	8-M20×155×40	12-M20×155×40	8-U3/4-10UNC×175×55
250	10	12-M20×165×40	12-M22×175×45	12-U7/8- 9UNC×215×55
300	12	12-M20×175×40	16-M22×185×45	12-U7/8- 9UNC×215×55
350	14	12-M22×185×45	16-M22×185×45	12-U1 - 8UNC×225
400	16	16-M22×205×45	16-M24×220×50	16-U1 - 8UNC×255
450	18	16-M22×225×45	20-M24×230×50	16-U1 1/8- 8UN×280
500	20	20-M22×230×45	20-M24×245×50	20-U1 1/8- 8UN×295

Butterfly Valve
TRITEC
TT2
334A
344Q
302A/303Q
304A/304Q
304YA
302Y/304Y
304M (HLV)
507V/508V
DTM
846T/847T/847Q
841T/842T
700Z
700G/704G/705G
72WG/72SG/72LG
731P/732P/732Q/752W
731R
700E/700K/700S
704G/722F/720F
227P
907T/908H (MKT)
903L/901C/905C (Bata-check)

705G Piping Bolts and Nuts Sizes

For Hexagon Bolts and Nuts (Flange Bolt Hole: Tapped Holes)

Nominal size		JIS 5K		JIS 10K	
mm	inch	Hexagon Bolts and Nuts	Setting Bolts	Hexagon Bolts and Nuts	Setting Bolts
40	1 1/2	—	8-M12× 25×23	—	8-M16× 30×28
50	2	—	8-M12× 30×28	—	8-M16× 35×32
65	2 1/2	—	8-M12× 35×33	—	8-M16× 35×32
80	3	—	8-M16× 35×33	4-M16×110×40	8-M16× 35×32
100	4	4-M16×110×40	8-M16× 40×38	4-M16×110×40	8-M16× 40×38
125	5	4-M16×110×40	8-M16× 40×38	4-M20×120×50	8-M20× 45×41
150	6	4-M16×120×40	8-M16× 40×38	4-M20×130×50	8-M20× 45×41
200	8	4-M20×130×50	8-M20× 45×41	8-M20×135×50	8-M20× 50×46
250	10	8-M20×135×50	8-M20× 50×46	8-M22×150×60	8-M22× 55×50
300	12	8-M20×150×50	8-M20× 55×51	12-M22×160×60	8-M22× 60×55
350	14	8-M22×160×60	8-M22× 60×50	12-M22×160×40	8-M22× 60×50
400	16	12-M22×175×45	8-M22× 60×50	12-M24×190×45	8-M24× 70×50
450	18	12-M22×185×45	8-M22× 60×50	16-M24×205×45	8-M24× 70×50
500	20	16-M22×205×45	8-M22× 60×50	16-M24×215×45	8-M24× 70×50
550	22	16-M24×235×50	8-M24× 65×54	16-M30×255×60	8-M30× 80×66
600	24	16-M24×230×50	8-M24× 70×54	20-M30×255×50	8-M30× 70×60

For Long Bolts and Nuts (Flange Bolt Hole: Tapped Holes)

Nominal size		JIS5K		JIS10K		ASME class 125/150	
mm	inch	Long Bolts and Nuts	Setting Bolts	Long Bolts and Nuts	Setting Bolts	Long Bolts and Nuts	Setting Bolts
40	1 1/2	—	8-M12× 25×23	—	8-M16× 30×28	—	8-U1/2×30×25
50	2	—	8-M12× 30×28	—	8-M16× 35×33	—	8-U5/8-11UNC×35×30
65	2 1/2	—	8-M12× 35×33	—	8-M16× 35×33	—	8-U5/8-11UNC×40×30 (8-U5/8-11UNC×35×30)
80	3	—	8-M16× 35×33	4-M16×125×30	8-M16× 35×33	—	8-U5/8-11UNC×45×38 (8-U5/8-11UNC×40×30)
100	4	4-M16×130×30	8-M16× 40×38	4-M16×130×30	8-M16× 40×38	4-U5/8-11UNC×165×50	8-U5/8-11UNC×45×38
125	5	4-M16×130×30	8-M16× 40×38	4-M20×150×40	8-M20× 45×41	4-U3/4-10UNC×175×55	8-U3/4-10UNC×50×44
150	6	4-M16×140×35	8-M16× 40×38	4-M20×155×40	8-M20× 45×41	4-U3/4-10UNC×175×55	8-U3/4-10UNC×50×44
200	8	4-M20×155×40	8-M20× 45×41	8-M20×155×40	8-M20× 50×46	4-U3/4-10UNC×175×55	8-U3/4-10UNC×55×44
250	10	8-M20×165×40	8-M20× 50×46	8-M22×175×45	8-M22× 55×50	8-U7/8- 9UNC×215×55	8-U7/8- 9UNC×60×50
300	12	8-M20×175×40	8-M20× 55×51	12-M22×185×45	8-M22× 60×55	8-U7/8- 9UNC×215×55	8-U7/8- 9UNC×60×50
350	14	8-M22×185×45	8-M22× 60×50	12-M22×185×45	8-M22× 60×50	8-U1 - 8UNC×225	8-U1 - 8UNC×70×57
400	16	12-M22×205×45	8-M22× 60×50	12-M24×220×50	8-M24× 70×50	12-U1 - 8UNC×255	8-U1 - 8UNC×75×57
450	18	12-M22×225×45	8-M22× 60×50	16-M24×230×50	8-M24× 70×50	12-U1 1/8- 8UNC×280	8-U1 1/8-8UNC×85×63
500	20	16-M22×230×45	8-M22× 60×50	16-M24×245×50	8-M24× 70×50	16-U1 1/8- 8UNC×295	8-U1 1/8-8UNC×85×63
550	22	16-M24×265×50	8-M24× 65×54	16-M30×290×60	8-M30× 80×66	—	—
600	24	16-M24×275×50	8-M24× 70×54	20-M30×290×60	8-M30× 75×60	16-U1 1/4- 8UNC×340	8-U1 1/4-8UNC×95×70

Remarks:
 Bolt/Nut material: SS400/SS400, SUS304/SUS304
 The dimensions in parenthesis show ASME class 125. (for 65 mm and 80 mm)
 Heavy nut shall be used for ASME class 125/150 hexagon nuts.
 A unified screw should have 8 threads per inch if its nominal diameter exceeds 1 inch.

Example

Long bolts: 12 - M22 × 185 × 45
 Quantity Nominal size (M) Length of bolt (L) Effective screw length (S)

Setting bolts: 4 - M30 × 95 × 65
 (Hexagon bolts) Quantity Nominal size (M) Length of bolt (L) Effective screw length (S)

