

High Performance Butterfly Valves to suit API standard class 150/300 Rating

334A

Valve nominal size

50 to 600mm

Max. working pressure MPa

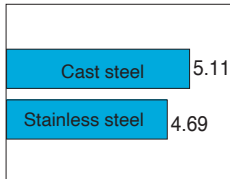

Working temperature range °C

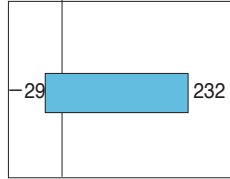

FS Fire safe certification to API607 4th Ed.

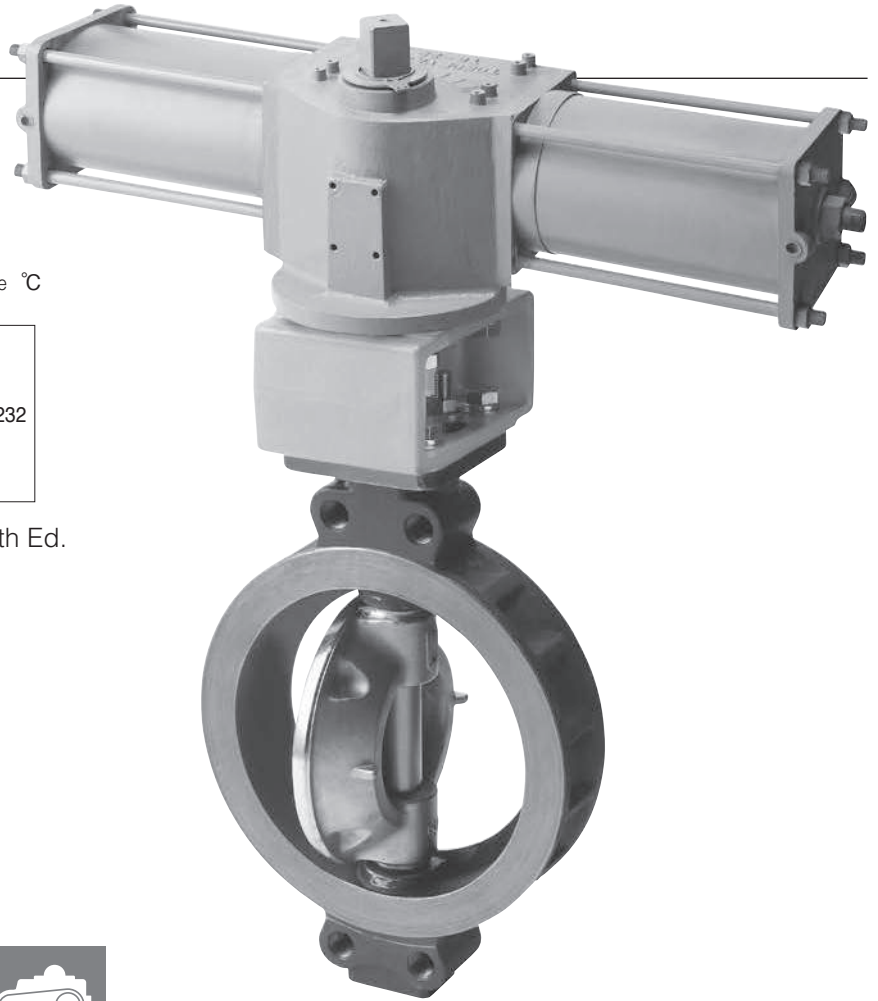

Features and Benefits

Double Offset PTFE Seated
High Performance Butterfly Valve to Suit API
Standard Fire Safe Certification As Optional

General description

Designed to suit those severe conditions such as high temperature, high pressure or high velocity which disallow the use of soft resilient seated butterfly valves. Ideal for use including chemical processes, and applications with low pressure steam and high temperature gas. The valve is available for class 150/300 .

Double offset geometry

The design exhibits tight shut off, reduced torques, chemical resistance, excellent throttling capabilities, and the ability to operate with relatively high pressure drops.

Characteristics

Fire safe certification to API607 4th Ed.

50mm : API607-5th edition Fire safe

80~600mm : API607-4th edition Fire safe ※

※ class 300-150mm/water body which standard is JIS16K/20K not be Applicable Fire safe. (it can not have necessary thickness.)

RPTFE as standard

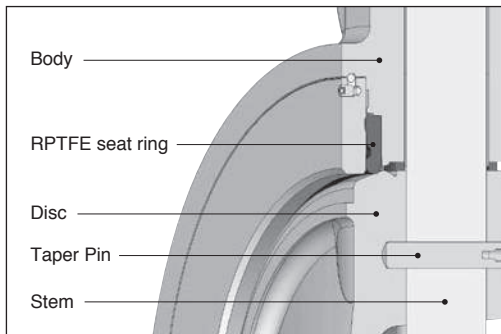

334A Fire Safe Seat (API607 4th Ed.)

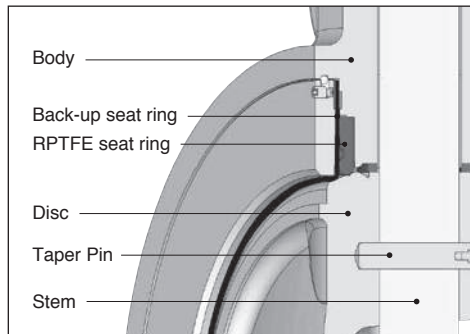

Standard Specifications

Product characteristics	Double offset soft seated butterfly valve		
Conection	Wafer type / Lugged type		
Nominal valve size ※1	50, 80, 100, 150, 200, 250, 300, 350, 400, 450, 500, 600mm		
Applicable standards	Face-to-face dimensions	80~600mm: API609 Class150/300 Category B 50mm: API609 Category A, ISO5752 Wafer butterfly valve	
	Flange accommodation (Wafer)※2	class 150: ASME/JPI Class150, JIS 10K/16K/20K, BS 4504 PN10/16, DIN PN10/16 class 300: ASME/JPI Class300, JIS 20K/30K, BS 4504 PN25/40, DIN PN25/40	
	Actuator attachment	ISO5211/1 (other than class 300-600mm)	
	P-T rating	ASME B16.34 / API609	
Applicable fluid	General hydrocarbon, Chemical process, steam, gas etc.		
Max.working pressure	class 150: 2.0MPa (Body material : Both WCB and CF8M) class 300: 5.1MPa (Body material : WCB), 4.96MPa (Body material : CF8M)		
Working temperature range	-29 degree C to 232 degree C		
Pressure direction	Standard pressure direction : Pressure on retainer side		
Test Pressure	Shell test	Working pressure x 1.5 times (Hydrostatic pressure)	
	Seat leakage	0.7MPa(Air pressure) Based on API598-8thEdition Option : Working pressure x 1.1 times (Hydrostatic pressure)	
Standard Materials ※3	Body	ASTM A216 WCB	ASTM A351 CF8M
	Disc	ASTM A351 CF8M with hard chrome plating	
	Shaft	SUS420J2 ※4	630SS H1150 ※4
	Seat ring	RPTFE(Carbon graphite contained)	
	Retainer	S35C ※4	316SS ※4
	Gland Packing	Graphite	
Shaft shape for actuator conection	class 150: 50mm to 250mm : Square / 300mm to 600mm : Key class 300: 50mm to 150mm : Square / 200mm to 600mm : Key		
Actuator	Lock lever, Worm gear, Pneumatic cylinder, Electric motor		
Coating	Silicon resin coating (Grey N7) for 200 degrees C or lower. Heat resistant silver coating for over 200 degrees C. No coating for stainless steel.		
Usable Gasket	Sheet gasket : Marketed products available Spiral wound gasket : Marketed products (with inner & outer ring) available only for ASME/JPI Class 150 and 300 For other flange standards, special gasket for TOMOE is required.		
Option	50mm : API607-5th edition Fire safe 80~600mm : API607-4th edition Fire safe ※5		

※1 Please contact us for the requirement of 125mm.

※2 Please contact us for the detail of flange accommodation including lugged type.

※3 Special specification with aluminium bronze is also available. When materials other than standard are selected, the working pressure might be limited. Please consult us for the details.

※4 In case of Body material is WCB : Shaft /SUS420J2, Retainer/S35C In case of Body materials is CF8M : Shaft/630SS+H1150, Retainer/316SS

※5 300Lb-150mm/wafer body with flange standard JIS16K/20K is not applicable to fire-safe duties.

※There is possibility of seat leakage when fluid (powder/liquid) is solidified by working temperature and other cause, especially the valve is in a vertical position(e.g. at the bottom area of discharge spout of hopper and tank). Please consult us.

Model type

Type	Wafer type		Lugged type	
	class 150	class 300	class 150	class 300
Standard	324A	334A	324Q	334Q
Fire safe	344A	354A	344Q	354Q

Butterfly Valve
TRITEC
TT2
334A
344Q
302A/303Q
304A/304Q
304YA
302Y/304Y
304M (HLV)
507V/508V
DTM
846T/847T/847Q
841T/842T
700Z
700G/704G/705G
72WG/72SG/72LG
731P/732P/732Q/752W
731R
700E/700K/700S
704G/722F/720F
227P
907T/908H (MKT)
903L/901C/905C (Bata-check)

334A Expanded view of bare shaft

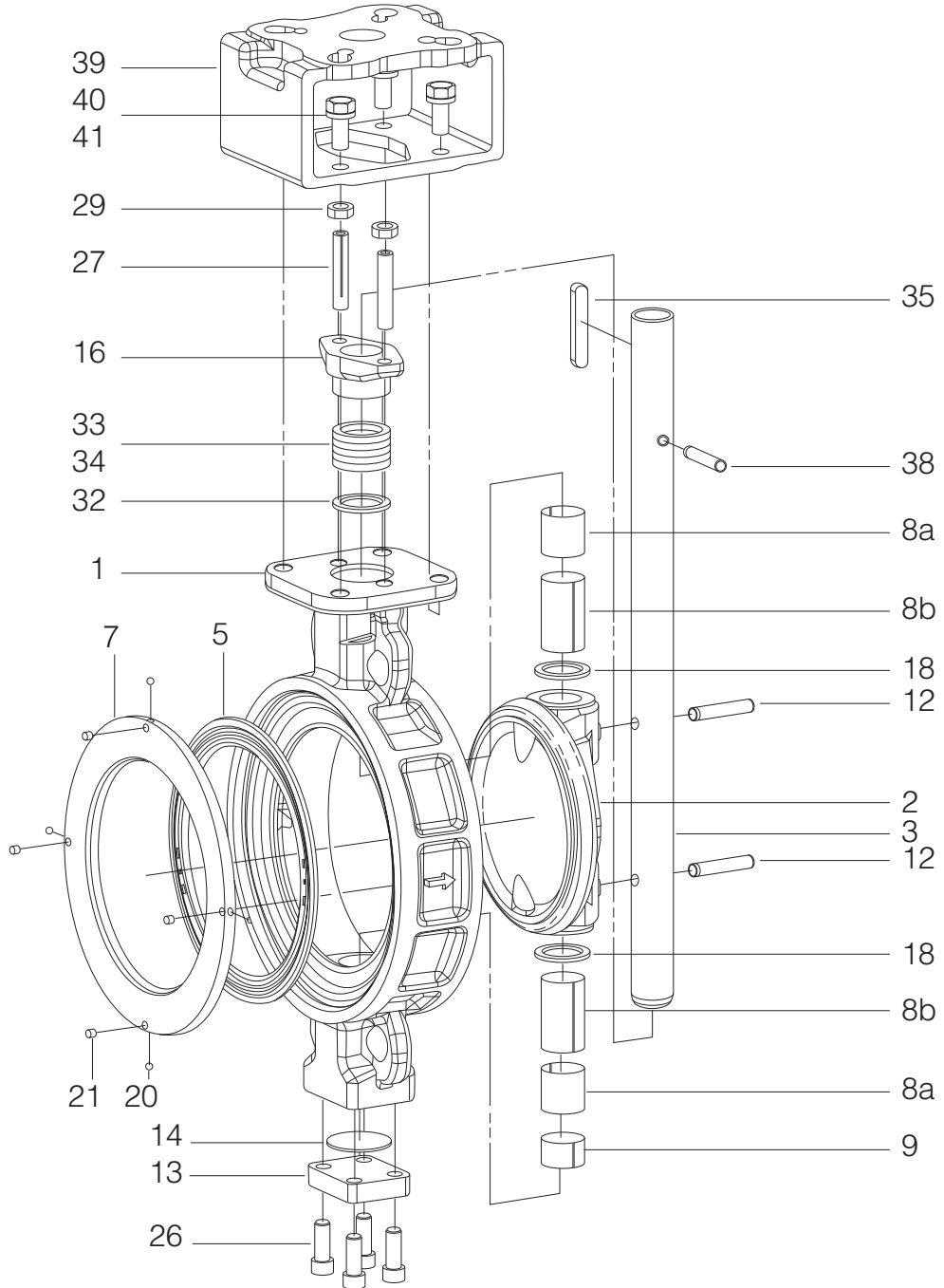

334A Bare shaft parts list

■334A Bare shaft parts list-class 150

No.	Description	Q'ty	Remarks
1	Body	1	
2	Disc	1	
3	Stem	1	
5	Seat ring	1	
7	Seat ring retainer	1	
8a	Bearing a	0	600mm
		1	300mm
		2	80mm to 150mm, 500mm
		3	50mm, 200mm
		4	250mm, 350mm
		6	400mm, 450mm
8b	Bearing b	0	400mm, 450mm
		1	80mm, 100mm, 200mm, 250mm, 350mm
		2	50mm, 150mm, 500mm
		3	300mm
		4	600mm
9	Bearing spacer	1	
12	Taper pin	2	50mm to 300mm
		3	350mm to 600mm
13	Bottom cover	1	
14	Bottom gasket	1	
16	Gland plate spigot	1	
18	Space ring	2	
20	Ball	2	50mm, 100mm
		4	150mm to 600mm
21	Set screw	2	50mm, 100mm
		4	150mm to 600mm
26	Hexagon hole bolt	4	
27	Gland bolt	2	
29	Hexagon nut	2	
32	Packing retainer	1	
33	Gland packing a	3	
34	Gland packing b	2	
35	Key	0	50mm to 150mm
		1	200mm to 600mm
38	Spring pin	1	
39	Column	1	
40	Hexagon bolt	4	
41	Spring washer	4	

■334A Bare shaft parts list-class 300

No.	Description	Q'ty	Remarks
1	Body	1	
2	Disc	1	
3	Stem	1	
5	Seat ring	1	
7	Seat ring retainer	1	
8a	Bearing a	2	50mm:3
8b	Bearing b	1	80mm to 150mm
		2	50mm, 200mm to 600mm
9	Bearing spacer	1	
12	Taper pin	2	50mm to 200mm
		3	250mm to 600mm
13	Bottom cover	1	
14	Bottom gasket	1	
16	Gland plate spigot	1	
18	Space ring	2	
20	Ball	2	50mm to 100mm
		4	150mm to 600mm
21	Set screw	2	50mm to 100mm
		4	150mm to 600mm
26	Hexagon hole bolt	4	
27	Gland bolt	2	
29	Hexagon nut	2	
32	Packing retainer	1	
33	Gland packing a	3	
34	Gland packing b	2	
35	Key	0	50mm to 150mm
		1	200mm to 600mm
38	Spring pin	1	
39	Column	1	
40	Hexagon bolt	4	
41	Spring washer	4	

Butterfly Valve

TRITEC

TT2

334A

344Q

302A/303Q

304A/304Q

304YA

302Y/304Y

304M

(HLV)

507V/508V

DTM

846T/847T/847Q

841T/842T

700Z

700G/704G/705G

72WG/72SG/72LG

731P/732P/

732Q/752W

731R

700E/700K/700S

704G/722F/720F

227P

907T/908H

(MKT)

903L/901C/

905C(Bata-check)

334A

334A Actuator Selection Chart

334A-class 150

Type	Model	Category	Size ($\frac{mm}{inch}$)											
			50	80	100	150	200	250	300	350	400	450	500	600
			2	3	4	6	8	10	12	14	16	18	20	24
Lock lever	1T	T10	1T-1	1T-2										
		T20												
Worm gear	2U,2K	T10	2U-1	2U-2	2U-3	2U-4	2K (SBWG-01)	2K (SBWG-02)	2K (SBWG-03)	2K (SBWG-04-1S)				
		T20												
Double-action pneumatic	7E,3A	T10	T85	T200	T380	T750	TGA-125	TGA-140	TGA-160	TGA-180				
		T20									TGA-140	TGA-160	TGA-180	TGA-200
Single-action pneumatic	7G,7F 3U,3K	T10	T200S	T380S	T750S	TG-12S	TG-14S	TG-20S						
		T20												
Single phase motor	4I	T10	4I-0	4I-1	4I-2	4I-2.5	4I-3	4I-4						
		T20												

334A Pressure - Temperature

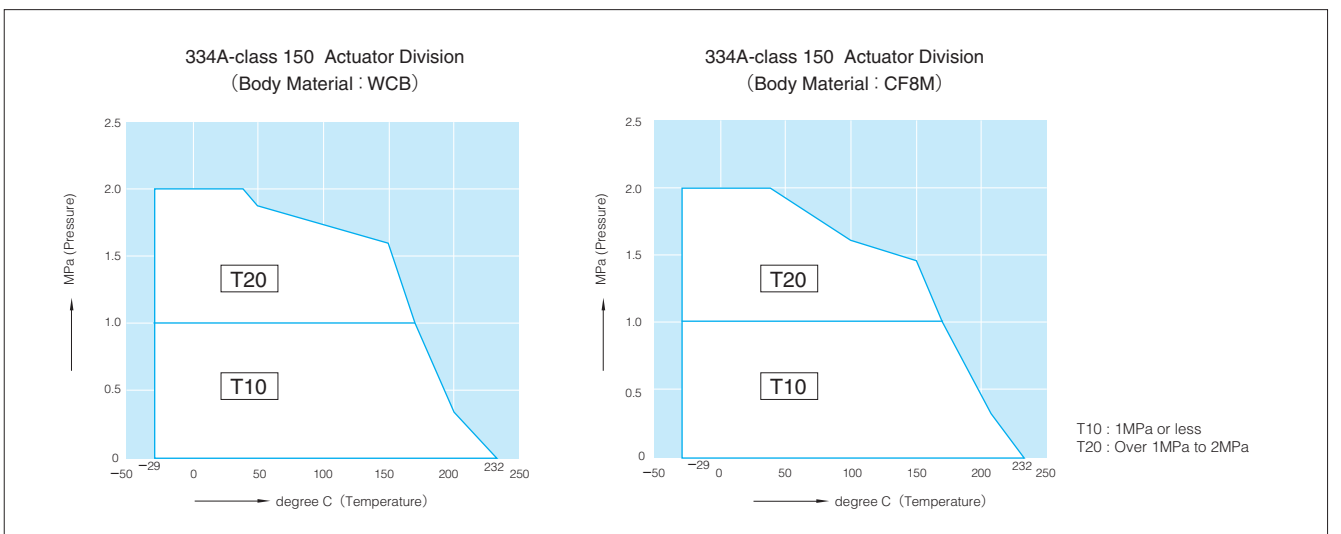

334A Actuator Selection Chart

334A-class 300

Type	Model	Category	Size $\left(\frac{\text{mm}}{\text{inch}}\right)$												
			50	80	100	150	200	250	300	350	400	450	500	600	
			2	3	4	6	8	10	12	14	16	18	20	24	
Lock lever	1T	A	1T-1	1T-2											
		B													
		C													
		D													
Worm gear	2U,2K	A	2U-1	2U-2			2U-3	2U-4	2K (SBWG01)	2K (SBWG02)	2K (SBWG03)	2K (SBWG03-1S)	2K (SBWG04-1S)		2K (SBWG05-1S)
		B													
		C													
		D													
Double-action pneumatic	7E,3A	A	T85	T200		T380	T750	TGA-125	TGA-125		TGA-140		TGA-160	TGA-180	TGA-200
		B													
		C													
		D													
Single-action pneumatic	7G,7F 3U,3K	A	T200S	T380S	T750S	TG-12S	TG-14S		TG-20S						
		B													
		C													
		D													
Single phase motor	4I	A	4I-0	4I-1	4I-2	4I-2.5		4I-3	4I-4						
		B													
		C													
		D													

Butterfly Valve
TRITEC
TT2
334A
344Q
302A/303Q
304A/304Q
304YA
302Y/304Y
304M (HLV)
507V/508V
DTM
846T/847T/847Q
841T/842T
700Z
700G/704G/705G
72WG/72SG/72LG
731P/732P/732Q/752W
731R
700E/700K/700S
704G/722F/720F
227P
907T/908H (MKT)
903L/901C/905C (Bata-check)

334A Pressure Rating

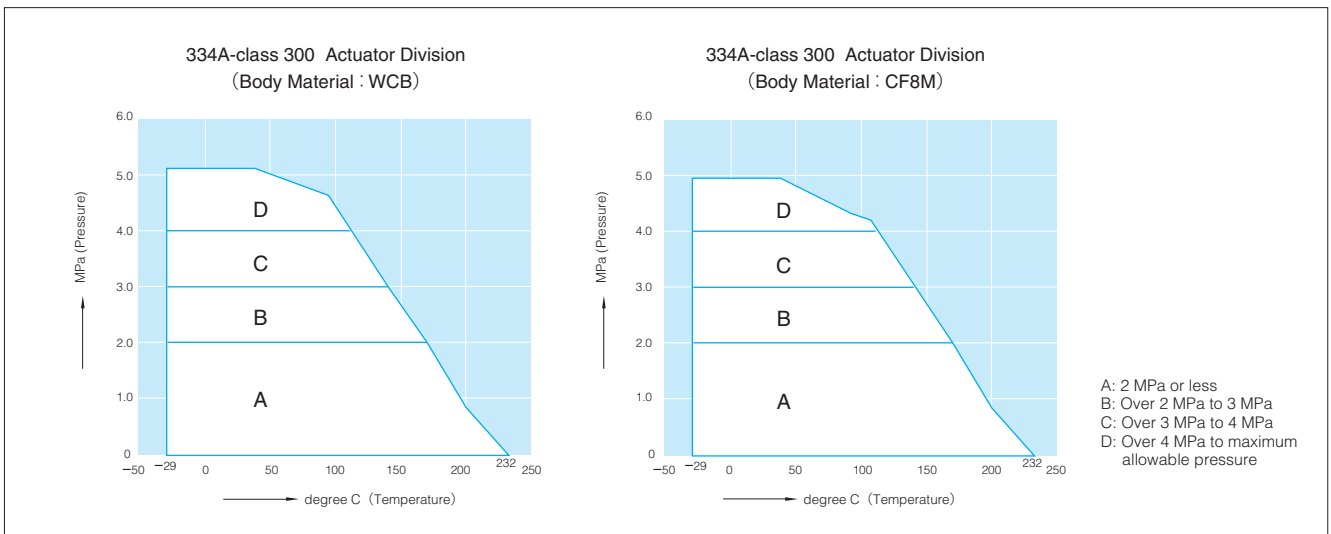

334A

334A Bare Shaft Dimension

class 150

Nominal size		Dimension (mm)														Approx. Weight (kg)	
mm	inch	ϕd	ϕD	L	L ₂	H ₁	H ₂	a ₁	a ₂	□S1	ϕd_2	b	t ₂	H ₄	t		Top Flange type
50	2	60	97	43	17.5	102.5	102.5	22.5	11.5	12	14	—	—	70	8	F07, F10	5.7
80	3	86.5	128	48	20	118	127	26.5	16.5	14	18	—	—	70	8	F07, F10	8
100	4	112	158	54	22	147	149	26.5	20	16	20	—	—	70	8	F07, F10	10.7
150	6	160	216	57	23	186	190	26.5	20	18	22	—	—	98	12	F10, F12, F14	18.9
200	8	210	270	64	26.5	201	209.2	37	30	22	26	—	—	98	12	F10, F12, F14	25.6
250	10	260	324	71	29	254	253	37	34	24	30	—	—	98	12	F10, F12, F14	39
300	12	310	382	81	36	283	280.5	72	67	—	32	10	3	98	12	F10, F12, F14	49
350	14	347	415	92	37	313	301	72	67	—	37	10	3	125	16	F14, F16	73
400	16	402	473	102	40	348	350	86	81	—	42	12	3	125	16	F14, F16	101
450	18	446	534	114	46	394	383.6	86	81	—	45	14	3.5	125	16	F14, F16	145
500	20	497	586	127	55	421	409.2	86	81	—	52	16	4	125	16	F14, F16	179
600	24	600	694	154	70	481	473	116	111	—	60	18	4	150	20	F25, Special A	304

class 150 80mm to 600mm

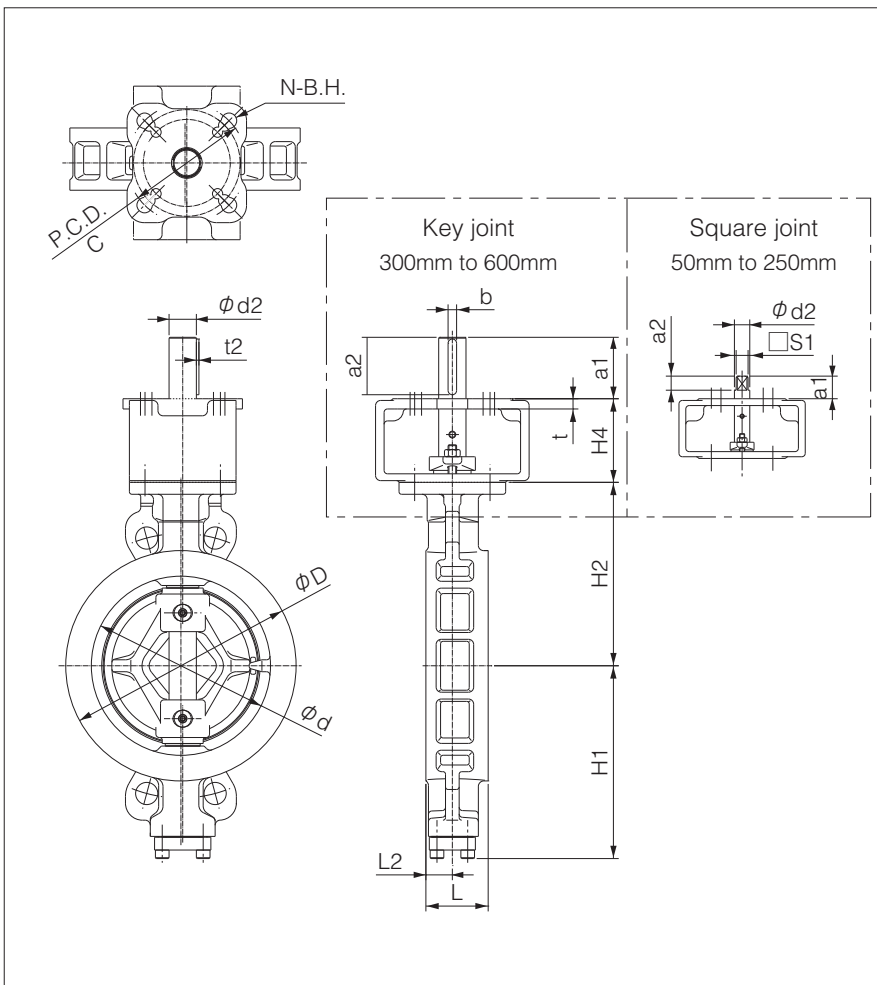

Top Flange Type Dimension List

Flange type	P.C.D. C	N	B.H.
F07	70	4	10
F10	102	4	12
F12	125	4	14
F14	140	4	18
F16	165	4	22
F25	254	8	18
Special A	220	4	22

334A Bare Shaft Dimension

class 300

Nominal size		Dimension (mm)														Approx. Weight (kg)	
mm	inch	ϕd	ϕD	L	L ₂	H ₁	H ₂	a ₁	a ₂	$\square S_1$	ϕd_2	b	t ₂	H ₄	t		Top Flange type
50	2	60	97	43	17.5	102.5	102.5	22.5	11.5	12	14	—	—	70	8	F07, F10	5.7
80	3	86.5	128	48	20	118	127	26.5	16.5	14	18	—	—	70	8	F07, F10	8
100	4	112	158	54	22	147	149	26.5	20	16	20	—	—	70	8	F07, F10	10.7
150	6	160	216	59	24	192	187	37	30	22	26	—	—	98	12	F10, F12, F14	21.4
200	8	210	270	73	31	226	215	72	67	—	32	10	3	98	12	F10, F12, F14	32
250	10	260	326	83	36	260	253	72	67	—	37	10	3	125	16	F14, F16	60
300	12	310	385	92	42	292	294.5	86	81	—	42	12	3	125	16	F14, F16	83
350	14	347	420	117	52	338	326	86	81	—	45	14	3.5	125	16	F14, F16	113
400	16	402	476	133	61.5	376	364	86	81	—	52	16	4	125	16	F14, F16	157
450	18	446	536	149	70	402	394.5	116	111	—	60	18	4	150	20	F25, Special A	231
500	20	497	590	159	75	431	426.5	116	111	—	65	18	4	150	20	F25, Special A	283
600	24	600	701	181	84	504	496	136	131	—	70	20	4.5	150	20	Special A, Special B	433

class 300 80mm to 600mm

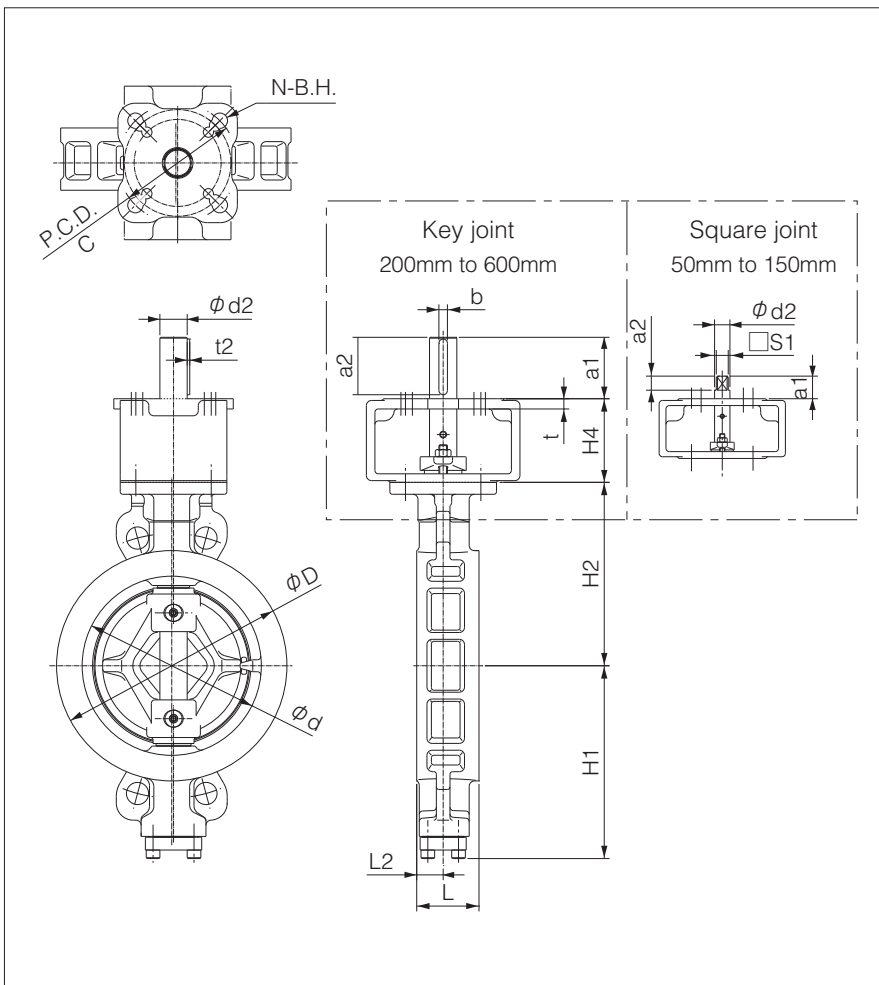

Top Flange Type Dimension List

Flange type	P.C.D. C	N	B.H.
F07	70	4	10
F10	102	4	12
F12	125	4	14
F14	140	4	18
F16	165	4	22
F25	254	8	18
Special A	220	4	22
Special B	254	8	22

Butterfly Valve
TRITEC
TT2
334A
344Q
302A/303Q
304A/304Q
304YA
302Y/304Y
304M (HLV)
507V/508V
DTM
846T/847T/847Q
841T/842T
700Z
700G/704G/705G
72WG/72SG/72LG
731P/732P/732Q/752W
731R
700E/700K/700S
704G/722F/720F
227P
907T/908H (MKT)
903L/901C/905C (Bata-check)

334A

Worm Gear Type-150Lb 334A-2U(50 to 300mm) / 334A-2K(350 to 600mm)

class 150

Nominal size		Dimension (mm)												Gear type	Approx. Weight (kg)
mm	inch	ϕd	ϕD	L	L_2	H_1	H_2	H_3	H_4	E	K	F	ϕW		
50	2	60	97	43	17.5	102.5	102.5	29.5	70	36	74	160	100	2U-1	8
80	3	86.5	128	48	20	118	127	34.5	70	44	74	173.5	160	2U-2	12.5
100	4	112	158	54	22	147	149	34.5	70	44	74	173.5	160	2U-2	15
150	6	160	216	57	23	186	190	41.5	98	67	90	198	200	2U-3	27
200	8	210	270	64	26.5	201	209.2	41.5	98	67	90	198	200	2U-3	34
250	10	260	324	71	29	254	253	48	98	87.5	90	222.5	280	2U-4	55
300	12	310	382	81	36	283	280.5	48	98	87.5	90	222.5	280	2U-4	65
350	14	347	415	92	37	313	301	52	125	75	113	252	370	SBWG-01	79
400	16	402	473	102	40	348	350	63	125	91.5	113	310	450	SBWG-02	123
450	18	446	534	114	46	394	384	63	125	113	113	343	550	SBWG-03	173
500	20	497	586	127	55	421	409	63	125	113	113	343	550	SBWG-03	207
600	24	600	694	154	70	481	473	85	150	32.7	200	422	710	SBWG-04-1S	363

334A-2U/2K

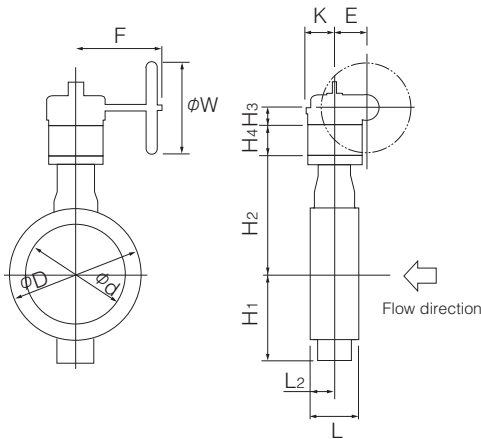

2U/2K Installation Direction

2UA / 2KA	2UB / 2KB	2UC / 2KC	2UD / 2KD

Worm Gear Type-300Lb 334A-2U (50 to 200mm) / 334A-2K(250 to 600mm)

■class 300

Nominal size		Dimension (mm)												Gear type	Approx. Weight (kg)
mm	inch	ϕd	ϕD	L	L ₂	H ₁	H ₂	H ₃	H ₄	E	K	F	ϕW		
50	2	60	97	43	17.5	102.5	102.5	29.5	70	36	74	160	100	2U-1	8.0
80	3	86.5	128	48	20	118	127	34.5	70	44	74	173.5	160	2U-2	12.5
100	4	112	158	54	22	147	149	34.5	70	44	74	173.5	160	2U-2	15
150	6	160	216	59	24	192	187	41.5	98	67	90	198	200	2U-3	29
200	8	210	270	73	31	226	215	48	98	87.5	90	222.5	280	2U-4	48
250	10	260	326	83	36	260	253	52	125	75	113	360	400	SBWG-01	72
300	12	310	385	92	42	292	294.5	63	125	91.5	113	418.5	500	SBWG-02	104
350	14	347	420	117	52	338	326	63	125	113	113	452	560	SBWG-03	141
400	16	402	476	133	61.5	376	364	63	125	31.5	113	481	560	SBWG-03-1S	190
450	18	446	536	149	70	402	394.5	85	150	32.7	200	550	630	SBWG-04-1S	306
500	20	497	590	159	75	431	426.5	85	150	32.7	200	550	630	SBWG-04-1S	358
600	24	600	701	181	84	504	496	87	150	72.7	200	599.5	710	SBWG-05-1S	531

■334A-2U/2K

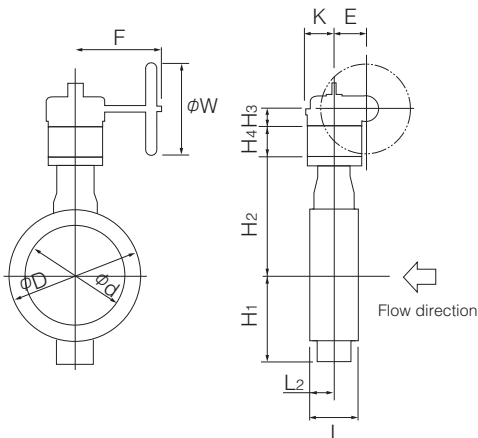

Butterfly Valve
TRITEC
TT2
334A
344Q
302A/303Q
304A/304Q
304YA
302Y/304Y
304M (HLV)
507V/508V
DTM
846T/847T/847Q
841T/842T
700Z
700G/704G/705G
72WG/72SG/72LG
731P/732P/732Q/752W
731R
700E/700K/700S
704G/722F/720F
227P
907T/908H (MKT)
903L/901C/905C (Bata-check)

■2U/2K Installation Direction

2UA/2KA	2UB/2KB	2UC/2KC	2UD/2KD

334A-class 150 Cv value and pressure loss coefficient

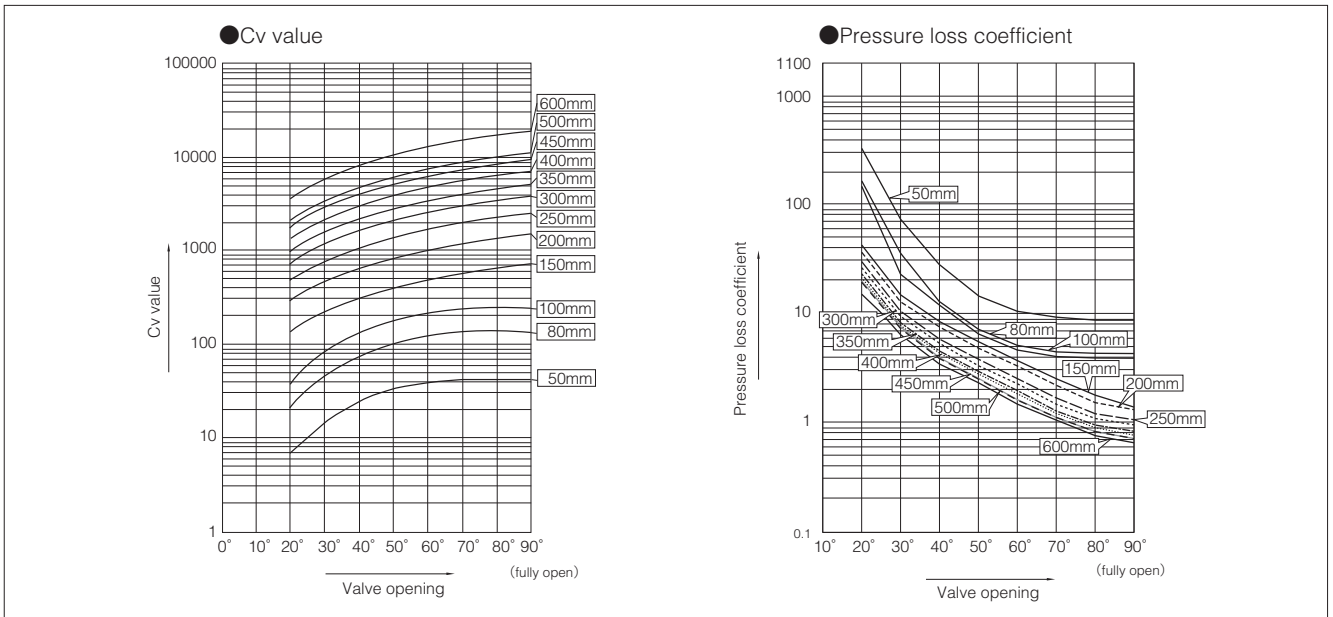

334A -class 150 Cv value

Nominal size		Valve opening							
mm	inch	20°	30°	40°	50°	60°	70°	80°	90°
50	2	7	15	24	33	39	42	43	43
80	3	22	47	77	104	124	134	135	136
100	4	38	83	135	184	219	236	238	240
150	6	140	231	310	385	471	573	677	729
200	8	295	488	655	814	995	1211	1430	1540
250	10	479	792	1063	1321	1615	1966	2321	2500
300	12	747	1236	1659	2061	2519	3066	3621	3900
350	14	1002	1657	2225	2765	3378	4112	4856	5230
400	16	1379	2281	3063	3806	4651	5661	6685	7200
450	18	1835	3035	4075	5064	6188	7533	8895	9580
500	20	2146	3549	4764	5920	7235	8806	10399	11200
600	24	3583	5925	7955	9885	12080	14703	17362	18700

334A -class 150 Pressure loss coefficient

Nominal size		Valve opening							
mm	inch	20°	30°	40°	50°	60°	70°	80°	90°
50	2	33.6	73.3	28.6	15.1	10.8	9.4	8.9	8.9
80	3	171.9	36.3	13.5	7.3	5.2	4.4	4.4	4.3
100	4	156.9	33.2	12.3	6.7	4.7	4.1	4.0	3.9
150	6	42.5	15.6	8.6	5.6	3.7	2.5	1.8	1.6
200	8	37.5	13.7	7.6	4.9	3.3	2.2	1.6	1.4
250	10	29.3	10.7	5.9	3.8	2.6	1.7	1.3	1.1
300	12	25.8	9.4	5.2	3.4	2.3	1.5	1.1	1.0
350	14	22.2	8.1	4.5	2.9	2.0	1.3	1.0	0.8
400	16	21.2	7.8	4.3	2.8	1.9	1.3	0.9	0.8
450	18	19.3	7.1	3.9	2.5	1.7	1.1	0.8	0.7
500	20	19.2	7.0	3.9	2.5	2.1	1.1	0.8	0.7
600	24	18.0	6.6	3.6	2.4	1.6	1.1	0.8	0.7

334A-class 300 Cv value and pressure loss coefficient

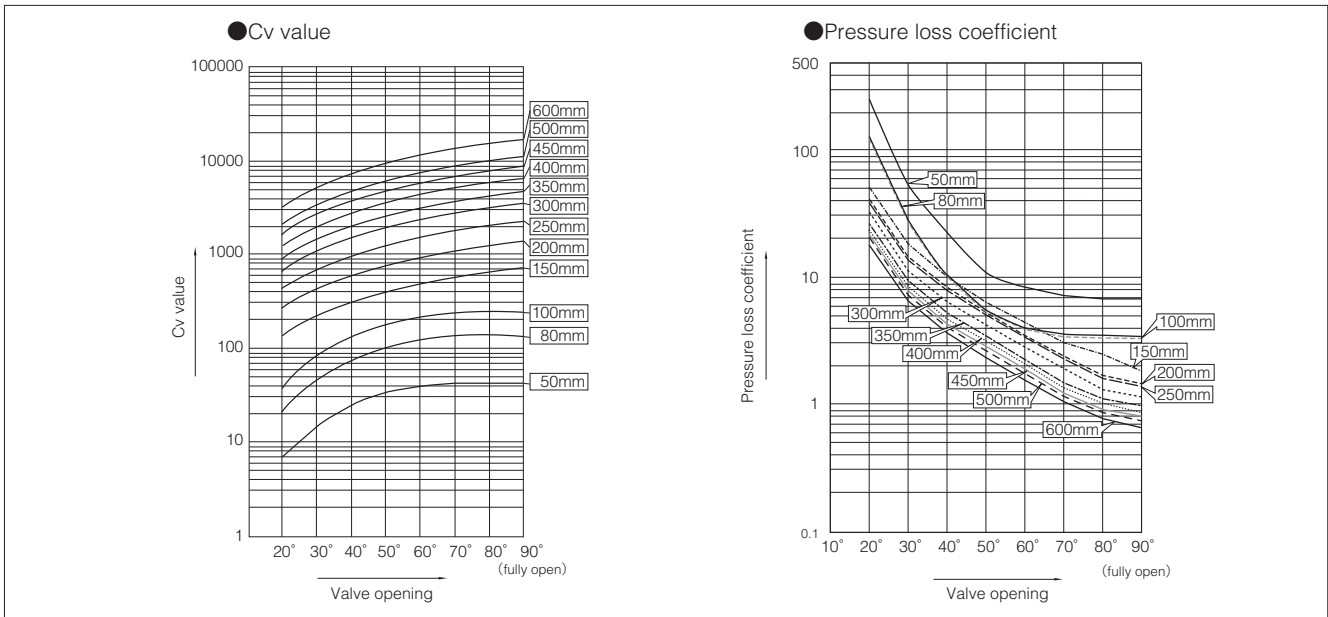

Butterfly Valve

TRITEC

TT2

334A

344Q

302A/303Q

304A/304Q

304YA

302Y/304Y

304M (HLV)

507V/508V

DTM

846T/847T/847Q

841T/842T

700Z

700G/704G/705G

72WG/72SG/72LG

731P/732P/732Q/752W

731R

700E/700K/700S

704G/722F/720F

227P

907T/908H (MKT)

903L/901C/905C (Bata-check)

334A -class 300 Cv value

Nominal size		Valve opening							
mm	inch	20°	30°	40°	50°	60°	70°	80°	90°
50	2	7	15	24	33	39	42	43	43
80	3	22	47	77	104	124	134	135	136
100	4	38	83	135	184	219	236	238	240
150	6	139	230	309	384	470	572	675	727
200	8	270	446	599	744	909	1106	1306	1407
250	10	436	720	967	1202	1469	1787	2111	2273
300	12	677	1120	1503	1868	2283	2778	3281	3533
350	14	909	1503	2018	2508	3065	3730	4405	4744
400	16	1249	2065	2773	3445	4210	5125	6052	6518
450	18	1664	2751	3694	4590	5609	6828	8062	8683
500	20	2122	3510	4712	5855	7155	8710	10285	11077
600	24	3245	5366	7205	8953	10941	13317	15725	16937

334A -class 300 Pressure loss coefficient

Nominal size		Valve opening							
mm	inch	20°	30°	40°	50°	60°	70°	80°	90°
50	2	262.0	57.1	22.3	11.8	8.4	7.3	6.9	6.9
80	3	136.3	28.8	10.7	5.8	4.1	3.5	3.5	3.4
100	4	132.5	28.0	10.4	5.6	4.0	3.4	3.4	3.3
150	6	50.6	18.5	10.3	6.7	4.5	3.0	2.2	1.9
200	8	41.4	15.1	8.4	5.4	3.6	2.5	1.8	1.5
250	10	39.2	14.3	8.0	5.2	3.5	2.3	1.7	1.4
300	12	32.5	11.9	6.6	4.3	2.9	1.9	1.4	1.2
350	14	26.3	9.6	5.3	3.5	2.3	1.6	1.1	1.0
400	16	23.9	8.8	4.9	3.1	2.1	1.4	1.0	0.9
450	18	21.7	7.9	4.4	2.9	1.9	1.3	0.9	0.8
500	20	20.5	7.5	4.2	2.7	1.8	1.2	0.9	0.8
600	24	18.3	6.7	3.7	2.4	1.6	1.1	0.8	0.7

334A Flange accommodation

■class 150 Wafer Type

Nominal size		ASME/JPI class 150	JIS 10K	JIS 16/20K	BS4504(DIN) PN 10	BS4504(DIN) PN 16
mm	inch					
50	2	○ ^{*1}	○ ^{*1}	D ^{*2}	○ ^{*1}	○ ^{*1}
80	3	○ ^{*1}	D ^{*2}	D ^{*2}	D ^{*2}	D ^{*2}
100	4	D ^{*2}	D ^{*2}	D ^{*2}	D ^{*2}	D ^{*2}
150	6	D ^{*2}	D ^{*2}	D ^{*2}	D ^{*2}	D ^{*2}
200	8	D ^{*2}	D ^{*2}	D ^{*2}	D ^{*2}	D ^{*2}
250	10	D ^{*2}	D ^{*2}	D ^{*2}	D ^{*2}	D ^{*2}
300	12	D ^{*2}	D ^{*2}	D ^{*2}	D ^{*2}	D ^{*2}
350	14	D ^{*2}	D ^{*2}	D ^{*2}	D ^{*2}	D ^{*2}
400	16	D ^{*2}	D ^{*2}	D ^{*2}	D ^{*2}	D ^{*2}
450	18	T	T	T	T	T
500	20	T	T	T	T	T
600	24	T	T	T	T	T

*1 : Can be used without flange drilling.

*2 : There are 2 upper drilling holes for 50mm and 80mm to 250mm types, and a total of 4 drilling holes, 2 upper and 2 lower, for 300mm to 400mm types.

D: With flange drilling

T: With flange tapping

○: Can be used without flange drilling.

■class 150 Lugged Type

Nominal size		ASME/JPI class 150	JIS 10K	JIS 16/20K	BS4504(DIN) PN 10	BS4504(DIN) PN 16
mm	inch					
50	2	T	T	T ^{*1}	T	T
80	3	T	T ^{*1}	T ^{*1}	T ^{*1}	T ^{*1}
100	4	T ^{*1}	T ^{*1}	T ^{*1}	T ^{*1}	T ^{*1}
150	6	T	T	T ^{*1}	T	T
200	8	T	×	T ^{*1}	T	T ^{*1}
250	10	T	T	T	T	T
300	12	T	×	T ^{*1}	T	T
350	14	T	×	×	×	×
400	16	T	T	T	T	T
450	18	T	×	×	×	×
500	20	T	T	T	T	T
600	24	T	×	T ^{*1}	T	T

*1 : Use 300Lb body. In this case, class 300 body of 150mm or more in the nominal size must note that the face-to-face dimensions are different.

* : Please consult with us regarding drilling holes for the lugged type.

T: With flange tapping

×: A special wooden form is required.

334A Flange accommodation

■class 300 Wafer type

Nominal size		ASME/JPI class 300	JIS20K	JIS30K	BS4504(DIN) PN25	BS4504(DIN) PN40
mm	inch					
50	2	D*2	D*2	D*2	○*1	○*1
80	3	D*2	D*2	D*2	D*2	D*2
100	4	D*2	D*2	D*2	D*2	D*2
150	6	D*2	D*2	D*2	D*2	D*2
200	8	D*2	D*2	D*2	D*2	D*2
250	10	T	D*2/ T	D*2/ T	D*2/ T	D*2 (T)
300	12	T	T	T	T	T
350	14	T	T	T	T	T
400	16	T	T	T	T	T
450	18	T	T	X	T	T
500	20	T	T		T	T
600	24	T	T		T	T

*1 : Can be used without flange drilling.

*2 : There are 2 upper drilling holes for 50mm and 80mm to 250mm types, and a total of 4 drilling holes, 2 upper and 2 lower, for 300mm to 400mm types.

D/T : With drill hole or tapping.

D : With flange drilling

T : With flange tapping

■class 300 Lugged type

Nominal size		ASME/JPI class 300	JIS20K	JIS30K	BS4504(DIN) PN25	BS4504(DIN) PN40
mm	inch					
50	2	T	T	T	T*1	T*1
80	3	T	T	T	T	T
100	4	T	T	T	T	T
150	6	T	T	T	X	X
200	8	T	T	T	T	T
250	10	T	X	X	X	X
300	12	T	T	T	T	T
350	14	T	X	X	X	X
400	16	T	X	X	X	X
450	18	T	X	X	X	X
500	20	T	X		X	X
600	24	T	T		X	X

* Please consult with us regarding drilling holes for the lugged type.

*1 Use class 150 body.

T : With flange tapping

X : A special wooden form is required.

Butterfly Valve
TRITEC
TT2
334A
344Q
302A/303Q
304A/304Q
304YA
302Y/304Y
304M (HLV)
507V/508V
DTM
846T/847T/847Q
841T/842T
700Z
700G/704G/705G
72WG/72SG/72LG
731P/732P/732Q/752W
731R
700E/700K/700S
704G/722F/720F
227P
907T/908H (MKT)
903L/901C/905C (Bata-check)

334A-class 150/300 Applicable Pipe List in Case

Nominal size		JIS (STPG)			ASME B36.1		
mm	inch	Sch#40	Sch#60	Sch#80	Sch#40	Sch#60	Sch#80
50	2	○	○	○	○	X	○
80	3	○	○	○	○		○
100	4	○	○	○	○		○
150	6	○	○	○	○		○
200	8	○	○	○	○	○	○
250	10	○	○	○	○	○	○
300	12	○	○	○	○	○	○
350	14	○	○	○	○	○	○
400	16	○	○	○	○	○	○
450	18	○	○	○	○	○	○
500	20	○	○	○	○	○	○
600	24	○	○	○	○	○	○

※ Determine the appropriateness of using other pipes according to the minimum internal pipe diameter indicated in the following table.

334A Minimum Internal Diameters of Piping

Nominal size		Minimum internal diameters of piping	
mm	inch	class 150	class 300
50	2	45	45
80	3	73	73
100	4	93	93
150	6	138	138
200	8	186	185
250	10	226	225
300	12	268	267
350	14	310	306
400	16	354	347
450	18	402	394
500	20	444	438
600	24	535	533

※ The gap between the disc edge and the pipe is smallest at the stem side flange face when all nominal sizes are fully open.

※ Because the above gap is calculated with the pipe considered as extending up to the flange end, the value will differ depending on the way the pipe and flange are welded.

334A Piping Gasket

- * In case of sheet gasket Any standard can be used.
- * In case of spiral gasket
 - For ASME, API, JPI flange Any standard gaskets with inner/outer ring can be used.
 - For JIS flange Use special spiral gasket shown below.

● 334A Special Spiral Gasket Flange Size

Nominal size		D ₁	D ₂	D ₃	D ₄								
					ASME JPI		JIS			BS4504			
					Class 150	Class 300	10K	16/20K	30K	PN10	PN16	PN25	PN40
50	2	61	69	88	104	111	104	104	114	109	109	109	109
80	3	89	97	120	136	149	134	140	150	144	144	144	144
100	4	115	124	145	174	181	159	165	172	164	164	170	170
150	6	166	178	207	222	250	220	237	249	220	220	226	226
200	8	217	227	257	279	308	270	282	294	275	275	286	293
250	10	268	282	318	339	362	332	354	360	330	331	343	355
300	12	319	339	370	409	422	377	404	418	380	386	403	420
350	14	356	369	403	450	485	422	450	463	440	446	460	477
400	16	406	420	457	514	539	484	508	524	491	498	517	549
450	18	458	472	517	549	596	539	573	—	541	558	567	574
500	20	508	523	567	606	654	594	628	—	596	620	627	631
600	24	610	626	672	717	774	700	734	—	698	737	734	750

※ Using 334A gasket for size 300, 350mm.
Using TOMOE 300 series for other.

Remark : In case a minute leakage of gas (less than 100PPm) becomes a problem, please inquire of our business charge.

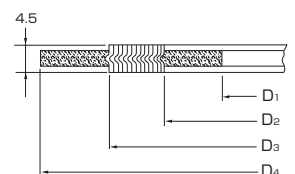

●Commercially Available Spiral Gaskets (with inner and outer ring)

Nominal size		ASME/JPI	JIS			BS4504
mm	inch	class 150/300	10K	16K/20K	30K	PN10, 16, 25, 40
50	2	○	○	○	○	○
80	3	○	○	○	×	○
100	4	○	×	○	×	○
150	6	○	×	×	×	×
200	8	○	×	×	×	×
250	10	○	×	×	×	×
300	12	○	×	○	×	×
350	14	○	×	×	×	○
400	16	○	×	×	○	○
450	18	○	×	×	—	○
500	20	○	×	×	—	○
600	24	○	×	×	—	○

○: Can be used, ×: Can not be used, —: No Standard

334A Applicable Gasket Standard Table for Piping

Nominal size		Joint sheet and RPTFE solid gasket (t≤2mm)				*PTFE mold type gasket VALQUA or NICHIASU	
		ASME/JPI	JIS		BS4504	ASME/JPI	JIS
mm	inch	class 150/300	10K, 16K, 20K	30K	PN10,16,25,40	class 150/300	10K, 16K, 20K
50	2	○	○	○	○	○	○
80	3	○	○	○	○	○	○
100	4	○	○	○	○	○	○
150	6	○	○	○	○	○	○
200	8	○	○	○	○	○	○
250	10	○	○	○	○	○	○
300	12	○	○	○	○	○	○
350	14	○	○	○	○	○	○
400	16	○	○	○	○	○	○
450	18	○	○	—	○	○	○
500	20	○	○	—	○	○	○
600	24	○	○	—	○	○	○

*All standard joint seats and PTFE cut gaskets can be used.

*Only VALQUA flawless gaskets (Part No.: 7030/7031/7035) and NICHIAS PTFE cushion gaskets (Part No.: 9010/9011) can be used. (Products from other manufacturers cannot be used due to their dimensions.)

Butterfly Valve
TRITEC
TT2
334A
344Q
302A/303Q
304A/304Q
304YA
302Y/304Y
304M (HLV)
507V/508V
DTM
846T/847T/847Q
841T/842T
700Z
700G/704G/705G
72WG/72SG/72LG
731P/732P/732Q/752W
731R
700E/700K/700S
704G/722F/720F
227P
907T/908H (MKT)
903L/901C/905C (Bata-check)

334A Piping Bolts and Nuts Sizes

■class 150 Wafer Type

Nominal size		ASME/JPI class150			JIS10K		
mm	inch	Setting Bolts	Long Bolts	No.of Nuts	Setting Bolts	Long Bolts	No.of Nuts
50	2	—	4- 5/8-11UNC×140	8	—	4-M16×135	8
80	3	—	4- 5/8-11UNC×160	8	—	8-M16×145	16
100	4	—	8- 5/8-11UNC×160	16	—	8-M16×145	16
150	6	—	8- 3/4-10UNC×175	16	—	8-M20×170	16
200	8	—	8- 3/4-10UNC×185	16	—	12-M20×180	24
250	10	—	12- 7/8-9UNC×205	24	—	12-M22×190	24
300	12	—	12- 7/8-9UNC×220	24	—	16-M22×200	32
350	14	—	12- 1-8UNC ×245	24	—	16-M22×215	32
400	16	—	16- 1-8UNC ×260	32	—	16-M24×240	32
450	18	8-1 1/8-8UN×140(24×16)	12-1 1/8-8UN ×285	32	8-M24×120(21×14)	16-M24×250	40
500	20	8-1 1-8-8UN×145(24×16)	16-1 1-8-8UN ×300	40	8-M24×120(21×14)	16-M24×260	40
600	24	8-1 1/4-8UN×150(24×16)	16-1 1/4-8UN ×345	40	8-M30×135(24×16)	20-M30×310	48

Nominal size		JIS16K			JIS20K		
mm	inch	Setting Bolts	Long Bolts	No.of Nuts	Setting Bolts	Long Bolts	No.of Nuts
50	2	—	8-M16 ×135	16	—	8-M16 ×135	16
80	3	—	8-M20 ×160	16	—	8-M20 ×160	16
100	4	—	8-M20 ×170	16	—	8-M20 ×170	16
150	6	—	12-M22 ×175	24	—	12-M22 ×190	24
200	8	—	12-M22 ×190	24	—	12-M22 ×200	24
250	10	—	12-M24 ×210	24	—	12-M24 ×220	24
300	12	—	16-M24 ×220	32	—	16-M24 ×230	32
350	14	—	16-M30(P3)×250	32	—	16-M30(P3)×260	32
400	16	—	16-M30(P3)×275	32	—	16-M30(P3)×285	32
450	18	8-M30(P3)×140(24×16)	16-M30(P3)×285	40	8-M30(P3)×150(24×16)	16-M30(P3)×300	40
500	20	8-M30(P3)×145(24×16)	16-M30(P3)×300	40	8-M30(P3)×155(24×16)	16-M30(P3)×315	40
600	24	8-M36(P3)×160(30×20)	20-M36(P3)×355	48	8-M36(P3)×170(30×20)	20-M36(P3)×365	48

Nominal size		BS4504 PN10*			BS4504 PN16*		
mm	inch	Setting Bolts	Long Bolts	No.of Nuts	Setting Bolts	Long Bolts	No.of Nuts
50	2	—	4-M16×135	8	—	4-M16×135	8
80	3	—	8-M16×145	16	—	8-M16×145	16
100	4	—	8-M16×155	16	—	8-M16×155	16
150	6	—	8-M20×170	16	—	8-M20×170	16
200	8	—	8-M20×180	16	—	12-M20×180	24
250	10	—	12-M20×190	24	—	12-M24×200	24
300	12	—	12-M20×200	24	—	12-M24×220	24
350	14	—	16-M20×210	32	—	16-M24×230	32
400	16	—	16-M24×230	32	—	16-M27×250	32
450	18	8-M24×115(21×14)	16-M24×250	40	8-M27×125(22×14)	16-M27×265	40
500	20	8-M24×115(21×14)	16-M24×260	40	8-M30×140(24×16)	16-M30×285	40
600	24	8-M27×120(22×14)	16-M27×310	40	8-M33×150(27×18)	16-M33×330	40

334A Piping Bolts and Nuts Sizes

■ class 150 Lugged Type (All taps)

Nominal size		ASME/JPI class 150		JIS10K		JIS16K	
mm	inch	Setting Bolts	No. of Nuts	Setting Bolts	No. of Nuts	Setting Bolts	No. of Nuts
50	2	8- 5/8-11UNC× 75(13× 8)	8	8-M16×75(13× 8)	8	8-M16× 75(13× 8)	8
80	3	8- 5/8-11UNC× 85(13× 8)	8	16-M16×75(13× 8)	16	16-M20× 85(17×11)	16
100	4	16- 5/8-11UNC× 85(13× 8)	16	16-M16×75(13× 8)	16	16-M20× 90(17×11)	16
150	6	16- 3/4-10UNC× 95(17×11)	16	16-M20×90(17×11)	16	—	—
200	8	16- 3/4-10UNC×100(17×11)	16	—	—	—	—
250	10	24- 7/8- 9UNC×115(19×12)	24	24-M22×105(19×12)	24	24-M24×115(21×14)	24
300	12	24- 7/8- 9UNC×115(19×12)	24	—	—	—	—
350	14	24- 1-8UNC×125(21×14)	24	—	—	—	—
400	16	32- 1-8UNC×125(21×14)	32	32-M24×115(21×14)	32	32-M30(P3)×140(24×16)	32
450	18	32-1 1/8-8UN ×140(24×16)	32	—	—	—	—
500	20	40-1 1/8-8UN ×145(24×16)	40	40-M24×125(21×14)	40	40-M30(P3)×150(24×16)	40
600	24	40-1 1/4-8UN ×160(24×16)	40	—	—	—	—

Nominal size		JIS20K		BS4504 PN10 ^{**}		BS4504 PN16 ^{**}	
mm	inch	Setting Bolts	No. of Nuts	Setting Bolts	No. of Nuts	Setting Bolts	No. of Nuts
50	2	8-M16× 75(13× 8)	8	8-M16× 75(13× 8)	8	8-M16× 75(13× 8)	8
80	3	16-M20× 85(17×11)	16	16-M16× 75(17×11)	16	16-M16× 75(13× 8)	16
100	4	16-M20× 90(17×11)	16	16-M16× 75(17×11)	16	16-M16× 75(13× 8)	16
150	6	—	—	16-M20× 90(17×11)	16	16-M20× 90(17×11)	16
200	8	—	—	16-M20× 95(17×11)	16	—	—
250	10	24-M24×125(21×14)	24	24-M20×105(17×11)	24	24-M24×115(21×14)	24
300	12	—	—	24-M20×105(17×11)	24	24-M24×115(21×14)	24
350	14	—	—	—	—	—	—
400	16	32-M30(P3)×145(24×16)	32	32-M24×115(21×14)	32	32-M27×125(22×14)	32
450	18	—	—	—	—	—	—
500	20	40-M30(P3)×155(24×16)	40	40-M24×120(21×14)	40	40-M30×140(24×16)	40
600	24	—	—	40-M27×125(22×14)	40	40-M33×150(27×18)	40

Note: Bolt/Nut material: SNB7/S45C

Please use a nut with a height that is 100% of the screw diameter.

The bolt length calculation is based on use of a 4.5 mm thick spiral gasket.

The flange thickness calculation is based on the standard steel flange thickness.

* Mark: The flange thickness calculation is based on the welding neck flange thickness.

Quantities shown are for one valve.

Examples

Setting bolts: 8 - M16 × 75 (13 × 8)

Long bolts: 4 - M16 × 145

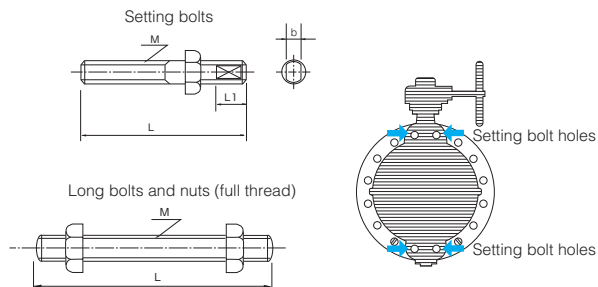

Butterfly Valve
TRITEC
TT2
334A
344Q
302A/303Q
304A/304Q
304YA
302Y/304Y
304M (HLV)
507V/508V
DTM
846T/847T/847Q
841T/842T
700Z
700G/704G/705G
72WG/72SG/72LG
731P/732P/732Q/752W
731R
700E/700K/700S
704G/722F/720F
227P
907T/908H (MKT)
903L/901C/905C (Bata-check)

334A Piping Bolts and Nuts Sizes

■class 300 Wafer

Nominal size		ASME/JPI class300			JIS20K		
mm	inch	Setting Bolts	Long Bolts	No.of Nuts	Setting Bolts	Long Bolts	No.of Nuts
50	2	—	8- 5/8-11UNC×140	16	—	8-M16 ×135	16
80	3	—	8- 3/4-10UNC×175	16	—	8-M20 ×160	16
100	4	—	8- 3/4-10UNC×185	16	—	8-M20 ×170	16
150	6	—	12- 3/4-10UNC×200	24	—	12-M22 ×190	24
200	8	—	12- 7/8-9UNC×235	24	—	12-M22 ×200	24
250	10	8-1-8UNC×130(21×14)	12- 1-8UNC×260	32	8(0)-M24 ×110(21×14)	8(12)-M24 ×230	24
300	12	8-1 1/8-8UN×130(24×16)	12-1 1/8-8UN ×285	32	8-M24 ×120(21×14)	12-M24 ×240	32
350	14	8-1 1/8-8UN×145(24×16)	16-1 1/8-8UN ×315	40	8-M30(P3)×140(24×16)	12-M30(P3)×285	32
400	16	8-1 1/4-8UN×155(24×16)	16-1 1/4-8UN ×345	40	8-M30(P3)×140(24×16)	12-M30(P3)×315	32
450	18	8-1 1/4-8UN×155(24×16)	20-1 1/4-8UN ×365	48	8-M30(P3)×145(24×16)	16-M30(P3)×335	40
500	20	8-1 1/4-8UN×160(24×16)	20-1 1/4-8UN ×380	48	8-M30(P3)×150(24×16)	16-M30(P3)×350	40
600	24	8-1 1/2-8UN×190(30×20)	20-1 1/2-8UN ×430	48	8-M36(P3)×175(30×20)	20-M36(P3)×385	48

Nominal size		JIS30K		
mm	inch	Setting Bolts	Long Bolts	No.of Nuts
50	2	—	8-M16 ×145	16
80	3	—	8-M20 ×170	16
100	4	—	8-M22 ×190	16
150	6	—	12-M24 ×210	24
200	8	—	12-M24 ×240	24
250	10	8(0)-M30(P3)×135(24×16)	8(12)-M30(P3)×275	24
300	12	8-M30(P3)×145(24×16)	12-M30(P3)×285	32
350	14	8-M30(P3)×155(24×16)	12-M30(P3)×315	32
400	16	8-M36(P3)×170(30×20)	12-M36(P3)×355	32

Nominal size		BS4504(DIN)NP25			BS4504(DIN)NP40		
mm	inch	Setting Bolts	Long Bolts	No.of Nuts	Setting Bolts	Long Bolts	No.of Nuts
50	2	—	4-M16×145	8	—	4-M16 ×145	8
80	3	—	8-M16×155	16	—	8-M16 ×155	16
100	4	—	8-M20×170	16	—	8-M20 ×170	16
150	6	—	8-M24×190	16	—	8- M24×190	16
200	8	—	12-M24×210	24	—	12-M27×230	24
250	10	8(0)-M27×115(22×14)	8(12)-M27×230	24	8(0)-M30×125(24×16)	8(12)-M30×250	24
300	12	8-M27×115(22×14)	12-M27×250	32	8-M30×125(24×16)	12-M30×270	32
350	14	8-M30×135(24×16)	12-M30×285	32	8-M33×150(27×18)	12-M33×310	32
400	16	8-M33×145(27×18)	12-M33×310	32	8-M36×160(30×20)	12-M36×340	32
450	18	8-M33×145(27×18)	16-M33×330	40	8-M36×160(30×20)	16-M36×355	40
500	20	8-M33×150(27×18)	16-M33×350	40	8-M39×170(32×21)	16-M39×375	40
600	24	8-M36×170(30×20)	16-M36×380	40	8-M45×200(36×24)	16-M45×430	40

334A Piping Bolts and Nuts Sizes

■class 300 Lugged (fully-tapped)

Nominal size		ASME/JPI class300		JIS20K		JIS30K	
mm	inch	Setting Bolts	No.of Nuts	Setting Bolts	No.of Nuts	Setting Bolts	No.of Nuts
50	2	16-5/8-11UNC×75(13× 8)	16	16-M16× 75(13× 8)	16	—	—
80	3	16-3/4-10UNC×95(17×11)	16	16-M20× 85(17×11)	16	16-M20× 90(17×11)	16
100	4	16-3/4-10UNC×95(17×11)	16	16-M20× 90(17×11)	16	16-M22×105(19×12)	16
150	6	24-3/4-10UNC×100(17×11)	24	24-M22×100(19×12)	24	24-M24×115(21×14)	24
200	8	24-7/8-9UNC×115(19×12)	24	24-M22×105(19×12)	24	24-M24×120(21×14)	24
250	10	32- 1-8UNC×130(21×14)	32	—	—	—	—
300	12	32-1 1/8-8UN×145(24×16)	32	32-M24×120(21×14)	32	32-M30(P3)×145(24×16)	32
350	14	40-1 1/8-8UN×155(24×16)	40	—	—	—	—
400	16	40-1 1/4-8UN×160(24×16)	40	—	—	—	—
450	18	48-1 1/4-8UN×165(24×16)	48	—	—	—	—
500	20	48-1 1/4-8UN×170(24×16)	48	—	—	—	—
600	24	48-1 1/2-8UN×200(30×20)	48	48-M36(P3)×180(30×20)	48	—	—

Nominal size		BS4504(DIN)NP25*		BS4504(DIN)NP40*	
mm	inch	Setting Bolts	No.of Nuts	Setting Bolts	No.of Nuts
50	2	8-M16× 75(13× 8)	8	8-M16× 75(13× 8)	8
80	3	16-M16× 75(13× 8)	16	16-M16× 75(13× 8)	16
100	4	16-M20× 90(17×11)	16	16-M20× 90(17×11)	16
150	6	—	—	—	—
200	8	24-M24×115(21×14)	24	24-M27×120(22×14)	24
250	10	—	—	—	—
300	12	32-M27×120(24×14)	32	32-M30×140(24×16)	32
350	14	—	—	—	—
400	16	—	—	—	—
450	18	—	—	—	—
500	20	—	—	—	—
600	24	—	—	—	—

Note: Bolt/Nut material: SNB7/S45C

Please use a nut with a height that is 100% of the screw diameter.

The bolt length calculation is based on use of a 4.5 mm thick spiral gasket.

The flange thickness calculation is based on the standard steel flange thickness.

Quantities shown are for one valve.

250 mm bolt quantities are indicated as follows: The quantity outside the brackets applies when the setting bolt holes are tapped and the values inside the brackets apply when the setting bolt holes are drilled.

※ The flange thickness calculation is based on the welding neck flange thickness. Quantities shown are for one valve.

Examples

Setting bolts: 8 - M16 × 75 (13 × 8)
 | | | | |
 N M L b L1

Long bolts: 4 - M16 × 145
 | | |
 N M L

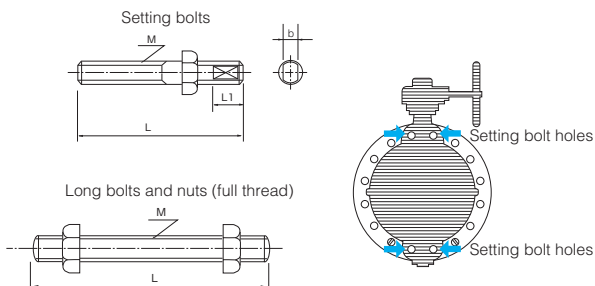

Butterfly Valve
TRITEC
TT2
334A
344Q
302A/303Q
304A/304Q
304YA
302Y/304Y
304M (HLV)
507V/508V
DTM
846T/847T/847Q
841T/842T
700Z
700G/704G/705G
72WG/72SG/72LG
731P/732P/732Q/752W
731R
700E/700K/700S
704G/722F/720F
227P
907T/908H (MKT)
903L/901C/905C (Bata-check)