

High Performance Butterfly Valves
to Suit API Standard class 150 Rating

Tom Disco

304A Wafer

304Q Lugged

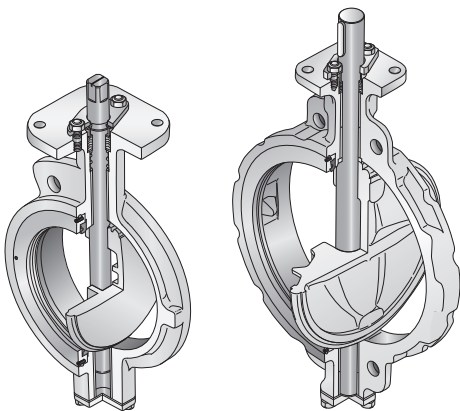
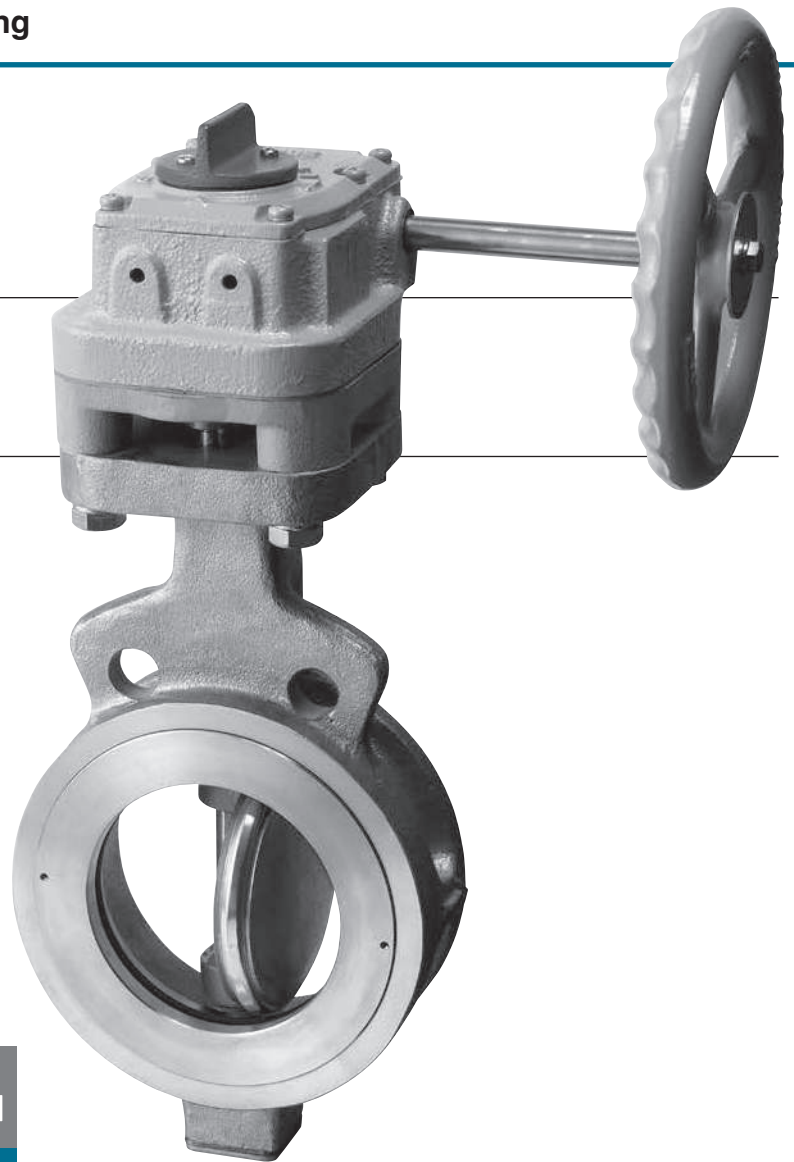

80mm to 300mm

350mm to 600mm

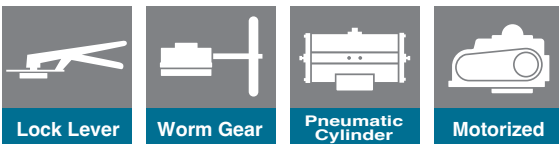

Lock Lever

Worm Gear

Pneumatic
Cylinder

Motorized

Features and Benefits

Unique stopper structure

For the 80 to 300mm models, automatic aligning and disc overrun prevention are ensured by the special spherical design of the inner surface of the body disc hub edge. As for the 350 to 600mm models, a spacer ring is provided between the mating surfaces of the disc hub edge and inner surface of the body for disc alignment.

Disc overrun is prevented by a protrusion on the inner surface of the body.

Double eccentric geometry

The axis of disc rotation is double offset to the seat ring. When the disc rotates, it unseats at a small turning angle by its cam effect. The design exhibits tight shut-off, reduced torques, chemical resistance, excellent throttling capabilities and the ability to operate with relatively high pressure drops. It also prevents seat abrasion and provides reliable sealing performance over long periods.

Bi-directional flow

Seals flow in both directions. The valves can be used even if the flow changes direction. (There are pressure limitations for each direction of flow. See chart for recommended specifications).

Easy replacement of the seat ring

The ball lock method is used to simplify replacement of the seat ring.

General Description

Designed to suit those severe conditions such as high temperature, high pressure or high velocity, which disallow the use of soft resilient seated butterfly valves. Ideal for use in chemical processes and applications with low pressure steam and high temperature gas.

Seat Structure

80mm to 300mm

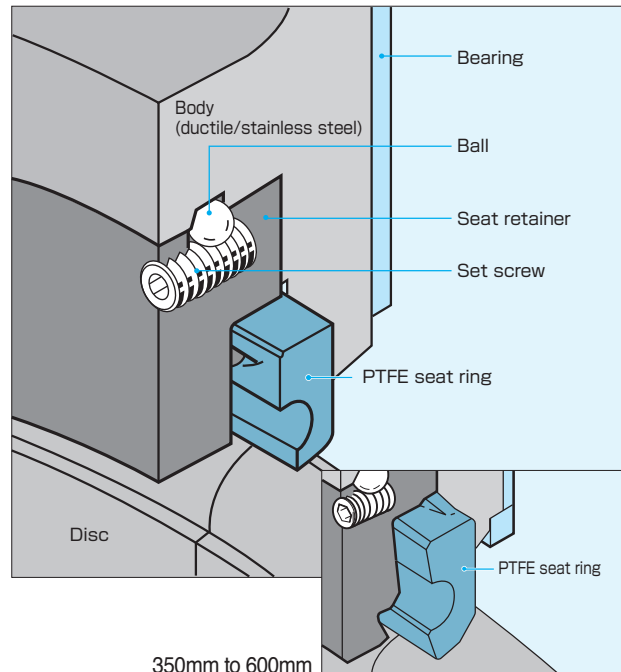

350mm to 600mm

Standard Specifications

Valve nominal size**1	80mm to 300mm		350mm to 600mm (5 sizes)		
Face-to-face dimensions	API 609 (class 150) JPI-7S-83(class 150) ※125mm is as per JIS B 2002(series 46)/ISO 5752(series 20)		API 609 (class 150), JPI-7S-83(class 150) ISO 5752 (25 series), JIS B 2002 (47 series)		
Connection	Wafer type / Lugged type (option: flanged type)				
Pressure rating	ASME B16.34 Class 150 (350mm and over: Seat rating is designed to suit API 609 Class 150 above zero degree C)				
Flange accommodation	JIS 10K/16K/20K, ASME Class 125/150, API/JPI Class 150, BS 10 Table F, BS 4504 PN 10/16, DIN PN 10/16		JIS 5K/10K/16K/20K, ASME Class 125/150, API/JPI Class 150, BS 10 Table F, BS 4504 PN 10/16, DIN PN 10/16		
Body shell test	Max 3.1MPa as per API 598 by hydraulic				
Seat leak test	0.7MPa as per API 598 by Air. High pressure closure test is available upon request.				
Max. working pressure**2	2.0MPa				
	Bi-directional flow (Flow to disc side is recommended.)				
	Max. working pressure at reverse flow: 2.0MPa (80mm to 200mm) 1.6MPa (250mm and 300mm)		Max. working pressure at reverse flow:Please consult us.		
Working temperature range	-29 to 232 degrees C (RPTFE)		-20 to 232 degrees C (RPTFE)		
Seat leakage	-20 to 200 degrees C (D.PTFE as option)				
Standard materials**3	ISO 5208 rate A, API 598-1996				
	Body	SCPH2/WCB	SCS 14A/CF8M	SCPH 2/WCB	SCS 13A/CF8
	Disc	SCS 13A/CF8 (Hard chrome plating)	SCS 16A/CF3M (Hard chrome plating)	SCS13A/CF8 (Hard chrome plating)	
	Stem	SUS 420 J2	SUS 329 J1 SUS 316 L SUS 329 J4 L	SUS 420 J2 SUS 630	SUS 304 SUS 630
	Seat ring	RPTFE as standard, D.PTFE as an option			
Gland packing	RPTFE		Graphite		
Top flange	ISO 5211				
Bonnet type	Open bonnet				
Actuators	Lock lever	80 to 150mm			
	Worm gear				
	Pneumatic cylinder	80 to 600mm			
	Motorized				
Coating	Silicon resin coating (Grey N7) for 200 degrees C or lower. Heat resistant silver coating for over 200 degrees C. No painting for stainless steel.				

※1 304Y is available for 50mm and 65mm.

※2 Please consult us if the pressure exceeds 1.6MPa.

※3 Please refer to the pressure rating chart and stem material chart in the following pages. Other materials are available. Please consult us.

※ It is possible that seat leakage occur when fluid (e.g. powder and/or liquid) is solidified by working temperature and other cause. Consult us.
Please note that use with vertical line such as bottom area of discharge spout of hopper, and tank.

Butterfly Valve

TRITEC

TT2

334A

344Q

302A/303Q

304A/304Q

304YA

302Y/304Y

304M

(HLV)

507V/508V

DTM

846T/847T/847Q

841T/842T

700Z

700G/704G/705G

72WG/72SG/72LG

731P/732P/

732Q/752W

731R

700E/700K/700S

704G/722F/720F

227P

907T/908H

(MKT)

903L/901C/

905C (Bata-check)

Tom Disco 304A (Wafer) / 304Q (Lugged)

304A Expanded view of components

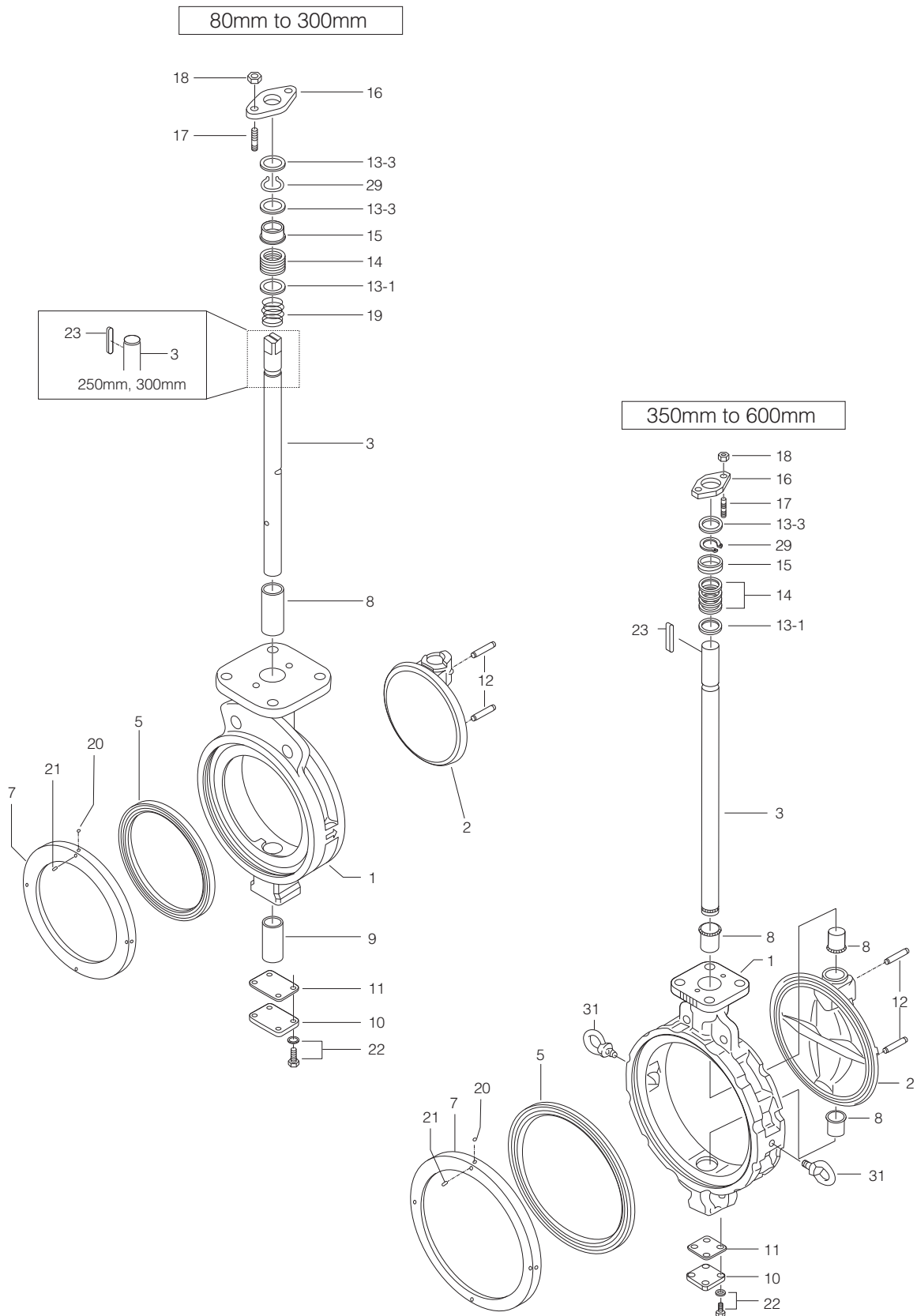

304A Parts List

■ 304A Parts List (80mm to 300mm)

No.	Description	Q'ty	Remarks
1	Body	1	
2	Disc	1	
3	Stem	1	
★ 5	Seat ring	1	
7	Seat ring retainer	1	
8	Top shaft bearing	1	
9	Bottom shaft bearing	1	
10	Bottom cover	1	
★ 11	Bottom gasket	1	
12	Taper pin	2	
13-1	Packing retainer	1	
13-3	Ring	2	
★ 14	Gland packing	1 set	
15	Gland bush	1	
16	Gland flange	1	
17	Gland bolt	2	
18	Gland nut	2	
19	Gland coil	1	Only 80mm to 150mm
★ 20	Ball	2	80mm to 125mm
		4	150mm to 300mm
★ 21	Set screw	2	80mm to 125mm
		4	150mm to 300mm
22	Hexagon bolt, Spring washer	4 sets	
23	Stem key	1	Only 250mm, 300mm
29	C-ring	1	

■ 304A Parts List (350mm to 600mm)

No.	Description	Q'ty	Remarks
1	Body	1	
2	Disc	1	
3	Stem	1	
★ 5	Seat ring	1	
7	Seat ring retainer	1	
8	Shaft bearing	3	
10	Bottom cover	1	
★ 11	Bottom gasket	1	
12	Taper pin	1	
13-1	Packing retainer	1	
13-3	Ring	1	
★ 14	Gland packing	1 set	
15	Gland bush	1	
16	Gland flange	1	
17	Gland bolt	2	
18	Gland nut	2	
★ 20	Ball	4	
★ 21	Set screw	4	
22	Hexagon bolt, Spring washer	4 sets	
23	Stem key	1	
29	C-ring	1	
31	Eye bolt	2	Only 450mm to 600mm

Remark: The ★ indicates recommended spare parts. They are supplied as "Seat ring set" with a small hexagonal spanner to remove set screws (Part #21 Set screw).

Butterfly Valve
TRITEC
TT2
334A
344Q
302A/303Q
304A/304Q
304YA
302Y/304Y
304M (HLV)
507V/508V
DTM
846T/847T/847Q
841T/842T
700Z
700G/704G/705G
72WG/72SG/72LG
731P/732P/732Q/752W
731R
700E/700K/700S
704G/722F/720F
227P
907T/908H (MKT)
903L/901C/905C (Bata-check)

Tom Disco 304A (Wafer)/304Q (Lugged)

304A Actuator selection chart

80mm to 300mm

Model	Category	Size (mm/inch)						
		80	100	125	150	200	250	300
		3	4	5	6	8	10	12
1T	T10	1T-2		1T-3				
	T20	1T-2		1T-3				
2U	T10	2U-2		2U-4		2U-5		
	T20	2U-2		2U-4		2U-5		
7E	T10	T85	T200		T380	T750		
	T20	T85	T200		T380	T750		
7G,7F 3U,3K	T10	T200S	T380S		T750S		TG-12S	
	T20	T200S	T380S		T750S		TG-12S	
4I	T10	4I-0	4I-1	4I-2		4I-2.5	4I-3	
	T20	4I-0	4I-1	4I-2		4I-2.5	4I-3	
4J	T10	SRJ-010		SRJ-020		SRJ-060		
	T20	SRJ-010		SRJ-020		SRJ-060		

304A Pressure rating

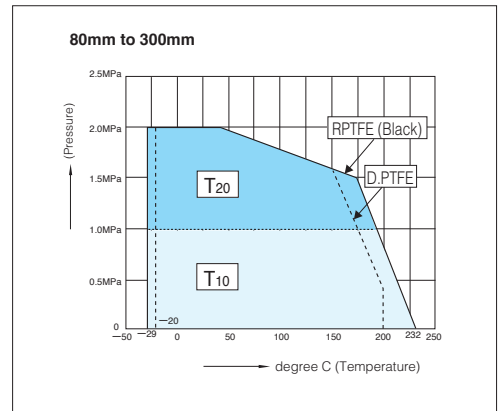

304A Standard stem material

80mm to 300mm

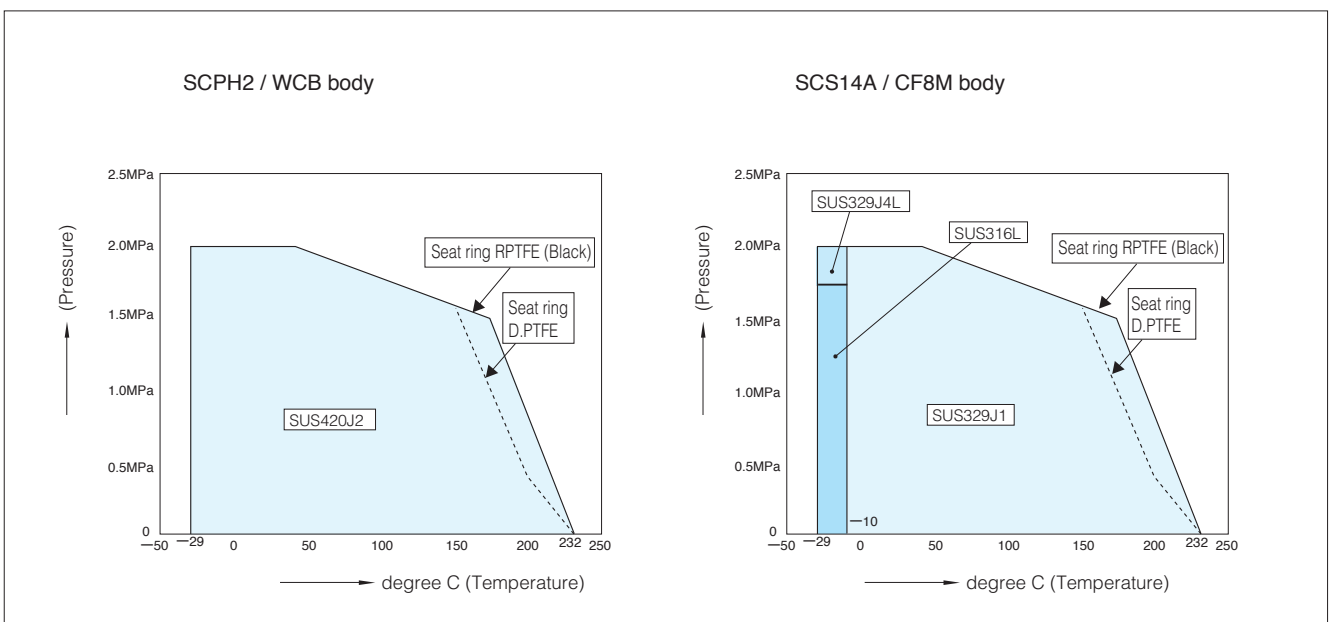

304A Actuator selection chart

350mm to 600mm

Model	Category	Size (mm / inch)				
		350	400	450	500	600
		14	16	18	20	24
2S	A	DGH-3	DGH-4	DGH-4+R/G5		
	B			DGH-4.5		
	C			DGH-4+R/G5		
3A	A	TGA-125	TGA-140	TGA-180		
	B	TGA-140	TGA-160	TGA-200		
	C		TGA-180	TGA-220		
3U,3K	A	TG-14S	TG-20S			
	B					
	C					
4I	A	4I-4				
	B					
	C					
4L	A	LTKD-01 0.2kW/DGH-3	LTKD-02 0.4kW/DGH-4	LTKD-02 1.5kW/DGH-4		
	B	LTKD-02 0.4kW/DGH-4		LTKD-02 1.5kW/DGH-4	LTKD-05 1.5kW/DGH-5	
	C	LTKD-02 0.4kW/DGH-4	LTKD-02 0.75kW/DGH-4			

304A Pressure rating

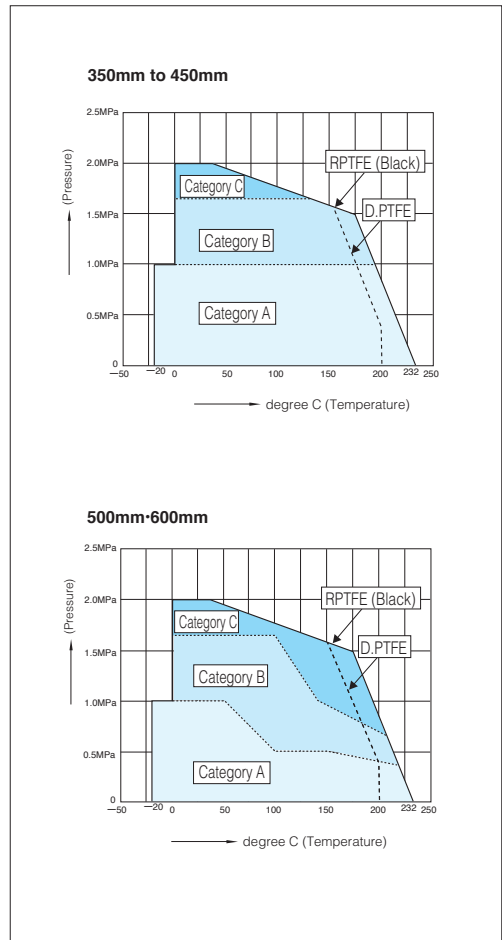

Butterfly Valve
TRITEC
TT2
334A
344Q
302A/303Q
304A/304Q
304YA
302Y/304Y
304M (HLV)
507V/508V
DTM
846T/847T/847Q
841T/842T
700Z
700G/704G/705G
72WG/72SG/72LG
731P/732P/732Q/752W
731R
700E/700K/700S
704G/722F/720F
227P
907T/908H (MKT)
903L/901C/905C (Bata-check)

304A Standard stem material

350mm to 600mm

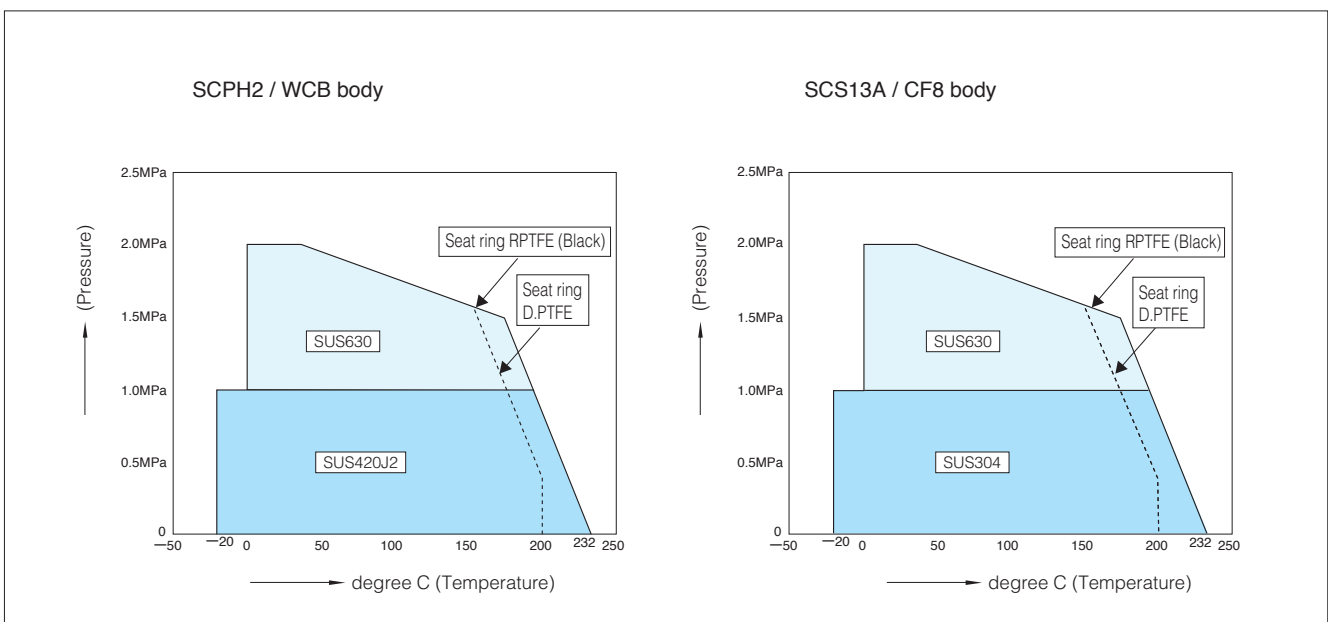

Tom Disco 304A (Wafer)/304Q (Lugged)

Dimension List

Wafer type 304A

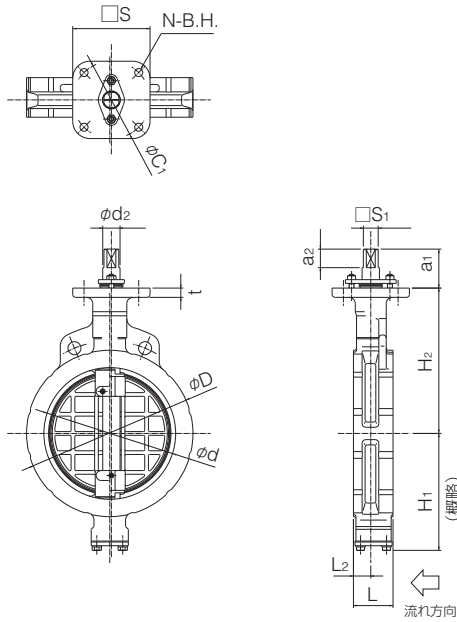

Lugged type 304Q

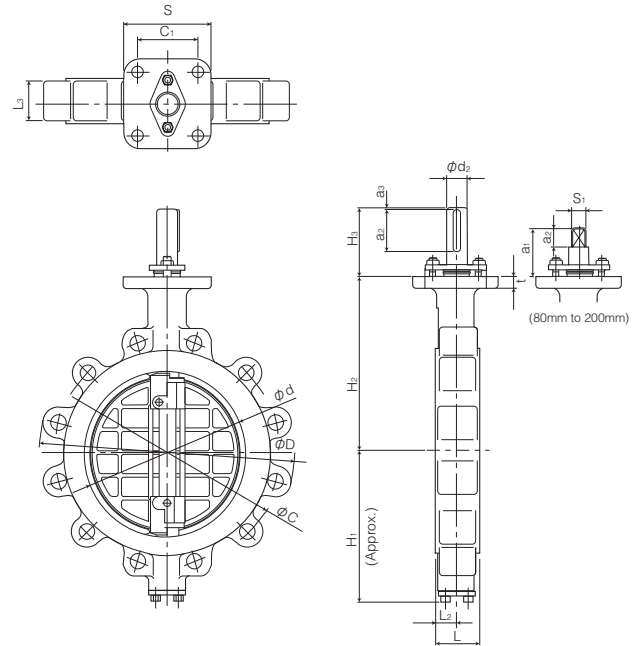

304A Dimension List

Stem shape	Nominal size		Dimension (mm)													ISO 5211 Top Flange	Approx. Weight (kg)
	mm	inch	ϕd	ϕD	L	L ₂	H ₁	H ₂	a ₁	a ₂	$\square S_1$	ϕd_2	b	t ₂	t		
01	80	3	89	127	48	23	95	147	52.5	16.5	14	16	—	—	15	F10	5
	100	4	112	156	54	24	110	170	52.5	16.5	14	16	—	—	15	F10	6.2
	125	5	137	185	56	24	139	185	52.5	16.5	16	20	—	—	15	F10	9.3
	150	6	163	216	57	23	164	205	55.5	20	18	22	—	—	15	F12	12.5
	200	8	213	269	64	28	190	235	63	30	24	28	—	—	15	F12	19
02	250	10	263	330	71	31	236	283	108	65.3	—	32	10	3	18	F14	33
	300	12	315	381	81	35	246	310	111	70.3	—	35	10	3	18	F14	42
	350	14	350	416	92	39.5	308	340	113	70	—	38	10	3	18	F14	61
	400	16	400	475	102	39	348	372	113	70	—	42	12	3.5	18	F14	88
	450	18	450	534	114	43	366	406	141.5	60	—	45	12	3.5	20	F16	135
	500	20	500	589	127	50	405	442	141.5	70	—	49	14	4	20	F16	173
600	24	600	693	154	64	461	493	141.5	70	—	59	16	5	20	F16	272	

Top Flange Dimension

ISO 5211 Top Flange	$\square S$	ϕC_1	N	B.H.
F10	102	102	4	11
F12	125	125	4	13
F14	140	140	4	19
F16	165	165	4	23

Stem shape	01 : square 02 : round with key
------------	------------------------------------

304Q Dimension List

Nominal size		Dimension (mm)														Approx. Weight (kg)		
mm	inch	ϕd	ϕD	L	L ₂	L ₃	H ₁	H ₂	H ₃	ϕd_2	a ₂	a ₃	S ₁	S	t		C ₁	ϕC
80	3	89	189	48	23	38	95	147	52.5	16	16.5	—	14	102	15	72	152.5	6
100	4	112	227	54	24	46	120	170	52.5	16	16.5	—	14	102	15	72	190.5	9.5
125	5	137	256	56	24	48	139	185	52.5	20	16.5	—	16	102	15	72	216	14
150	6	163	282	57	23	49	164	205	55.5	22	20	—	18	125	15	88.4	241.5	16
200	8	213	343	64	28	54	190	235	63	28	30	—	24	125	15	88.4	298.5	24
250	10	263	412	71	31	61	236	283	108	32	65	2	—	140	18	99	362	41
300	12	315	482	81	35	71	246	310	111	35	70	2	—	140	18	99	432	56
350	14	350	536	92	39.5	70	308	340	113	38	70	2	—	140	18	99	476.2	85
400	16	400	600	102	39	75	348	372	113	42	70	2	—	140	18	99	539.7	125
450	18	450	636	114	43	83	366	406	141.5	45	60	8	—	165	20	116.7	577.8	170
500	20	500	720	127	50	90	405	442	141.5	49	70	9	—	165	20	116.7	635	225
600	24	600	814	154	64	131	461	493	141.5	59	70	10	—	165	20	116.7	749.3	350

Lock lever type 304A-1T(80mm to 150mm)

Nominal size		Dimension (mm)									Lever type	Approx. Mass (kg)
mm	inch	ϕd	ϕD	L	L ₂	H ₁	H ₂	Category	H ₃	W		
80	3	89	127	48	23	95	147	T ₁₀ , T ₂₀	117	300	1T-2	7.1
100	4	112	156	54	24	110	170	T ₁₀ , T ₂₀	117	300	1T-2	8.3
125	5	137	185	56	24	139	185	T ₁₀ , T ₂₀	117	300	1T-2	11.4
150	6	163	216	57	23	164	205	T ₁₀ , T ₂₀	125	350	1T-3	14.6

■ 304A-1T

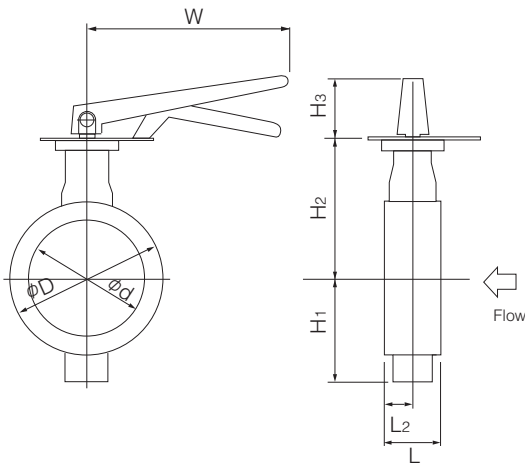

■ 1T Installation direction

<p>Retainer side</p> <p>Stem side</p> <p>1TA</p>	<p>Retainer side</p> <p>Stem side</p> <p>1TB</p>	<p>Retainer side</p> <p>Stem side</p> <p>1TC</p>	<p>Retainer side</p> <p>Stem side</p> <p>1TD</p>
---	---	---	---

Butterfly Valve

TRITEC

TT2

334A

344Q

302A/303Q

304A/304Q

304YA

302Y/304Y

304M

(HLV)

507V/508V

DTM

846T/847T/847Q

841T/842T

700Z

700G/704G/705G

72WG/72SG/72LG

731P/732P/

732Q/752W

731R

700E/700K/700S

704G/722F/720F

227P

907T/908H

(MKT)

903L/901C/

905C(Bata-check)

Tom Disco 304A (Wafer) / 304Q (Lugged)

Worm gear type 304A-2U (80mm to 300mm) / 304A-2S (350mm to 600mm)

Nominal size		Dimension (mm)												Gear type	Approx. Mass (kg)
mm	inch	ϕd	ϕD	L	L ₂	H ₁	H ₂	Category	H ₃	E	K	F	ϕW		
80	3	89	127	48	23	95	147	T ₁₀ , T ₂₀	61	44	53	173.5	160	2U-2	7.9
100	4	112	156	54	24	110	170	T ₁₀ , T ₂₀	61	44	53	173.5	160	2U-2	9.1
125	5	137	185	56	24	139	185	T ₁₀ , T ₂₀	61	44	53	173.5	160	2U-2	12.4
150	6	163	216	57	23	164	205	T ₁₀ , T ₂₀	77.5	87.5	90	222.5	200	2U-4	29
200	8	213	269	64	28	190	235	T ₁₀ , T ₂₀	77.5	87.5	90	222.5	200	2U-4	35.5
250	10	263	330	71	31	236	283	T ₁₀ , T ₂₀	90	87.5	90	222.5	280	2U-4	49.5
300	12	315	381	81	35	246	310	T ₁₀ , T ₂₀	92	90	105	266	280	2U-5	64
350	14	350	416	92	39.5	308	340	A, B, C	97	117	164	335	355	DGH-3	99
400	16	400	475	102	39	348	372	A	97	117	164	335	355	DGH-3	124
								B, C	215	140	198	402	450	DGH-4	162
450	18	450	534	114	43	366	406	A, B	127	140	198	402	450	DGH-4	198
								C	127	140	198	432	355	DGH-4+R/G5	200
500	20	500	589	127	50	405	442	A, B	127	140	198	402	450	DGH-4	236
								C	127	140	198	432	355	DGH-4+R/G5	238
600	24	600	693	154	64	461	493	A	127	140	198	432	355	DGH-4+R/G5	338
								B, C	245	185	264	497	355	DGH-4.5+R/G5	413

304A-2U/2S

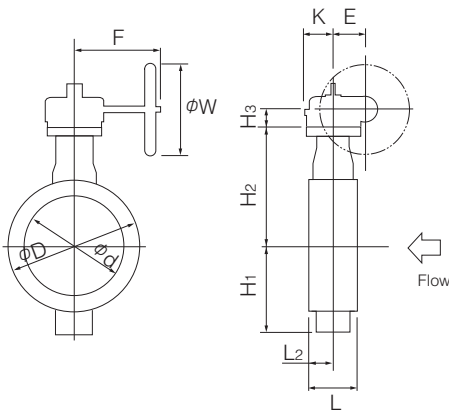

2U/2S Installation direction

<p>Retainer side</p> <p>Flow</p> <p>Stem side</p>	<p>Retainer side</p> <p>Flow</p> <p>Stem side</p>	<p>Retainer side</p> <p>Flow</p> <p>Stem side</p>	<p>Retainer side</p> <p>Flow</p> <p>Stem side</p>
2UA/2SA	2UB/2SB	2UC/2SC	2UD/2SD

Double-acting pneumatic cylinder type 304A-7E (80mm to 300mm)

Nominal size		Dimension (mm)													Cylinder type	Approx. Mass (kg)
mm	inch	ϕd	ϕD	L	L ₂	H ₁	H ₂	Category	H ₃	H ₄	A	P	f ₁	f ₂		
80	3	89	127	48	23	95	147	T ₁₀ ,T ₂₀	168	26.5	276	142	75	47	T85	11
100	4	112	156	54	24	110	170	T ₁₀	168	26.5	276	142	75	47	T85	12
								T ₂₀	203	26.5	346	176	79	57	T200	16
125	5	137	185	56	24	139	185	T ₁₀ ,T ₂₀	203	26.5	346	176	79	57	T200	19
150	6	163	216	57	23	164	205	T ₁₀ ,T ₂₀	203	29.5	346	176	79	57	T200	23
200	8	213	269	64	28	190	235	T ₁₀ ,T ₂₀	231	29.5	423	214	91	69	T380	35
250	10	263	330	71	31	236	283	T ₁₀	231	190	423	214	91	87.5	T380	63
								T ₂₀	269	190	546	270	118	87.5	T750	73
300	12	315	381	81	35	246	310	T ₁₀ ,T ₂₀	269	190	546	270	118	87.5	T750	82

304A-7E

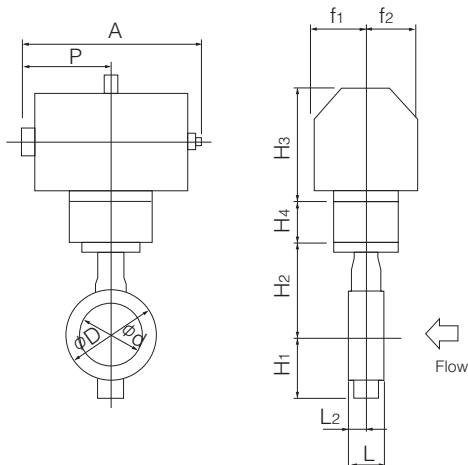

7E Installation direction

<p style="text-align: center;">7EA</p>	<p style="text-align: center;">7EB</p>	<p style="text-align: center;">7EC</p>	<p style="text-align: center;">7ED</p>
--	--	--	--

Butterfly Valve
TRITEC
TT2
334A
344Q
302A/303Q
304A/304Q
304YA
302Y/304Y
304M (HLV)
507V/508V
DTM
846T/847T/847Q
841T/842T
700Z
700G/704G/705G
72WG/72SG/72LG
731P/732P/732Q/752W
731R
700E/700K/700S
704G/722F/720F
227P
907T/908H (MKT)
903L/901C/905C (Bata-check)

Tom Disco 304A (Wafer) / 304Q (Lugged)

Double-acting pneumatic cylinder type 304A-3A (350mm to 600mm)

Nominal size		Dimension (mm)												Cylinder type	Approx. Mass (kg)
mm	inch	ϕd	ϕD	L	L ₂	H ₁	H ₂	Category	H ₃	A	P	f ₁	f ₂		
350	14	350	416	92	39.5	308	340	A	424	743	381	100	164	TGA-125	110
								B,C	472	810	432	100	180	TGA-140	121
400	16	400	475	102	39	348	372	A	424	743	381	100	164	TGA-125	136
								B	472	810	432	100	180	TGA-140	147
								C	510	939	483	130	202	TGA-160	214
450	18	450	534	114	43	366	406	A	502	810	432	100	180	TGA-140	207
								B,C	530	939	483	130	202	TGA-160	263
500	20	500	589	127	50	405	442	A	502	810	432	100	180	TGA-140	246
								B	530	939	483	130	202	TGA-160	302
								C	543	1069	543	130	218	TGA-180	330
600	24	600	693	154	64	461	493	A	543	1069	543	130	218	TGA-180	431
								B	610	1175	599	160	253	TGA-200	475
								C	640	1263	642	160	270	TGA-220	535

304A-3A

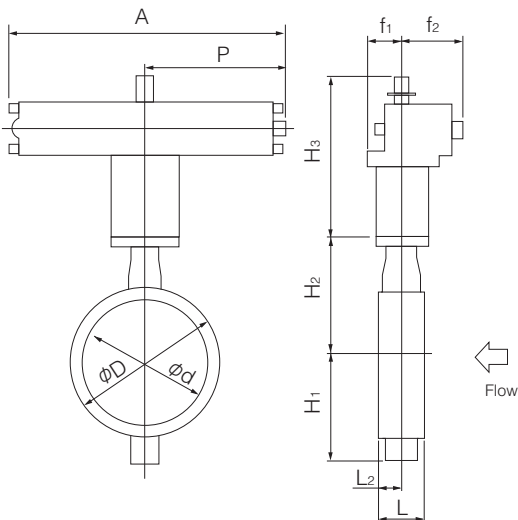

3A Installation direction

<p>Retainer side</p> <p>Stem side</p> <p>3 A A</p>	<p>Retainer side</p> <p>Stem side</p> <p>3 A B</p>	<p>Retainer side</p> <p>Stem side</p> <p>3 A C</p>	<p>Retainer side</p> <p>Stem side</p> <p>3 A D</p>
--	--	--	--

Single-acting pneumatic cylinder type 304A-7G (Air to open: 80mm to 200mm) / 304A-7F (Air to close: 80mm to 200mm)

Nominal size		Dimension (mm)												Cylinder type	Approx. Mass (kg)	
mm	inch	ϕd	ϕD	L	L ₂	H ₁	H ₂	Category	H ₃	H ₄	A	P	f ₁			f ₂
80	3	89	127	48	23	95	147	T ₁₀ , T ₂₀	203	26.5	449	226	79	57	T200S	17
100	4	112	156	54	24	110	170	T ₁₀	203	26.5	449	226	79	57	T200S	18
								T ₂₀	231	26.5	550	276	91	69	T380S	27
125	5	137	185	56	24	139	185	T ₁₀	231	26.5	550	276	91	69	T380S	30
								T ₂₀	269	26.5	723	360	118	85	T750S	43
150	6	163	216	57	23	164	205	T ₁₀ , T ₂₀	269	29.5	723	360	118	85	T750S	47
200	8	213	269	64	28	190	235	T ₁₀	269	29.5	723	360	118	85	T750S	54

304A-7F

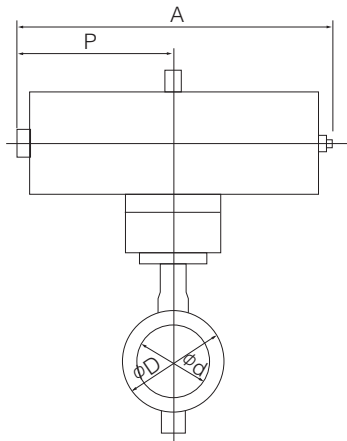

304A-7G

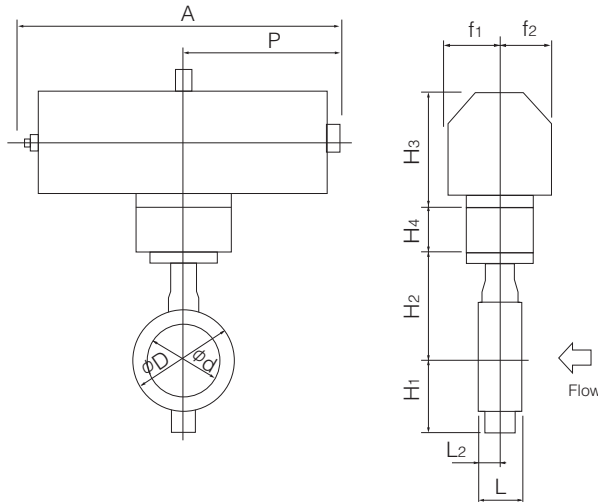

7F Installation direction

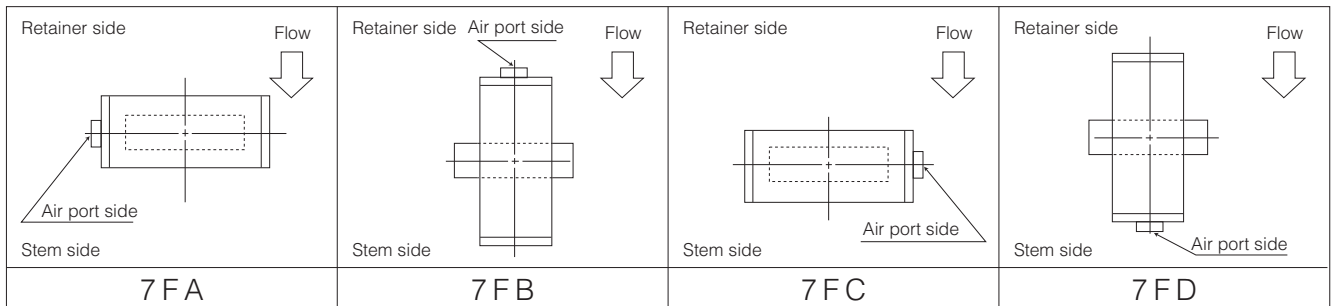

7G Installation direction

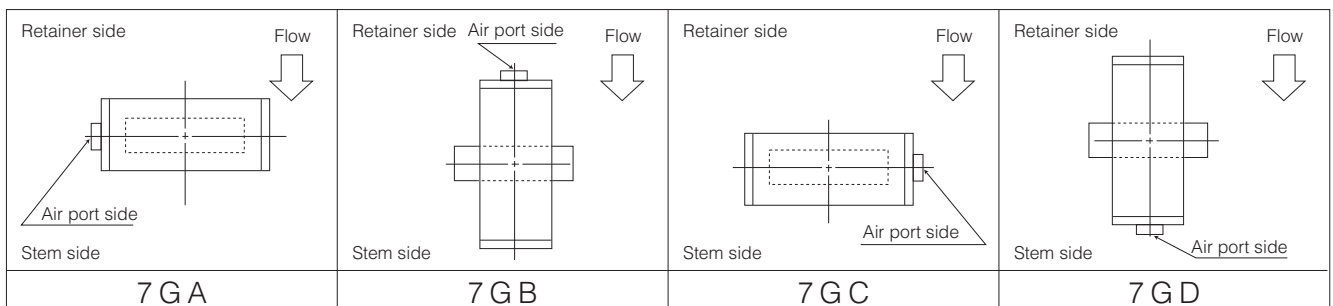

Butterfly Valve

TRITEC

TT2

334A

344Q

302A/303Q

304A/304Q

304YA

302Y/304Y

304M (HLV)

507V/508V

DTM

846T/847T/847Q

841T/842T

700Z

700G/704G/705G

72WG/72SG/72LG

731P/732P/732Q/752W

731R

700E/700K/700S

704G/722F/720F

227P

907T/908H (MKT)

903L/901C/905C (Bata-check)

Tom Disco 304A (Wafer) / 304Q (Lugged)

Single-acting pneumatic cylinder type 304A-3U (Air to open: 200mm to 600mm) / 304A-3K (Air to close: 200mm to 600mm)

Nominal size		Dimension (mm)												Cylinder type	Approx. Mass (kg)
mm	inch	ϕd	ϕD	L	L ₂	H ₁	H ₂	Category	H ₃	A	P	f ₁	f ₂		
200	8	213	269	64	28	190	235	T ₁₀	377	945	585	75	165	TG-10S	78
								T ₂₀	377	1080	720	94	206	TG-12S	123
250	10	263	330	71	31	236	283	T ₁₀ , T ₂₀	417	1080	720	94	206	TG-12S	138
300	12	315	381	81	35	246	310	T ₁₀ , T ₂₀	417	1080	720	94	206	TG-12S	147
350	14	350	416	92	39.5	308	340	A	450	1255	865	131	257	TG-14S	264
								B, C	602	1655	1095	164	348	TG-20S	485
400	16	400	475	102	39	348	372	A	450	1255	865	131	257	TG-14S	292
								B, C	602	1655	1095	164	348	TG-20S	512
450	18	450	534	114	43	366	406	A, B, C	624	1655	1095	164	348	TG-20S	564
500	20	500	589	127	50	405	442	A, B, C	624	1655	1095	164	348	TG-20S	602
600	24	600	693	154	64	461	493	A	624	1655	1095	164	348	TG-20S	701

304A-3K

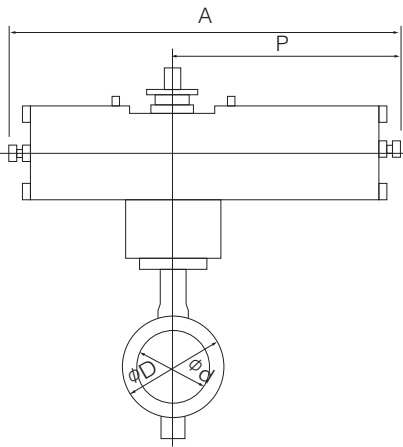

304A-3U

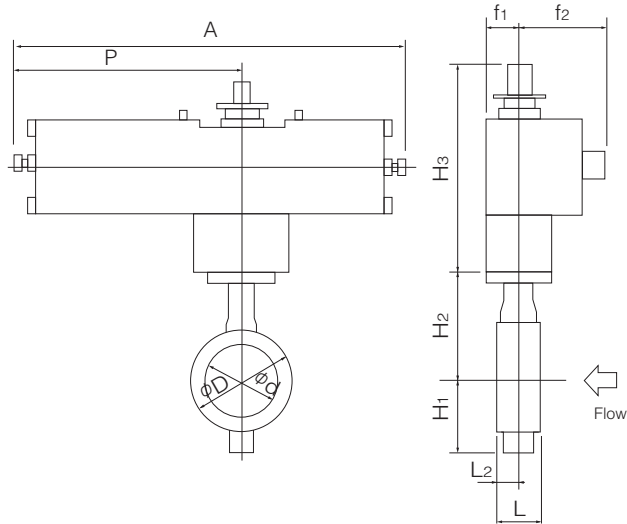

3K Installation direction

<p>Retainer side</p> <p>Stem side</p> <p>Flow</p>	<p>Retainer side</p> <p>Stem side</p> <p>Flow</p>	<p>Retainer side</p> <p>Stem side</p> <p>Flow</p>	<p>Retainer side</p> <p>Stem side</p> <p>Flow</p>
3 K A	3 K B	3 K C	3 K D

3U Installation direction

<p>Retainer side</p> <p>Stem side</p> <p>Flow</p>	<p>Retainer side</p> <p>Stem side</p> <p>Flow</p>	<p>Retainer side</p> <p>Stem side</p> <p>Flow</p>	<p>Retainer side</p> <p>Stem side</p> <p>Flow</p>
3 U A	3 U B	3 U C	3 U D

Single phase electric motor type 304A-4 I (80mm to 400mm)

Nominal size		Dimension (mm)											Motor type	Approx. Mass (kg)	
mm	inch	ϕd	ϕD	L	L ₂	H ₁	H ₂	Category	H ₃	A	P	F			K
80	3	89	127	48	23	95	147	T ₁₀ , T ₂₀	276	202	100	85	54	4 I-0	12.1
100	4	112	156	54	24	110	170	T ₁₀	265	252	138	126	65	4 I-1	15.5
								T ₂₀	298	310	167	154	85	4 I-2	21.5
125	5	137	185	56	24	139	185	T ₁₀ , T ₂₀	298	310	167	154	85	4 I-2	24.5
150	6	163	216	57	23	164	205	T ₁₀ , T ₂₀	373	310	167	154	85	4 I-2	29.5
200	8	213	269	64	28	190	235	T ₁₀ , T ₂₀	373	310	167	154	85	4 I-2.5	39
250	10	263	330	71	31	236	283	T ₁₀	411	310	167	154	85	4 I-2.5	56.5
								T ₂₀	420	388	223	246	136	4 I-3	66
300	12	315	381	81	35	246	310	T ₁₀ , T ₂₀	420	388	223	246	136	4 I-3	75
350	14	350	416	92	39.5	308	340	A, B	448	388	223	246	136	4 I-4	96
400	16	400	475	102	39	348	372	A	448	388	223	246	136	4 I-4	123

Butterfly Valve
TRITEC
TT2
334A
344Q
302A/303Q
304A/304Q
304YA
302Y/304Y
304M (HLV)
507V/508V
DTM
846T/847T/847Q
841T/842T
700Z
700G/704G/705G
72WG/72SG/72LG
731P/732P/732Q/752W
731R
700E/700K/700S
704G/722F/720F
227P
907T/908H (MKT)
903L/901C/905C (Bata-check)

■ 304A-4 I

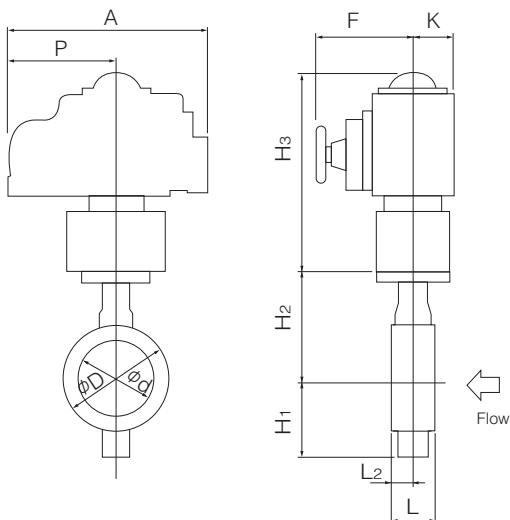

■ 4I Installation direction

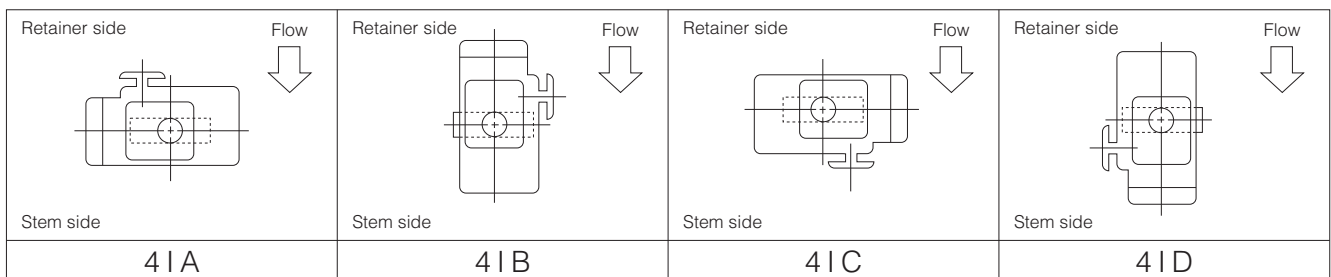

Tom Disco 304A (Wafer) / 304Q (Lugged)

Three phase motor actuator type 304A-4L (350mm to 600mm)

Nominal size		Dimension (mm)													Motor type	Approx. Mass (kg)
mm	inch	ϕd	ϕD	L	L ₂	H ₁	H ₂	Category	H ₃	E	K	F	M	P		
350	14	350	416	92	39.5	308	340	A, B	547	117	164	533	363	230	LTKD-01 0.2kW /DGH-3	171
								C	592	140	198	593	373	230	LTKD-02 0.4kW /DGH-4	221
400	16	400	475	102	39	348	372	A	547	117	164	533	363	230	LTKD-01 0.2kW /DGH-3	197
								B	592	140	198	593	373	230	LTKD-02 0.4kW /DGH-4	247
								C	592	140	198	593	400	230	LTKD-02 0.75kW /DGH-4	258
450	18	450	534	114	43	366	406	A	642	140	198	593	373	230	LTKD-02 0.4kW /DGH-4	308
								B, C	642	140	198	593	400	230	LTKD-02 0.75kW /DGH-4	319
500	20	500	589	127	50	405	442	A	642	140	198	593	373	230	LTKD-02 0.4kW /DGH-4	350
								B, C	642	140	198	593	400	230	LTKD-02 0.75kW /DGH-4	357
600	24	600	693	154	64	461	493	A	642	140	198	593	400	230	LTKD-02 0.75kW /DGH-4	460
								B, C	749	210	300	748	477	360	LTKD-05 1.5kW /DGH-5	605

304A-4L

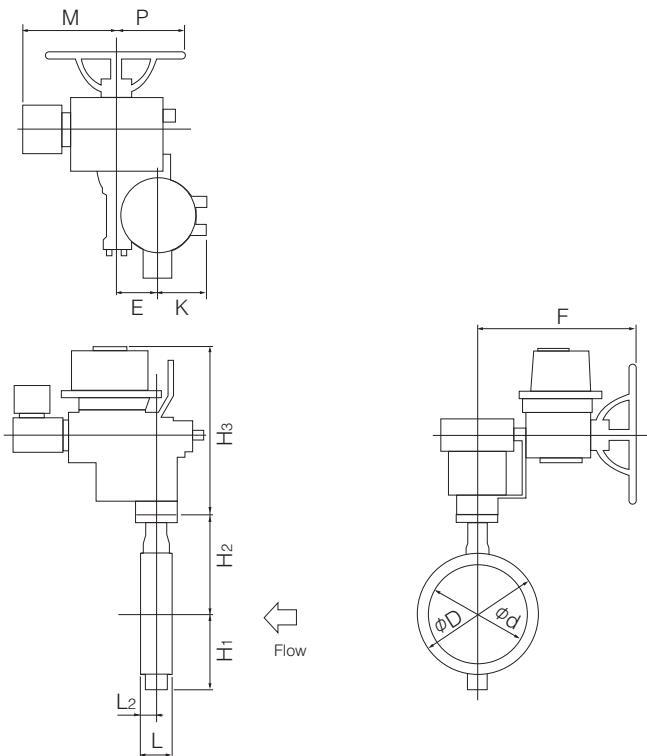

4L Installation direction

<p>Retainer side</p> <p>Flow</p> <p>Stem side</p> <p>4 L A</p>	<p>Retainer side</p> <p>Flow</p> <p>Stem side</p> <p>4 L B</p>	<p>Retainer side</p> <p>Flow</p> <p>Stem side</p> <p>4 L C</p>	<p>Retainer side</p> <p>Flow</p> <p>Stem side</p> <p>4 L D</p>
--	--	--	--

304A Cv value

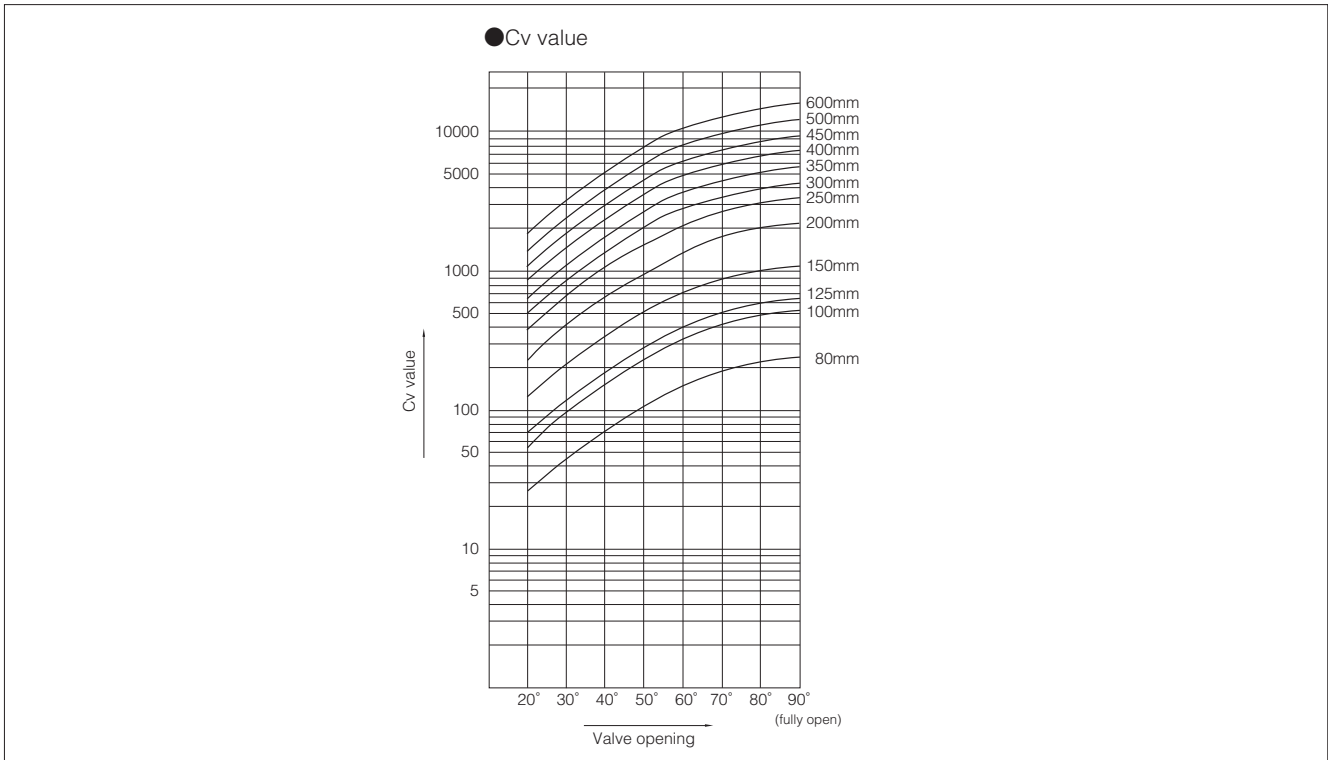

304A Cv value

Nominal size		Valve opening							
mm	inch	20°	30°	40°	50°	60°	70°	80°	90°
80	3	29	52	85	122	162	207	243	252
100	4	49	88	144	207	279	351	414	432
125	5	77	140	230	333	441	549	648	684
150	6	126	225	369	531	720	900	1080	1116
200	8	234	423	693	990	1350	1710	1980	2070
250	10	390	703	1148	1648	2240	2857	3300	3443
300	12	492	888	1454	2081	2838	3612	4172	4354
350	14	648	1170	1915	2741	3739	4758	5496	5736
400	16	829	1496	2449	3505	4780	6084	7027	7334
450	18	1041	1879	3076	4403	6004	7642	8827	9212
500	20	1323	2387	3909	5595	7630	9710	11216	11705
600	24	1929	3481	5700	8159	11126	14161	16356	17070

- Butterfly Valve
- TRITEC**
- TT2**
- 334A**
- 344Q**
- 302A/303Q**
- 304A/304Q**
- 304YA**
- 302Y/304Y**
- 304M (HLV)**
- 507V/508V**
- DTM**
- 846T/847T/847Q**
- 841T/842T**
- 700Z**
- 700G/704G/705G**
- 72WG/72SG/72LG**
- 731P/732P/732Q/752W**
- 731R**
- 700E/700K/700S**
- 704G/722F/720F**
- 227P**
- 907T/908H (MKT)**
- 903L/901C/905C (Bata-check)**

304A pressure loss coefficient

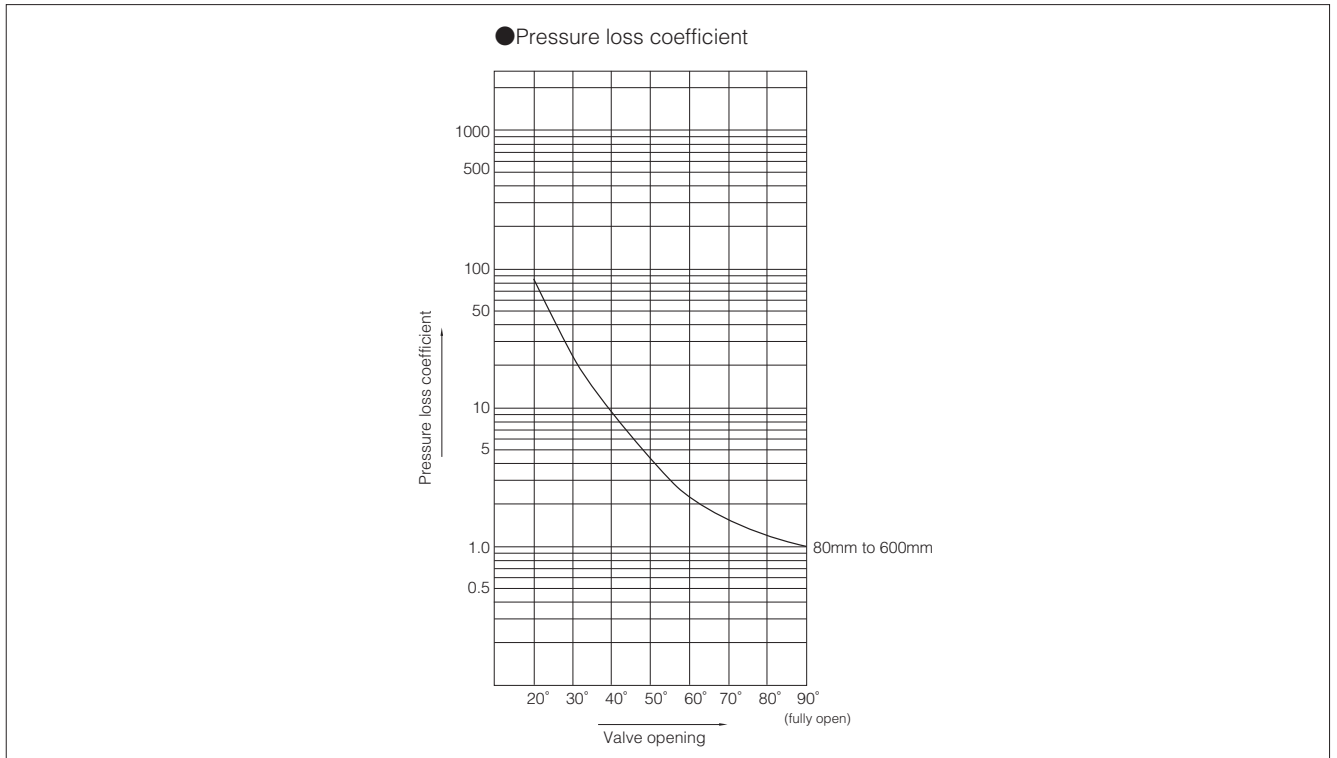

304A Pressure loss coefficient

Nominal size		Valve opening							
mm	inch	20°	30°	40°	50°	60°	70°	80°	90°
80	3	95	29	11	5	3	2	1	1
100	4	98	30	11	5	3	2	1	1
125	5	93	28	10	5	3	2	1	1
150	6	70	22	8	4	2	1	1	1
200	8	62	19	7	3	2	1	1	1
250	10	54	17	6	3	2	1	1	1
300	12	70	21	8	4	2	1	1	1
350	14	68	21	8	4	2	1	1	1
400	16	73	22	8	4	2	1	1	1
450	18	75	23	9	4	2	1	1	1
500	20	72	22	8	4	2	1	1	1
600	24	70	22	8	4	2	1	1	1

304A Flange accommodation

Nominal size		JIS				ASME/API/JPI Class 150	BS4504		DIN		BS10 Table E
mm	inch	5K	10K	16K	20K		PN10	PN16	NP10	NP16	
80	3	×	D	D	D	○	D	D	D	D	×
100	4	×	D	D	D	D	D	D	D	D	×
125	5	×	D	D	D	D	D	D	D	D	×
150	6	×	D	D	D	D	D	D	D	D	×
200	8	×	D	D	D	D	D	D	D	D	×
250	10	×	D	D	D	D	D	D	D	D	×
300	12	×	D	D	D	D	D	D	D	D	×
350	14	D	D	D	D	D	D	D	D	D	D
400	16	D	D	D	D	D	D	D	D	D	D
450	18	D	T	T	T	D	T	T	T	T	D
500	20	T	T	T	T	T	T	T	T	T	T
600	24	T	T	T	T	T	T	T	T	T	T

- : Can be used without flange drilling.
- D : With flange drilling
- T : With flange tapping
- ×

× : Not applicable

Butterfly Valve
TRITEC
TT2
334A
344Q
302A/303Q
304A/304Q
304YA
302Y/304Y
304M (HLV)
507V/508V
DTM
846T/847T/847Q
841T/842T
700Z
700G/704G/705G
72WG/72SG/72LG
731P/732P/732Q/752W
731R
700E/700K/700S
704G/722F/720F
227P
907T/908H (MKT)
903L/901C/905C (Bata-check)

Tom Disco 304A (Wafer)/304Q (Lugged)

304A Applicable pipe list in case of **A**

Nominal size		SGP		Sch20		Sch40		Sch60		Sch80		Sch10S		Sch20S		Minimum internal diameters of piping (mm)
		Retainer (up stream)	Stem Side (down stream)	Retainer (up stream)	Stem Side (down stream)	Retainer (up stream)	Stem Side (down stream)	Retainer (up stream)	Stem Side (down stream)	Retainer (up stream)	Stem Side (down stream)	Retainer (up stream)	Stem Side (down stream)	Retainer (up stream)	Stem Side (down stream)	
mm	inch															
80	3	○	○	○	○	○	○	○	○	○	○	○	○	○	○	72.5
100	4	○	○	○	○	○	○	○	○	○	○	○	○	○	○	93.8
125	5	○	○	○	○	○	○	○	○	○	○	○	○	○	○	119.4
150	6	○	○	○	○	○	○	○	○	×	○	×	○	○	○	147.5
200	8	○	○	○	○	○	○	○	○	×	○	×	○	○	○	197.5
250	10	○	○	○	○	○	○	○	○	×	○	×	○	○	○	248.1
300	12	○	○	○	○	○	○	○	○	×	×	×	○	○	○	297.6
350	14	○	○	○	○	○	○	○	○	×	×	×	—	—	—	330
400	16	○	○	○	○	○	○	○	○	×	○	×	—	—	—	377
450	18	○	○	○	○	○	○	○	○	×	○	×	—	—	—	424
500	20	○	○	○	○	○	○	○	○	×	○	×	—	—	—	470
600	24	—	—	○	○	○	○	○	○	×	×	×	—	—	—	564

304A Applicable pipe list in case of **B**

Nominal size		SGP		Sch20		Sch40		Sch60		Sch80		Sch10S		Sch20S		Minimum internal diameters of piping (mm)
		Retainer (up stream)	Stem Side (down stream)	Retainer (up stream)	Stem Side (down stream)	Retainer (up stream)	Stem Side (down stream)	Retainer (up stream)	Stem Side (down stream)	Retainer (up stream)	Stem Side (down stream)	Retainer (up stream)	Stem Side (down stream)	Retainer (up stream)	Stem Side (down stream)	
mm	inch															
80	3	○	○	○	○	○	○	○	○	○	○	○	○	○	○	63.6
100	4	○	○	○	○	○	○	○	○	○	○	○	○	○	○	87.0
125	5	○	○	○	○	○	○	○	○	○	○	○	○	○	○	112.8
150	6	○	○	○	○	○	○	○	○	○	○	○	○	○	○	142.5
200	8	○	○	○	○	○	○	○	○	×	○	×	○	○	○	193.3
250	10	○	○	○	○	○	○	○	○	×	○	×	○	○	○	248.1
300	12	○	○	○	○	○	○	○	○	×	○	×	○	○	○	297.6
350	14	○	○	○	○	○	○	○	○	○	×	—	—	—	—	323.0
400	16	○	○	○	○	○	○	○	○	○	×	—	—	—	—	371.0
450	18	○	○	○	○	○	○	○	○	○	×	—	—	—	—	418.0
500	20	○	○	○	○	○	○	○	○	○	×	—	—	—	—	464.0
600	24	—	—	○	○	○	○	○	○	○	×	—	—	—	—	557.0

Remark 1: ○=Applicable X=Not applicable

Remark 2: The clearance of disc and pipe is based on API 609 and MSS SP67 80mm to 150mm: 1.5mm, 200mm to 500mm: 3.0mm, 600mm: 6.4mm

Remark 3: In case of "X" shown above, internal pipe diameter or flange is smaller than minimum internal diameter. Consider to put a spacer between a valve and a flange. Consult us.

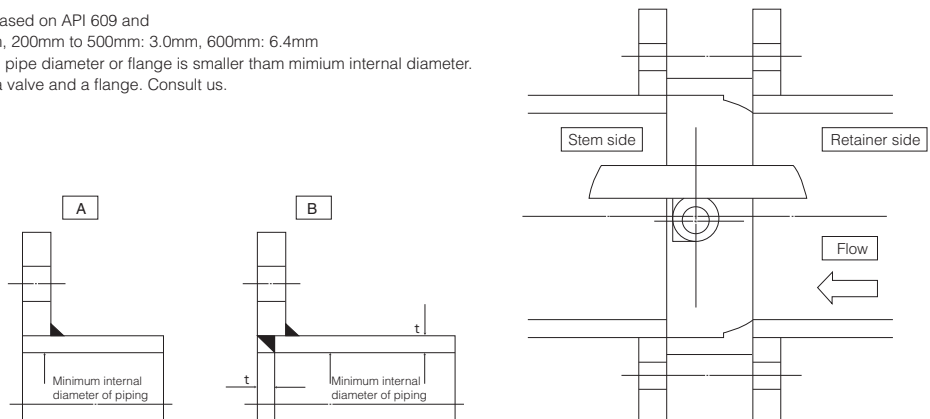

304A Piping gasket

- In case of sheet gasket Any standard can be used.
- In case of spiral gasket
 For ASME / API / JPI flange Any standard gaskets with inner/outer ring can be used.
 For JIS flange Use special spiral gasket shown below.

Special spiral gasket for JIS flange size

Nominal size		JIS flange					
		5K, 10K, 16K, 20K			5K	10K	16K, 20K
mm	inch	D1	D2	D3	D4	D4	D4
80	3	89	97	120	×	134	140
100	4	115	124	146	×	159	165
125	5	140	151	177	×	190	202
150	6	166	178	207	×	220	237
200	8	217	227	257	×	270	282
250	10	268	282	318	×	332	354
300	12	319	331	362	×	377	404
350	14	356	369	399	412	422	450
400	16	406	420	457	472	484	508
450	18	458	472	517	532	539	573
500	20	508	532	567	582	594	628
600	24	610	626	672	689	700	734

Remark1; X: Not applicable

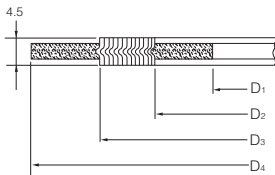

Applicable standard for spiral gasket

Nominal size		Tomoe special			Standard gasket		
		JIS 10K	JIS 16K JIS 20K	ASME Class 125/150	JIS 10K	JIS 16K JIS 20K	ASME Class 125/150
mm	inch						
80	3	○	○	○	×	×	○
100	4	○	○	○	×	×	○
125	5	○	○	○	×	×	○
150	6	○	○	○	×	×	○
200	8	○	○	○	×	×	○
250	10	○	○	○	×	×	○
300	12	○	○	○	×	×	○
350	14	○	○	○	×	×	○
400	16	○	○	○	×	×	○
450	18	○	○	○	×	×	○
500	20	○	○	○	×	×	○
600	24	○	○	○	×	×	○

Remark 1: ○: Applicable, X: Not applicable

Remark 2: In case a minute leakage of gas (less than 100PPm) becomes a problem, please inquire of our business charge.

304A Applicable standard for standard piping gasket

Nominal size		Max. allowable inside diameter (D)	Joint sheet or RPTFE solid gasket (t≤2mm)					PTFE mold type gasket VALQUA or NICHIAS				
			JIS 5K	JIS 10K	JIS 16K JIS 20K	ASME Class 125/150	JPI 150Lb	JIS 5K	JIS 10K	JIS 16K JIS 20K	ASME Class 125/150	JPI 150Lb
mm	inch											
80	3	97	×	○	○	○	○	×	○	○	○	○
100	4	124	×	○	○	○	○	×	○	○	○	○
125	5	151	×	○	○	○	○	×	○	○	○	○
150	6	178	×	○	○	○	○	×	○	○	○	○
200	8	227	×	○	○	○	○	×	○	○	○	○
250	10	282	×	○	○	○	○	×	○	○	○	○
300	12	331	×	○	○	○	○	×	○	○	○	○
350	14	362	○	○	○	○	○	○	○	○	○	○
400	16	414	○	○	○	○	○	○	○	○	○	○
450	18	468	○	○	○	○	○	○	○	○	○	○
500	20	518	○	○	○	○	○	○	○	○	○	○
600	24	619	○	○	○	○	○	○	○	○	○	○

Remark; ○: Applicable, X: Not applicable

※ All standard joint seats and PTFE cut gaskets can be used.

※ Only VALQUA flawless gaskets (Part No.: 7030/7031/7035) and NICHIAS PTFE cushion gaskets (Part No.: 9010/9011) can be used. (Products from other manufacturers cannot be used due to their dimensions.)

Butterfly Valve
TRITEC
TT2
334A
344Q
302A/303Q
304A/304Q
304YA
302Y/304Y
304M (HLV)
507V/508V
DTM
846T/847T/847Q
841T/842T
700Z
700G/704G/705G
72WG/72SG/72LG
731P/732P/732Q/752W
731R
700E/700K/700S
704G/722F/720F
227P
907T/908H (MKT)
903L/901C/905C (Bata-check)

Tom Disco 304A (Wafer) / 304Q (Lugged)

304A Piping Bolts and Nuts Sizes

Nominal size		JIS5K		JIS10K		JIS16K	
mm	inch	Long Bolts and Nuts	Setting Bolts	Long Bolts and Nuts	Setting Bolts	Long Bolts and Nuts	Setting Bolts
80	3	—	—	8-M16×145	—	8-M20×170	—
100	4	—	—	8-M16×145	—	8-M20×170	—
125	5	—	—	8-M20×170	—	8-M22×190	—
150	6	—	—	8-M20×170	—	12-M22×190	—
200	8	—	—	12-M20×170	—	12-M22×190	—
250	10	—	—	12-M22×190	—	12-M24×210	—
300	12	—	—	16-M22×190	—	16-M24×225	—
350	14	12-M22×210	—	16-M22×210	—	16-M30(P3)×245	—
400	16	16-M22×220	—	16-M24×235	—	16-M30(P3)×265	—
450	18	16-M22×230	※ 1	16-M24×250	4-M24×84×60	16-M30(P3)×280	4-M30(P3)× 95×65
					4-M24×58×50		4-M30(P3)× 73×50
500	20	16-M22×245	4-M22×80×50	16-M24×260	4-M24×90×60	16-M30(P3)×300	4-M30(P3)×105×65
			4-M22×60×50		4-M24×70×60		4-M30(P3)× 81×50
600	24	16-M24×280	4-M24×84×60	20-M30(P3)×300	4-M30(P3)×81×50	20-M36(P3)×345	4-M36(P3)×100×60
			4-M24×65×50		4-M30(P3)×65×50		4-M36(P3)× 82×50

Nominal size		JIS20K		ASME / API / JPI Class 150	
mm	inch	Long Bolts and Nuts	Setting Bolts	Long Bolts and Nuts	Setting Bolts
80	3	8-M20×170	—	4-U5/8-11UNC×155	—
100	4	8-M20×170	—	8-U5/8-11UNC×155	—
125	5	8-M22×190	—	8-U3/4-10UNC×175	—
150	6	12-M22×190	—	8-U3/4-10UNC×175	—
200	8	12-M22×190	—	8-U3/4-10UNC×205	—
250	10	12-M24×210	—	12-U7/8- 9UNC×215	—
300	12	16-M24×225	—	12-U7/8- 9UNC×215	—
350	14	16-M30(P3)×260	—	12-U1 - 8UNC×240	—
400	16	16-M30(P3)×280	—	16-U1 - 8UNC×255	—
450	18	16-M30(P3)×300	4-M30(P3)×105×65	16-U1 1/8- 8UN×280	—
			4-M30(P3)× 81×50		
500	20	16-M30(P3)×315	4-M30(P3)×110×60	16-U1 1/8- 8UN×295	4-U1 1/8- 8UN×105×50
			4-M30(P3)× 90×65		4-U1 1/8- 8UN× 80×50
600	24	20-M36(P3)×360	4-M36(P3)×108×60	16-U1 1/4- 8UN×340	4-U1 1/4- 8UN×100×50
			4-M36(P3)× 90×50		4-U1 1/4- 8UN× 90×50

※ 1 Tapped drilling is also applicable.

Remark: Use SNB 7/S45C (A193 B7/A, 194 2H) SUS304/SUS304

For long bolt, use full thread bolt.

For hexagon nut, use heavy nut.

A metric screw should have 3 pitches if its nominal diameter exceeds M30.

A unified screw should have 8 threads per inch if its nominal diameter exceeds 1 inch.

Hexagon bolts (set bolts) are indicated with the retainer side on the up side and the stem side on down side.

Examples

Long bolts: 12 - M22 × 185
 N M L

Setting bolts: 4 - M30 × 95 × 65
 (Hexagon bolts) N M L S

Long bolts and nuts (full thread)

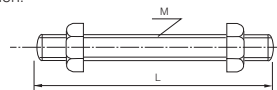

Setting bolts (Hexagon bolts)

