

302Y Wafer

304Y Wafer

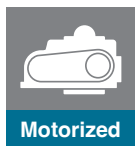
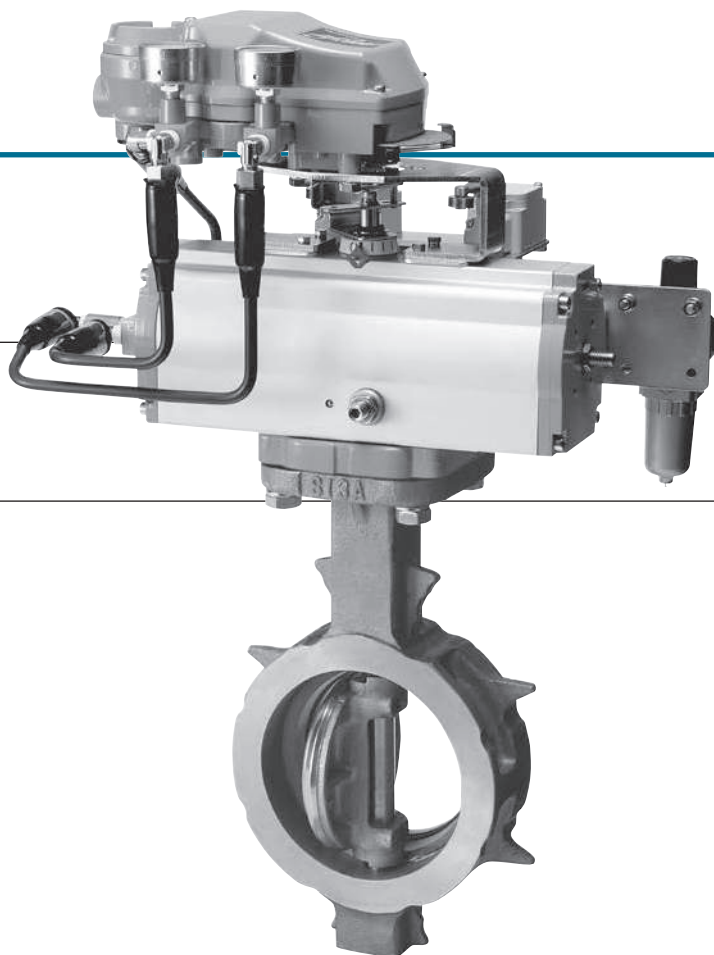

Features and Benefits

Ideal shut-off with new stopper mechanism. Two types of seat – metal and PTFE – for optimum performance in your application.

Unique stopper structure

For the 40 to 300mm models, automatic aligning and disc overrun prevention are ensured by the special spherical design of the inner surface of the body disc hub edge. Disc overrun is prevented by a protrusion on the inner surface of the body.

Double eccentric structure

The disc is rotated easily by minimal torque and unseats after turning only a small angle. Moreover, seat abrasion is prevented for a long life of reliable sealing.

Thin disc with a rigid construction

The disc is thin but ribbed for extra rigidity. The disc reduces thermal expansion and provides consistent sealing even in changing temperature or pressure situations.

Seal the flow from both directions

Seals flow in both directions. Valve can be used as is, even if the flow changes direction. (There are pressure limitations for each direction of flow. See Pressure-temperature leakage chart for recommended specifications.)

Easy replacement of the seat ring

The ball lock method is used to simplify replacement of the seat ring.

302Y Resilient metal seat ring with original coil spring

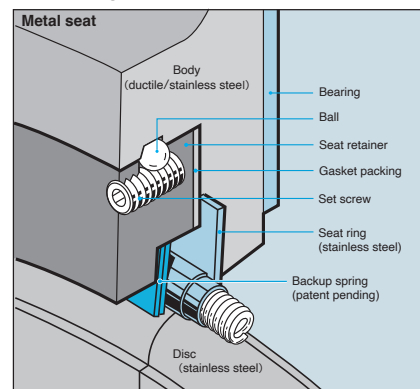

304Y PTFE seat ring is inert to most chemical products and solvents

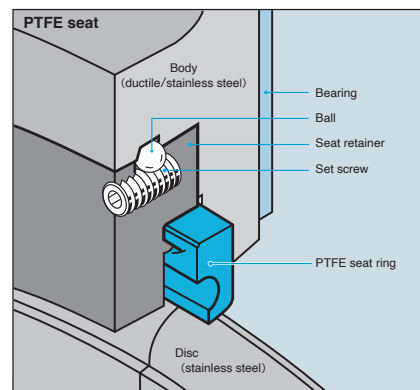

General Description

The 300 series is optimal for applications that cannot be handled by valves with rubber seats because of the temperature, pressure, fluid velocity or fluid itself. Two types are available: the 302Y with a metal seat for steam line applications and the 304Y with a PTFE seat for chemical line applications.

Pressure-Temperature Leakage Chart

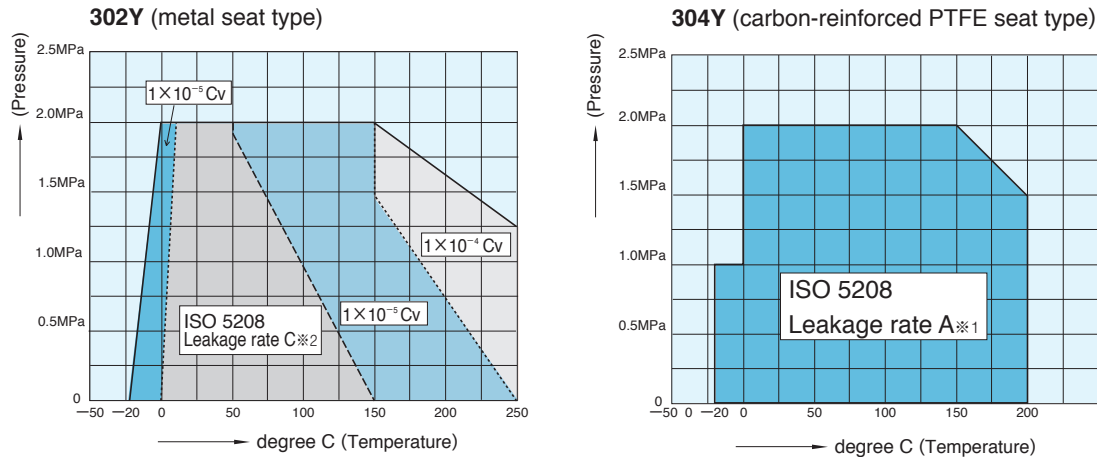

※ The operating range is the area within the thick lines

■ ISO 5208 pressure test (To calculate leak rate, refer to "Formula for leak rate" on Data-05 at the end of the catalog.)

※1 Leakage rate A : 0 leakage(tight shut-off)

※2 Leakage rate C : 0.03mm²/s X nominal size(mm) (fluid)
3Nmm³/s X nominal size(mm) (gas)

Standard Specifications

Valve type	302Y	304Y	
Seat type	Metal seat type	PTFE seat type	
Valve nominal size	40mm to 300mm	40mm to 300mm	
Flange accommodation ※1	JIS 5K/10K/16K/20K, ASME class 150, BS10 Table E, BS4504 PN 6/10/16, DIN PN 6/10/16 etc		
Face-to-face dimensions	JIS B 2002 (46 series) / ISO 5752 (20 series)		
Actuator mounting flange	ISO 5211/1		
Pressure rating	ASME (B16.34, B16.42) Class 150		
Max. working pressure	2.0MPa (250, 300mm: 1.6MPa)	2.0 MPa	
Body shell test	working pressure×1.5(hydraulic) (Max. 3.0MPa)		
Seat leak test	working pressure×1.1(pneumatic) (Max. 2.2MPa)		
Flow direction	Bi -directional (Standard direction of pressurization: Retainer side) On the valve disc side: 2.0MPa On the valve stem side: 1.0MPa The max. pressure on the valve disc side for 250mm and 300mm valves is 1.6MPa	Bi -directional (Standard direction of pressurization: Retainer side) On the valve disc side: 2.0MPa	
Seat leakage	ISO 5208 leakage rate C	ISO 5208 leakage rate A (tight shut-off)	
Working temperature range	-20 to 250 degrees C	-20 to 200 degrees C	
Standard materials	Body ※2	FCD450 (Tuffride treated) OR SCS13A	
	Disc	SCS13A (HdCr plating)	
	Stem ※3	SUS420J2 or SUS329J1	
	Seat ring	SUS316	RPTFE (with carbon graphite) or the optional specification PFA + D.PTFE
	Gland packing	PTFE with carbon graphite	
Bonnet type	Open bonnet		
Actuators	Lock lever	40 to 150mm	
	Worm gear	40 to 300mm	
	Pneumatic cylinder	40 to 300mm	
	Motorised	40 to 300mm	
Coating	Silicon resin coating (Grey N7) for 200 degrees C or lower. Heat resistant silver coating for over 200 degrees C. No painting for stainless steel.		

※1. 65mm is not applicable for BS 10 Table E.

※2. For size 40mm, only SCS13A is available for the body material.

※3. For size 40mm, only SUS329J1 is available for the stem material.

※There is possibility of seat leakage when fluid (powder/liquid) is solidified by working temperature and other cause, especially the valve is in a vertical position(e.g. at the bottom area of discharge spout of hopper and tank). Please consult us.

Butterfly Valve
TRITEC
TT2
334A
344Q
302A/303Q
304A/304Q
304YA
302Y/304Y
304M (HLV)
507V/508V
DTM
846T/847T/847Q
841T/842T
700Z
700G/704G/705G
72WG/72SG/72LG
731P/732P/732Q/752W
731R
700E/700K/700S
704G/722F/720F
227P
907T/908H (MKT)
903L/901C/905C (Beta-check)

Tom Disco 302Y/304Y

302Y/304Y Expanded view of components

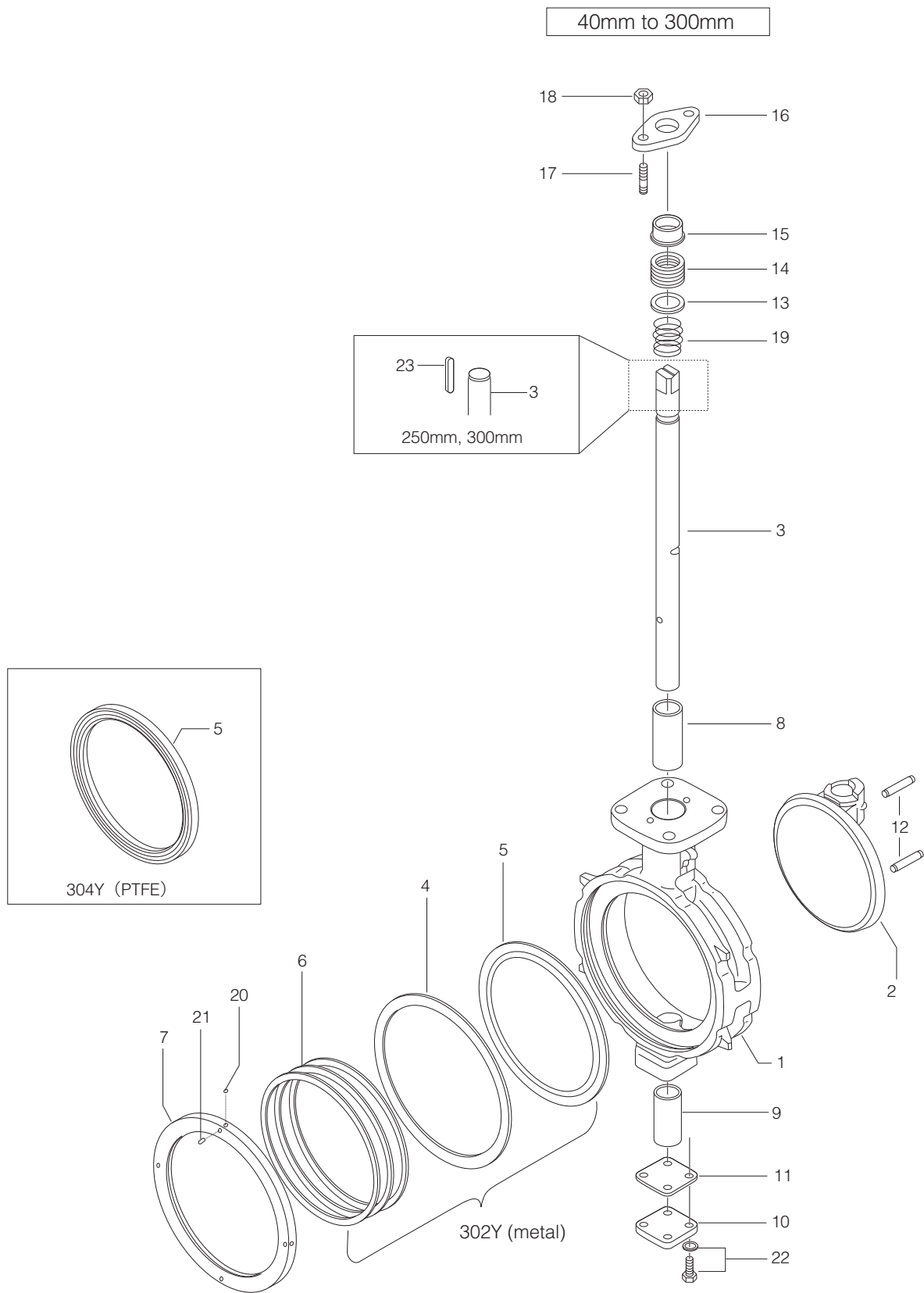

302Y/304Y Parts list

■ 302Y Parts list

No.	Description	Q'ty	Remarks
1	Body	1	
2	Disc	1	
3	Stem	1	
★ 4	Seat ring gasket	1	
★ 5	Seat ring	1	
★ 6	Back-up spring	2	40mm to 100mm
		3	125mm to 200mm
		4	250mm, 300mm
7	Seat ring retainer	1	
8	Top shaft bearing	1	
9	Bottom shaft bearing	1	
10	Bottom cover	1	
★ 11	Bottom gasket	1	
12	Taper pin	2	
13	Packing retainer	1	
★ 14	Gland packing	1 sets	
15	Rough gland	1	
16	Gland flange	1	
17	Gland bolt	2	
18	Gland nut	2	
19	Gland coil	1	Only 40mm to 150mm
★ 20	Ball	2	40mm to 125mm
		4	150mm to 300mm
★ 21	Set screw	2	40mm to 125mm
		4	150mm to 300mm
22	Hexagon bolt, Spring washer	4 sets	
23	Key	1	Only 250mm, 300mm

■ 304Y Parts list

No.	Description	Q'ty	Remarks
1	Body	1	
2	Disc	1	
3	Stem	1	
★ 5	Seat ring	1	
7	Seat ring retainer	1	
8	Top shaft bearing	1	
9	Bottom shaft bearing	1	
10	Bottom cover	1	
★ 11	Bottom gasket	1	
12	Taper pin	2	
13	Packing retainer	1	
★ 14	Gland packing	1 sets	
15	Gland bush	1	
16	Gland flange	1	
17	Gland bolt	2	
18	Gland nut	2	
19	Gland coil	1	Only 40mm to 150mm
★ 20	Ball	2	40mm to 125mm
		4	150mm to 300mm
★ 21	Set screw	2	40mm to 125mm
		4	150mm to 300mm
22	Hexagon bolt, Spring washer	4 sets	
23	Key	1	Only 250mm, 300mm

Remark: The ★ indicates recommended spare parts. They are supplied as "Seat ring set" with a small hexagonal spanner to remove set screws (Part #21 Set screw).

Butterfly Valve
TRITEC
TT2
334A
344Q
302A/303Q
304A/304Q
304YA
302Y/304Y
304M (HLV)
507V/508V
DTM
846T/847T/847Q
841T/842T
700Z
700G/704G/705G
72WG/72SG/72LG
731P/732P/732Q/752W
731R
700E/700K/700S
704G/722F/720F
227P
907T/908H (MKT)
903L/901C/905C (Bata-check)

Tom Disco 302Y/304Y

302Y Actuator selection chart

302Y

Model	Category	Size ($\frac{\text{mm}}{\text{inch}}$)									
		40 1 1/2	50 2	65 2 1/2	80 3	100 4	125 5	150 6	200 8	250 10	300 12
1T	TL	1T-1			1T-2			1T-3			
	TH	1T-1			1T-2			1T-3			
2U,2S	TL	2U-0	2U-1	2U-2	2U-3	2U-4	DGH-2	DGH-3			
	TH	2U-0	2U-1	2U-2	2U-3	2U-4	DGH-2	DGH-3			
7E,3A	TL	T85		T200		T380	T750	TGA-125			
	TH	T85		T200		T380	T750	TGA-125			
7G,7F 3U,3K	TL	T200S	T380S		T750S		TG-12S	TG-14S			
	TH	T200S	T380S		T750S		TG-12S	TG-14S			
4I	TL	4I-0		4I-2		4I-2.5	4I-3	4I-4 (control)			
	TH	4I-0		4I-2		4I-2.5	4I-3	4I-4			
4J,4L	TL	SRJ-010			SRJ-020		SRJ-060	LTKD-01 0.2kW/ DGH-3			
	TH	SRJ-010			SRJ-020		SRJ-060	LTKD-01 0.2kW/ DGH-3			

Remark: For the 300mm model with the accessories below (for control), type 4I-4 should be selected.

- Micom unit
- Servo unit
- Speed control unit
- Potentiometer

302Y Pressure rating

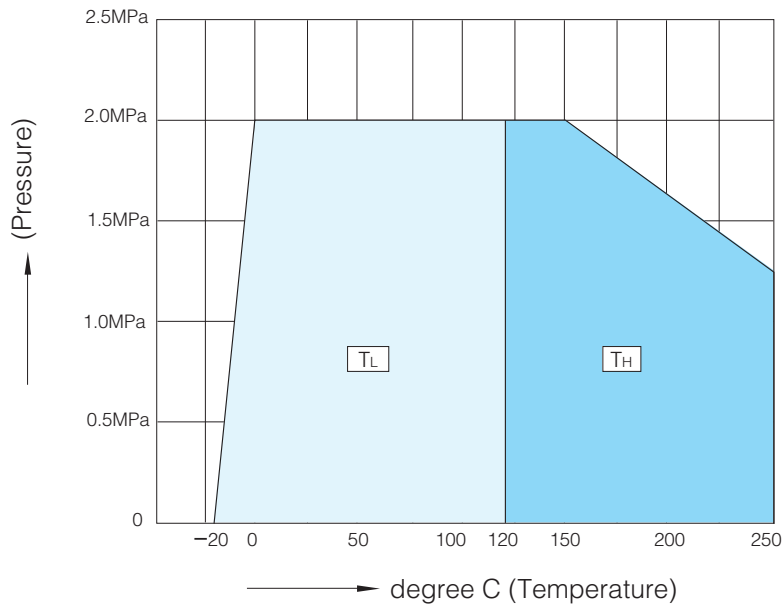

304Y Actuator selection chart

304Y

Model	Category	Size (mm / inch)									
		40	50	65	80	100	125	150	200	250	300
		1 1/2	2	2 1/2	3	4	5	6	8	10	12
1T	T ₁₀	1T-1			1T-2			1T-3			
	T ₂₀	1T-1			1T-2			1T-3			
2U	T ₁₀	2U-0	2U-1	2U-2			2U-4		2U-5		
	T ₂₀	2U-0	2U-1	2U-2			2U-4		2U-5		
7E	T ₁₀	T35		T85		T200		T380		T750	
	T ₂₀	T35		T85		T200		T380		T750	
7G,7F 3U,3K	T ₁₀	T85S		T200S		T380S	T750S		TG-12S		
	T ₂₀	T85S		T200S		T380S	T750S		TG-12S		
4I	T ₁₀	4I-0			4I-1	4I-2		4I-2.5	4I-3		
	T ₂₀	4I-0			4I-1	4I-2		4I-2.5	4I-3		
4J	T ₁₀	SRJ-010				SRJ-020		SRJ-060			
	T ₂₀	SRJ-010				SRJ-020		SRJ-060			

Butterfly Valve
TRITEC
TT2
334A
344Q
302A/303Q
304A/304Q
304YA
302Y/304Y
304M (HLV)
507V/508V
DTM
846T/847T/847Q
841T/842T
700Z
700G/704G/705G
72WG/72SG/72LG
731P/732P/732Q/752W
731R
700E/700K/700S
704G/722F/720F
227P
907T/908H (MKT)
903L/901C/905C (Bata-check)

304Y Pressure rating

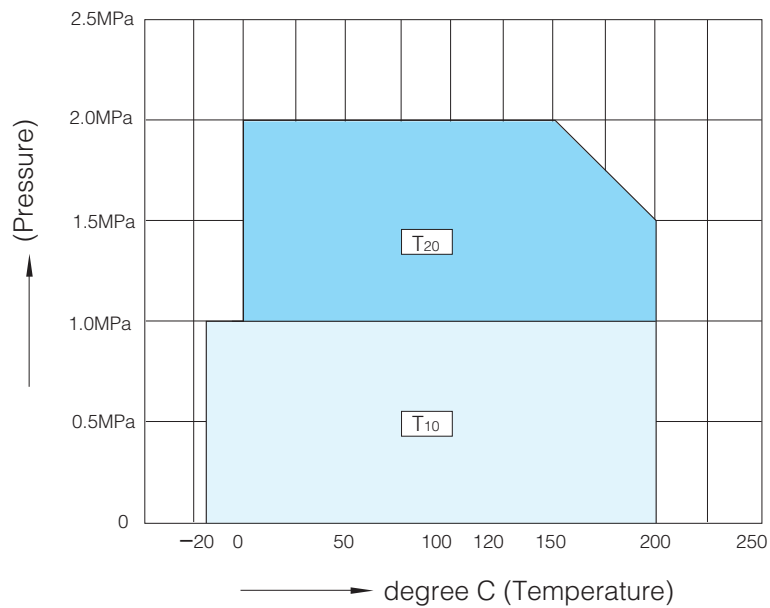

Tom Disco 302Y/304Y

302Y/304Y Bare shaft (01: 40mm to 200mm, 02: 250mm, 300mm)

302Y-01/02, 304Y-01/02

Stem design	Nominal size		Dimension (mm)														Approx. Mass (kg)
	mm	inch	ϕd	ϕD	L	L ₂	H ₁	H ₂	a ₁	a ₂	$\square S_1$	ϕd_2	b	t ₂	t	Flange type	
01	40	1 1/2	48	81	33	15	64	118	47.5	11.5	8	10	—	—	12	F07	2.1
	50	2	60	97	43	21	74	125	47.5	11.5	10	12	—	—	12	F07	2.5
	65	2 1/2	74	117	46	22	85	138	47.5	11.5	12	14	—	—	12	F07	3.6
	80	3	89	127	46	21	95	147	52.5	16.5	14	16	—	—	15	F10	4.7
	100	4	112	152	52	22	110	170	52.5	16.5	14	16	—	—	15	F10	5.7
	125	5	137	183	56	24	139	185	52.5	16.5	16	20	—	—	15	F10	8.8
	150	6	163	213	57	23	164	205	55.5	20	18	22	—	—	15	F12	12
02	200	8	213	263	62	26	190	235	63.0	30	24	28	—	—	15	F12	18
	250	10	263	325	70	30	236	283	108.0	65	—	32	10	3	18	F14	32
	300	12	315	368	80	34	246	310	113.0	70	—	35	10	3	18	F14	39

Stem design	01 : Square
	02 : Round with key

Top flange

Flange type	$\square S$	ϕC_1	N	B.H.
F07	70	70	4	9
F10	102	102	4	11
F12	125	125	4	13
F14	140	140	4	19

302Y/304Y 40mm to 200mm

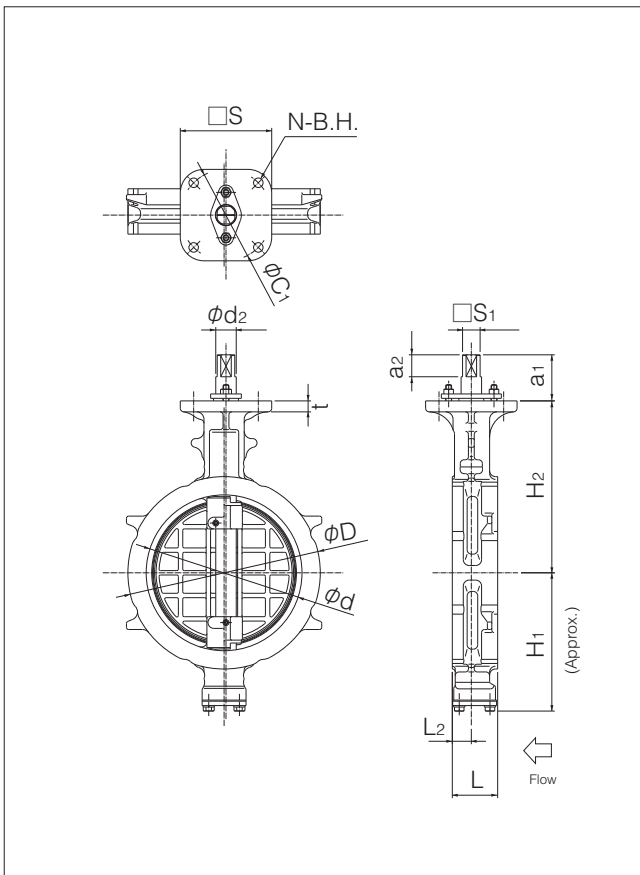

302Y/304Y 250mm, 300mm

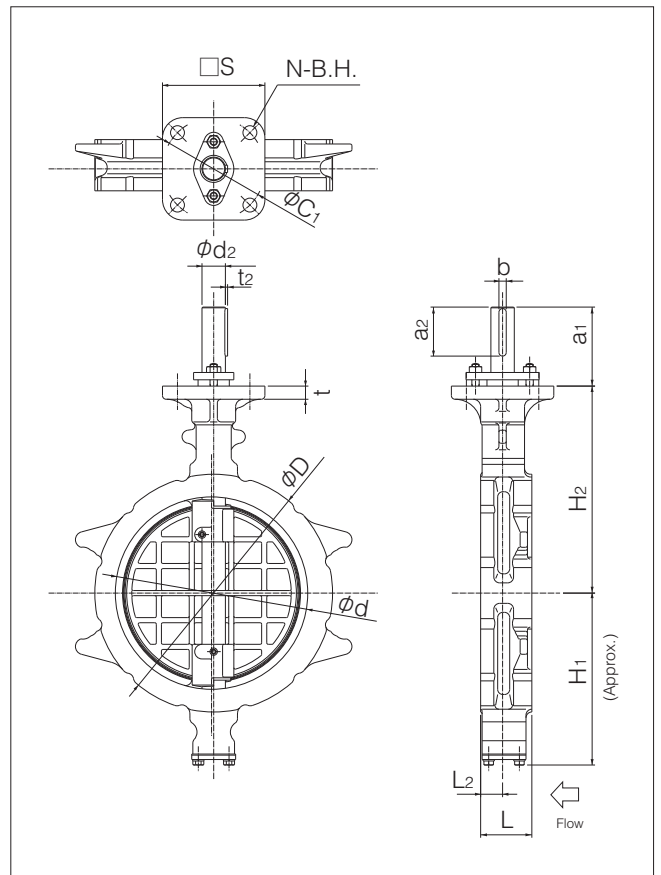

Lock lever type 302Y/304Y-1T (40mm to 150mm)

■ 302Y-1T, 304Y-1T

Nominal size		Dimension (mm)								Lever type	Approx. Mass (kg)
mm	inch	ϕd	ϕD	L	L ₂	H ₁	H ₂	H ₃	W		
40	1 1/2	48	81	33	15	64	118	91	200	1T-1	3.1
50	2	60	97	43	21	74	125	91	200	1T-1	3.5
65	2 1/2	74	117	46	22	85	138	91	200	1T-1	4.6
80	3	89	127	46	21	95	147	117	300	1T-2	6.9
100	4	112	152	52	22	110	170	117	300	1T-2	7.8
125	5	137	183	56	24	139	185	117	300	1T-2	10.9
150	6	163	213	57	23	164	205	125	350	1T-3	14.1

■ 302Y-1T, 304Y-1T

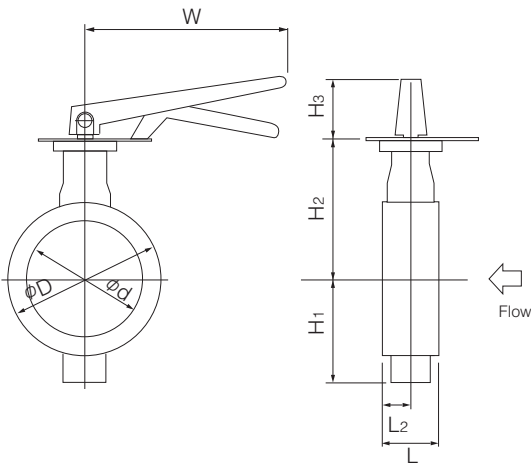

■ 1T Installation direction

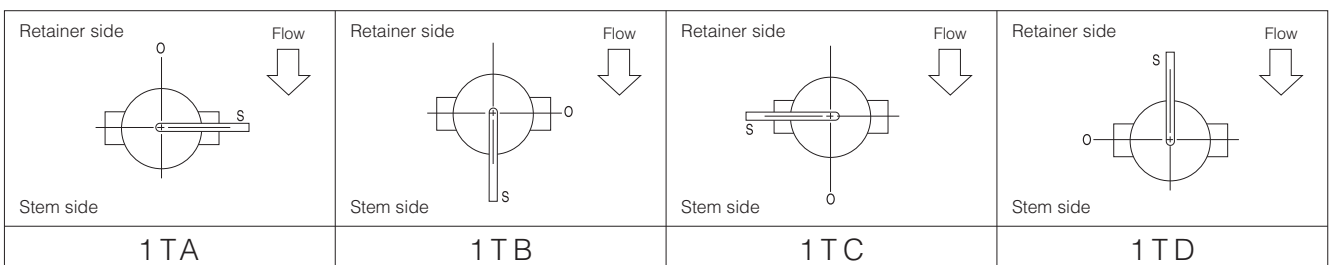

Butterfly Valve

TRITEC

TT2

334A

344Q

302A/303Q

304A/304Q

304YA

302Y/304Y

304M (HLV)

507V/508V

DTM

846T/847T/847Q

841T/842T

700Z

700G/704G/705G

72WG/72SG/72LG

731P/732P/732Q/752W

731R

700E/700K/700S

704G/722F/720F

227P

907T/908H (MKT)

903L/901C/905C (Bata-check)

Tom Disco 302Y/304Y

Worm gear type 302Y-2U (40mm to 150mm) / 302Y-2S (200mm to 300mm) / 304Y-2U (40mm to 300mm)

302Y-2U (40mm to 150mm) / 2S (200mm to 300mm)

Nominal size		Dimension (mm)											Gear type	Approx. Mass (kg)
mm	inch	ϕd	ϕD	L	L ₂	H ₁	H ₂	H ₃	E	K	F	ϕW		
40	1 1/2	48	81	33	15	64	118	56	36	46	160	100	2U-0	5
50	2	60	97	43	21	74	125	56	36	46	160	100	2U-1	5.4
65	2 1/2	74	117	46	22	85	138	56	36	46	160	100	2U-1	6.5
80	3	89	127	46	21	95	147	61	44	53	173.5	160	2U-2	7.6
100	4	112	152	52	22	110	170	61	44	53	173.5	160	2U-2	8.6
125	5	137	183	56	24	139	185	61	44	53	173.5	160	2U-3	11.9
150	6	163	213	57	23	164	205	77.5	87.5	90	222.5	200	2U-4	28.5
200	8	213	263	62	26	190	235	72	85	126	246	280	DGH-2	38
250	10	263	325	70	30	236	283	97	117	164	335	355	DGH-3	69
300	12	315	368	80	34	246	310	97	117	164	335	355	DGH-3	76

304Y-2U

Nominal size		Dimension (mm)											Gear type	Approx. Mass (kg)
mm	inch	ϕd	ϕD	L	L ₂	H ₁	H ₂	H ₃	E	K	F	ϕW		
40	1 1/2	48	81	33	15	64	118	56	36	46	160	100	2U-0	5
50	2	60	97	43	21	74	125	56	36	46	160	100	2U-1	5.4
65	2 1/2	74	117	46	22	85	138	56	36	46	160	100	2U-1	6.5
80	3	89	127	46	21	95	147	61	44	53	173.5	160	2U-2	7.6
100	4	112	152	52	22	110	170	61	44	53	173.5	160	2U-2	8.6
125	5	137	183	56	24	139	185	61	44	53	173.5	160	2U-2	11.9
150	6	163	213	57	23	164	205	77.5	87.5	90	222.5	200	2U-4	28.5
200	8	213	263	62	26	190	235	77.5	87.5	90	222.5	200	2U-4	34.5
250	10	263	325	70	30	236	283	90	87.5	90	222.5	280	2U-4	49.7
300	12	315	368	80	34	246	310	92	90	105	266	280	2U-5	61

302Y-2U/2S

304Y-2U

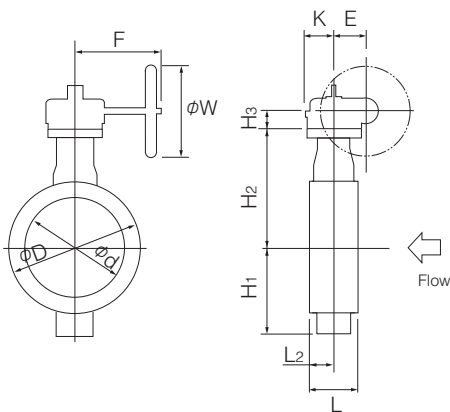

2U/2S Installation direction

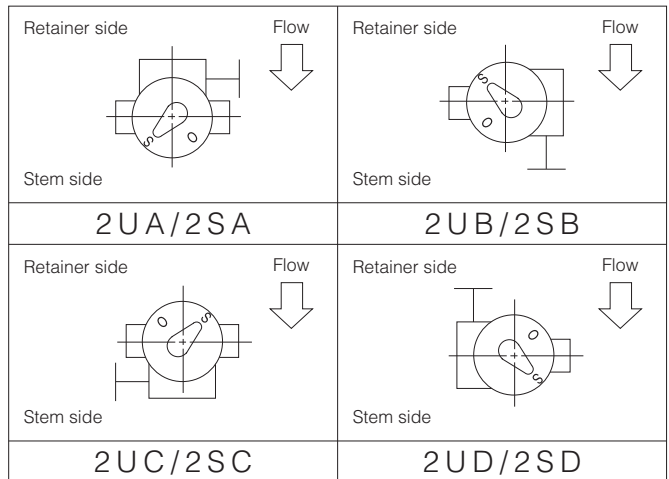

Double-acting pneumatic cylinder type 302Y-7E (40mm to 200mm) / 304Y-7E (40mm to 300mm)

■ 302Y-7E

Nominal size		Dimension (mm)													Cylinder type	Approx. Mass (kg)
mm	inch	ϕd	ϕD	L	L ₂	H ₁	H ₂	Category	H ₃	H ₄	A	P	f ₁	f ₂		
40	1 1/2	48	81	33	15	64	118	T _{L,TH}	168	26.5	276	142	75	47	T85	8
50	2	60	97	43	21	74	125	T _{L,TH}	168	26.5	276	142	75	47	T85	8
65	2 1/2	74	117	46	22	85	138	T _L	168	26.5	276	142	75	47	T85	9
								T _H	203	26.5	346	176	79	57	T200	13
80	3	89	127	46	21	95	147	T _L	168	26.5	276	142	75	47	T85	11
								T _H	203	26.5	346	176	79	57	T200	14
100	4	112	152	52	22	110	170	T _L	203	26.5	346	176	79	57	T200	15
								T _H	231	26.5	423	214	91	69	T380	21
125	5	137	183	56	24	139	185	T _L	203	26.5	346	176	79	57	T200	18
								T _H	231	26.5	423	214	91	69	T380	24
150	6	163	213	57	23	164	205	T _L	231	29.5	423	214	91	69	T380	28
								T _H	269	29.5	546	270	118	85	T750	38
200	8	213	263	62	26	190	235	T _{L,TH}	269	29.5	546	270	118	85	T750	44

■ 304Y-7E

Nominal size		Dimension (mm)													Cylinder type	Approx. Mass (kg)
mm	inch	ϕd	ϕD	L	L ₂	H ₁	H ₂	Category	H ₃	H ₄	A	P	f ₁	f ₂		
40	1 1/2	48	81	33	15	64	118	T _{10,T20}	125	26.5	228	116	57	29	T35	5
50	2	60	97	43	21	74	125	T _{10,T20}	125	26.5	228	116	57	29	T35	5
65	2 1/2	74	117	46	22	85	138	T ₁₀	125	26.5	228	116	57	29	T35	6
								T ₂₀	168	26.5	276	142	75	47	T85	9
80	3	89	127	46	21	95	147	T _{10,T20}	168	26.5	276	142	75	47	T85	11
100	4	112	152	52	22	110	170	T ₁₀	168	26.5	276	142	75	47	T85	12
								T ₂₀	203	26.5	346	176	79	57	T200	15
125	5	137	183	56	24	139	185	T _{10,T20}	203	26.5	346	176	79	57	T200	18
150	6	163	213	57	23	164	205	T _{10,T20}	203	29.5	346	176	79	57	T200	22
200	8	213	263	62	26	190	235	T _{10,T20}	231	29.5	423	214	91	69	T380	34
250	10	263	325	70	30	236	283	T ₁₀	231	190	423	214	91	87.5	T380	62
								T ₂₀	269	190	546	270	118	87.5	T750	72
300	12	315	368	80	34	246	310	T _{10,T20}	269	190	546	270	118	87.5	T750	79

■ 302Y/304Y-7E

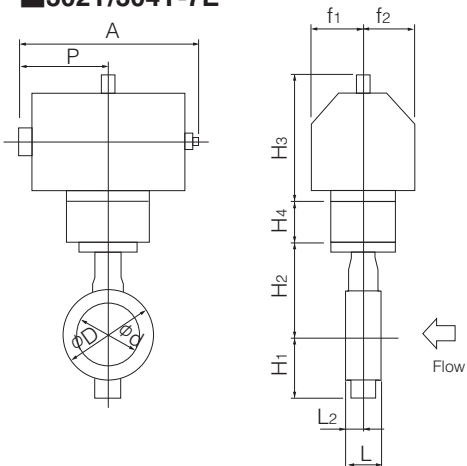

■ 7E Installation direction

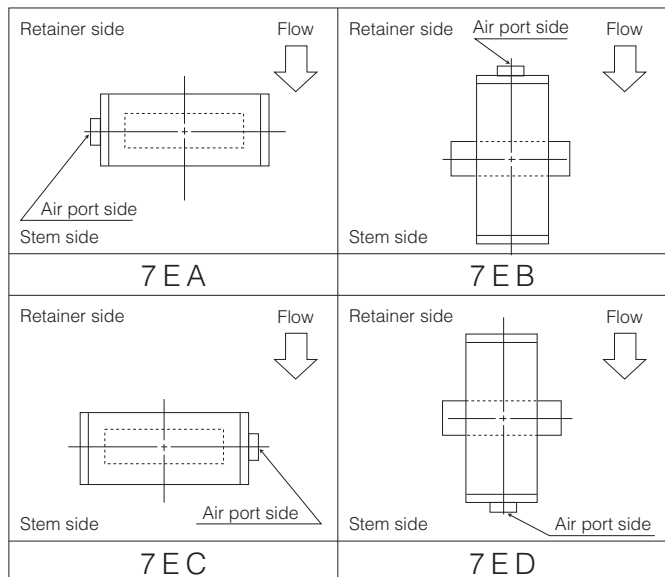

Butterfly Valve
TRITEC
TT2
334A
344Q
302A/303Q
304A/304Q
304YA
302Y/304Y
304M (HLV)
507V/508V
DTM
846T/847T/847Q
841T/842T
700Z
700G/704G/705G
72WG/72SG/72LG
731P/732P/732Q/752W
731R
700E/700K/700S
704G/722F/720F
227P
907T/908H (MKT)
903L/901C/905C (Bata-check)

Tom Disco 302Y/304Y

Double-acting pneumatic cylinder type 302Y-3A (250, 300mm)

302Y-3A

Nominal size		Dimension (mm)												Cylinder type	Approx. Mass (kg)
mm	inch	ϕd	ϕD	L	L ₂	H ₁	H ₂	Category	H ₃	A	P	f ₁	f ₂		
250	10	263	325	70	30	236	283	T _L ,T _H	424	754	381	71	167	TGA-125	78
300	12	315	368	80	34	246	310	T _L ,T _H	424	754	381	71	167	TGA-125	85

302Y-3A

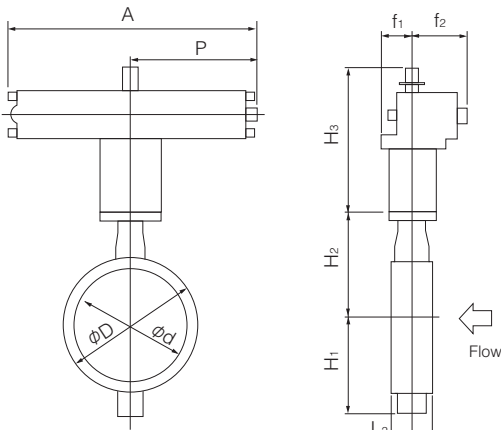

3A Installation direction

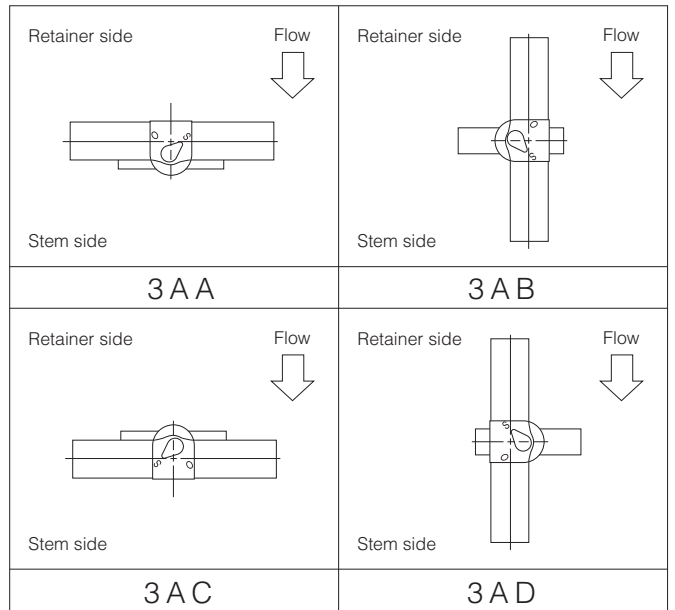

304A-7F

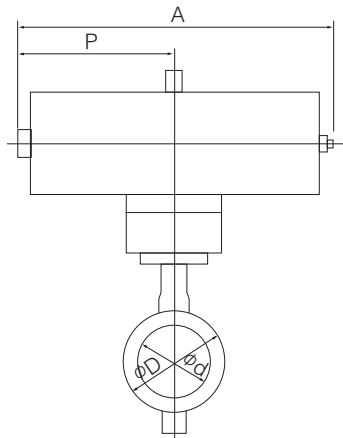

304A-7G

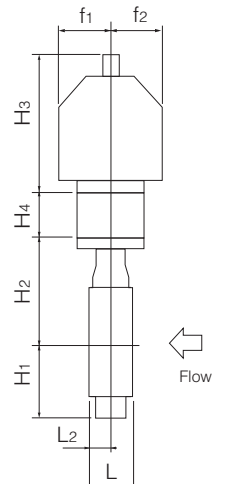
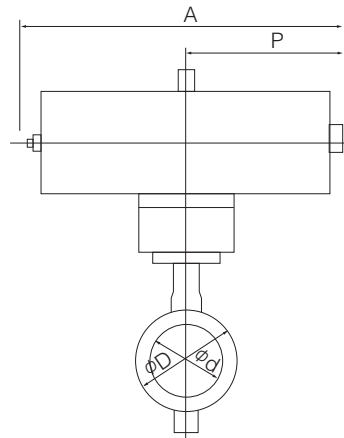

Single-acting pneumatic cylinder type 302Y-7G (Air to open: 40mm to 150mm) / 302Y-7F (Air to close: 40mm to 150mm)
 304Y-7G (Air to open: 40mm to 200mm) / 304Y-7F (Air to close: 40mm to 200mm)

Butterfly Valve
TRITEC
TT2
334A
344Q
302A/303Q
304A/304Q
304YA
302Y/304Y
304M (HLV)
507V/508V
DTM
846T/847T/847Q
841T/842T
700Z
700G/704G/705G
72WG/72SG/72LG
731P/732P/732Q/752W
731R
700E/700K/700S
704G/722F/720F
227P
907T/908H (MKT)
903L/901C/905C (Beta-check)

■ 302Y-7G/7F

Nominal size		Dimension (mm)													Cylinder type	Approx. Mass (kg)
mm	inch	φd	φD	L	L ₂	H ₁	H ₂	Category	H ₃	H ₄	A	P	f ₁	f ₂		
40	1 1/2	48	81	33	15	64	118	T _L ,T _H	203	26.5	449	226	79	57	T200S	14
50	2	60	97	43	21	74	125	T _L	203	26.5	449	226	79	57	T200S	14
								T _H	231	26.5	550	276	91	69	T380S	23
65	2 1/2	74	117	46	22	85	138	T _L	203	26.5	449	226	79	57	T200S	15
								T _H	231	26.5	550	276	91	69	T380S	24
80	3	89	127	46	21	95	147	T _L ,T _H	231	26.5	550	276	91	69	T380S	25
100	4	112	152	52	22	110	170	T _L	231	26.5	550	276	91	69	T380S	26
								T _H	269	26.5	723	360	118	85	T750S	40
125	5	137	183	56	24	139	185	T _L ,T _H	269	26.5	723	360	118	85	T750S	43
150	6	163	213	57	23	164	205	T _L	269	29.5	723	360	118	85	T750S	47

■ 304Y-7G/7F

Nominal size		Dimension (mm)													Cylinder type	Approx. Mass (kg)
mm	inch	φd	φD	L	L ₂	H ₁	H ₂	Category	H ₃	H ₄	A	P	f ₁	f ₂		
40	1 1/2	48	81	33	15	64	118	T ₁₀ ,T ₂₀	168	26.5	364	183	75	47	T85S	10
50	2	60	97	43	21	74	125	T ₁₀ ,T ₂₀	168	26.5	364	183	75	47	T85S	10
65	2 1/2	74	117	46	22	85	138	T ₁₀	168	26.5	364	183	75	47	T85S	11
								T ₂₀	203	26.5	449	226	79	57	T200S	15
80	3	89	127	46	21	95	147	T ₁₀ ,T ₂₀	203	26.5	449	226	79	57	T200S	17
100	4	112	152	52	22	110	170	T ₁₀	203	26.5	449	226	79	57	T200S	18
								T ₂₀	231	26.5	550	276	91	69	T380S	26
125	5	137	183	56	24	139	185	T ₁₀	231	26.5	550	276	91	69	T380S	29
								T ₂₀	269	26.5	723	360	118	85	T750S	43
150	6	163	213	57	23	164	205	T ₁₀ ,T ₂₀	269	29.5	723	360	118	85	T750S	47
200	8	213	263	62	26	190	235	T ₁₀	269	29.5	723	360	118	85	T750S	53

■ 7F Installation direction

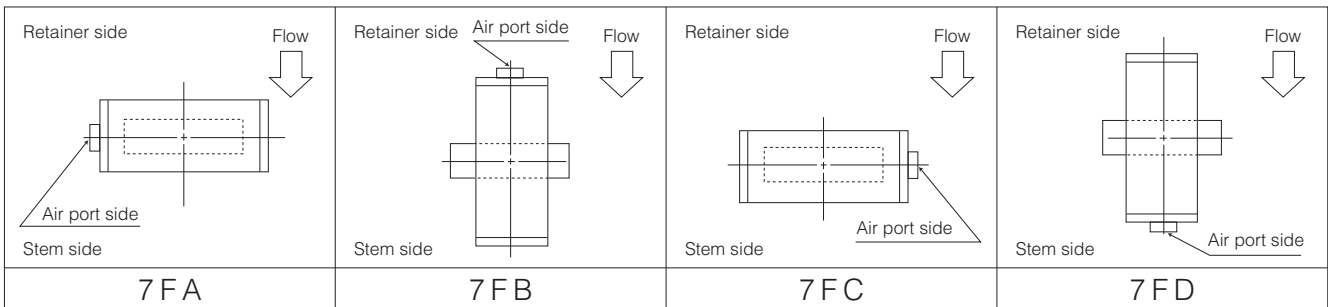

■ 7G Installation direction

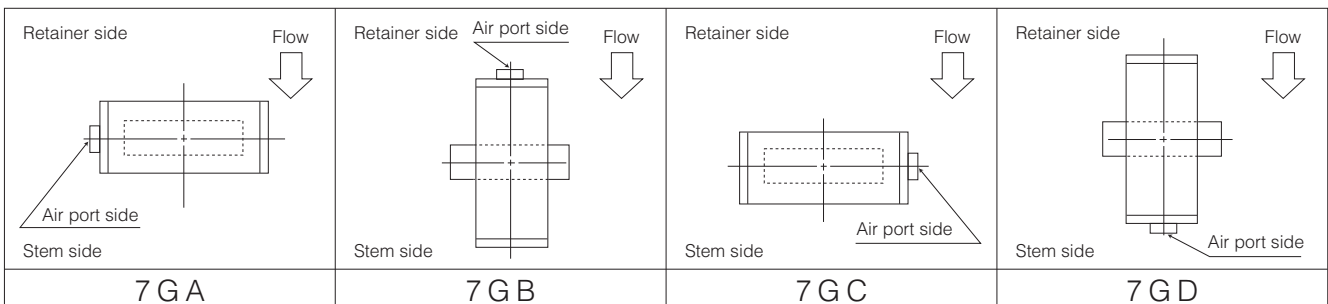

Tom Disco 302Y/304Y

Single-acting pneumatic cylinder type 302Y-3U (Air to open: 150mm to 300mm) / 302Y-3K (Air to close: 150mm to 300mm)
 304Y-3U (Air to open: 200mm to 300mm) / 304Y-3K (Air to close: 200mm to 300mm)

302Y-3U/3K

Nominal size		Dimension (mm)												Cylinder type	Approx. Mass (kg)
mm	inch	ϕd	ϕD	L	L ₂	H ₁	H ₂	Category	H ₃	A	P	f ₁	f ₂		
150	6	163	213	57	23	164	205	T _L	377	945	585	75	165	TG-10S	70
								T _H	377	1080	720	94	206	TG-12S	116
200	8	213	263	62	26	190	235	T _L , T _H	377	1080	720	94	206	TG-12S	122
250	10	263	325	70	30	236	283	T _L , T _H	450	1255	865	131	257	TG-14S	238
300	12	315	368	80	34	246	310	T _L , T _H	450	1255	865	131	257	TG-14S	245

304Y-3U/3K

Nominal size		Dimension (mm)												Cylinder type	Approx. Mass (kg)
mm	inch	ϕd	ϕD	L	L ₂	H ₁	H ₂	Category	H ₃	A	P	f ₁	f ₂		
200	8	213	263	62	26	190	235	T ₁₀	377	945	585	75	165	TG-10S	77
								T ₂₀	377	1080	720	94	206	TG-12S	122
250	10	263	325	70	30	236	283	T ₁₀ , T ₂₀	417	1080	720	94	206	TG-12S	137
300	12	315	368	80	34	246	310	T ₁₀ , T ₂₀	417	1080	720	94	206	TG-12S	144

302Y/304Y-3K

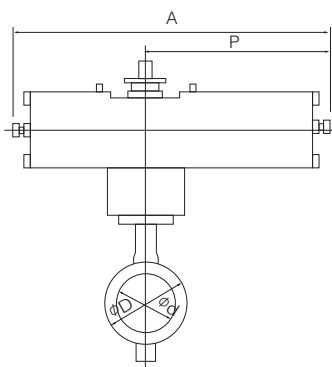

302Y/304Y-3U

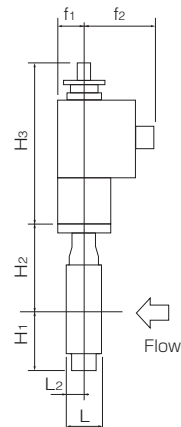
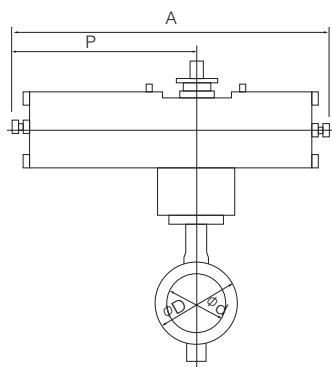

3K Installation direction

<p>Retainer side</p> <p>Flow</p> <p>Stem side</p> <p>3 K A</p>	<p>Retainer side</p> <p>Flow</p> <p>Stem side</p> <p>3 K B</p>	<p>Retainer side</p> <p>Flow</p> <p>Stem side</p> <p>3 K C</p>	<p>Retainer side</p> <p>Flow</p> <p>Stem side</p> <p>3 K D</p>
--	--	--	--

3U Installation direction

<p>Retainer side</p> <p>Flow</p> <p>Stem side</p> <p>3 U A</p>	<p>Retainer side</p> <p>Flow</p> <p>Stem side</p> <p>3 U B</p>	<p>Retainer side</p> <p>Flow</p> <p>Stem side</p> <p>3 U C</p>	<p>Retainer side</p> <p>Flow</p> <p>Stem side</p> <p>3 U D</p>
--	--	--	--

Single phase electric motor type 302Y/304Y-4 I (40mm to 300mm)

■ 302Y-4 I

Nominal size		Dimension (mm)												Motor type	Approx. Mass (kg)
mm	inch	φd	φD	L	L ₂	H ₁	H ₂	Category	H ₃	A	P	F	K		
40	1 1/2	48	81	33	15	64	118	T _L ,T _H	250	202	100	85	54	4I-0	9.4
50	2	60	97	43	21	74	125	T _L ,T _H	250	202	100	85	54	4I-0	9.8
65	2 1/2	74	117	46	22	85	138	T _L	250	202	100	85	54	4I-0	10.8
								T _H	265	252	138	126	65	4I-1	13
80	3	89	127	46	21	95	147	T _L ,T _H	298	310	167	154	85	4I-2	20
100	4	112	152	52	22	110	170	T _L ,T _H	298	310	167	154	85	4I-2	21
125	5	137	183	56	24	139	185	T _L ,T _H	298	310	167	154	85	4I-2	24
150	6	163	213	57	23	164	205	T _L ,T _H	373	310	167	154	85	4I-2.5	31
200	8	213	263	62	26	190	235	T _L ,T _H	405	421.5	223	246	136	4I-3	48
250	10	263	325	70	30	236	283	T _L ,T _H	420	421.5	223	246	136	4I-3	65
300	12	315	368	80	34	246	310	T _L (Remark)	420	421.5	223	246	136	4I-3	72
								T _H	423	421.5	223	246	136	4I-4	77

Remark: For the 300mm model with the accessories on the right (for control) type 4I-4 should be selected. ● Microm unit ● Servo unit ● Speed control unit ● Potentiometer

■ 304Y-4 I

Nominal size		Dimension (mm)												Motor type	Approx. Mass (kg)
mm	inch	φd	φD	L	L ₂	H ₁	H ₂	Category	H ₃	A	P	F	K		
40	1 1/2	48	81	33	15	64	118	T ₁₀ ,T ₂₀	250	202	100	85	54	4I-0	9.4
50	2	60	97	43	21	74	125	T ₁₀ ,T ₂₀	250	202	100	85	54	4I-0	9.8
65	2 1/2	74	117	46	22	85	138	T ₁₀ ,T ₂₀	250	202	100	85	54	4I-0	10.8
80	3	89	127	46	21	95	147	T ₁₀ ,T ₂₀	250	202	100	85	54	4I-0	11.8
100	4	112	152	52	22	110	170	T ₁₀	265	252	138	126	65	4I-1	15
								T ₂₀	298	310	167	154	85	4I-2	21
125	5	137	183	56	24	139	185	T ₁₀ ,T ₂₀	298	310	167	154	85	4I-2	24
150	6	163	213	57	23	164	205	T ₁₀ ,T ₂₀	373	310	167	154	85	4I-2	29
200	8	213	263	62	26	190	235	T ₁₀ ,T ₂₀	373	310	167	154	85	4I-2.5	38
250	10	263	325	70	30	236	283	T ₁₀	411	310	167	154	85	4I-2.5	55.5
								T ₂₀	420	421.5	223	246	136	4I-3	65
300	12	315	368	80	34	246	310	T ₁₀ ,T ₂₀	420	421.5	223	246	136	4I-3	72

■ 302Y/304Y-4 I

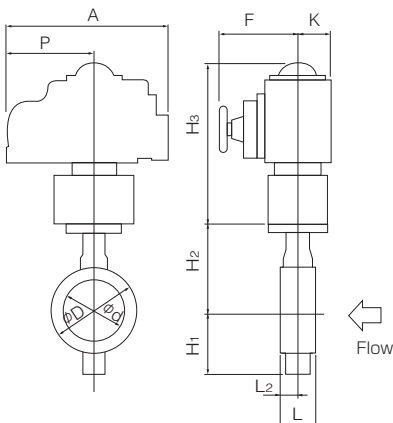

■ 4I Installation direction

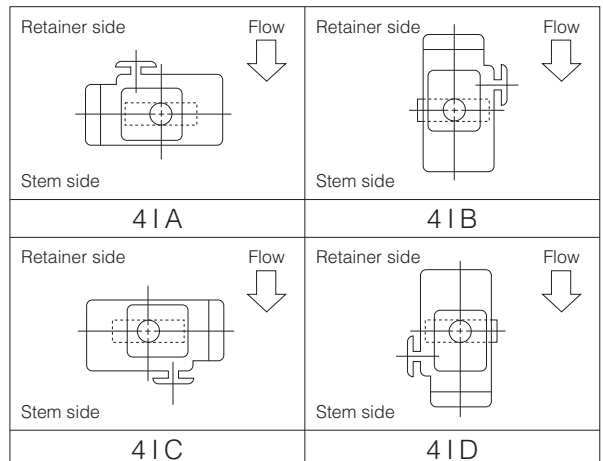

Butterfly Valve
TRITEC
TT2
334A
344Q
302A/303Q
304A/304Q
304YA
302Y/304Y
304M (HLV)
507V/508V
DTM
846T/847T/847Q
841T/842T
700Z
700G/704G/705G
72WG/72SG/72LG
731P/732P/732Q/752W
731R
700E/700K/700S
704G/722F/720F
227P
907T/908H (MKT)
903L/901C/905C (Beta-check)

Tom Disco 302Y/304Y

Three phase motor actuator type 302Y-4L (250mm, 300mm)

302Y-4L

Nominal size		Dimension (mm)													Motor type	Approx. Mass (kg)
mm	inch	ϕd	ϕD	L	L ₂	H ₁	H ₂	Category	H ₃	E	K	F	M	P		
250	10	263	325	70	30	236	283	T _L ,T _H	547	117	164	533	357	230	LTKD-01 0.2kW/ DGH-3	123
300	12	315	368	80	34	246	310	T _L ,T _H	547	117	164	533	357	230	LTKD-01 0.2kW/ DGH-3	130

302Y-4L

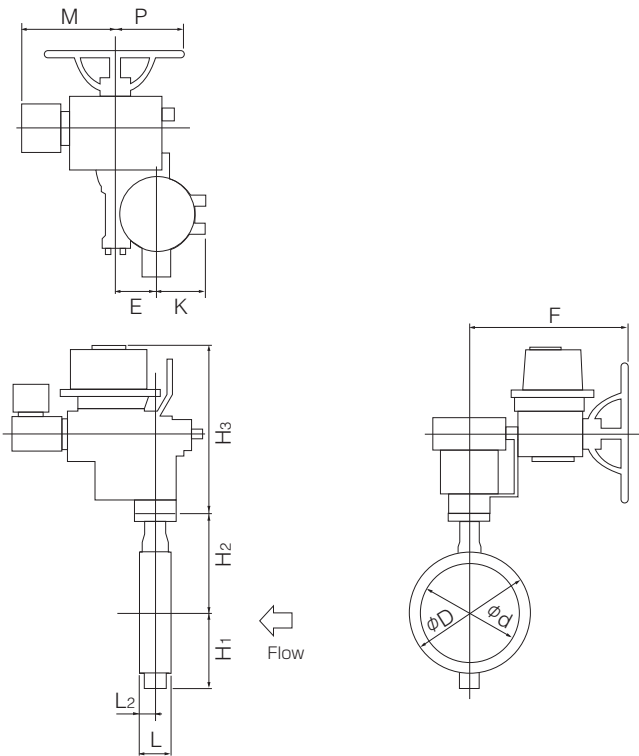

4L Installation direction

<p>Retainer side</p> <p>Flow</p> <p>Stem side</p> <p>4 L A</p>	<p>Retainer side</p> <p>Flow</p> <p>Stem side</p> <p>4 L B</p>	<p>Retainer side</p> <p>Flow</p> <p>Stem side</p> <p>4 L C</p>	<p>Retainer side</p> <p>Flow</p> <p>Stem side</p> <p>4 L D</p>
--	--	--	--

302Y/304Y Cv value/pressure loss coefficient

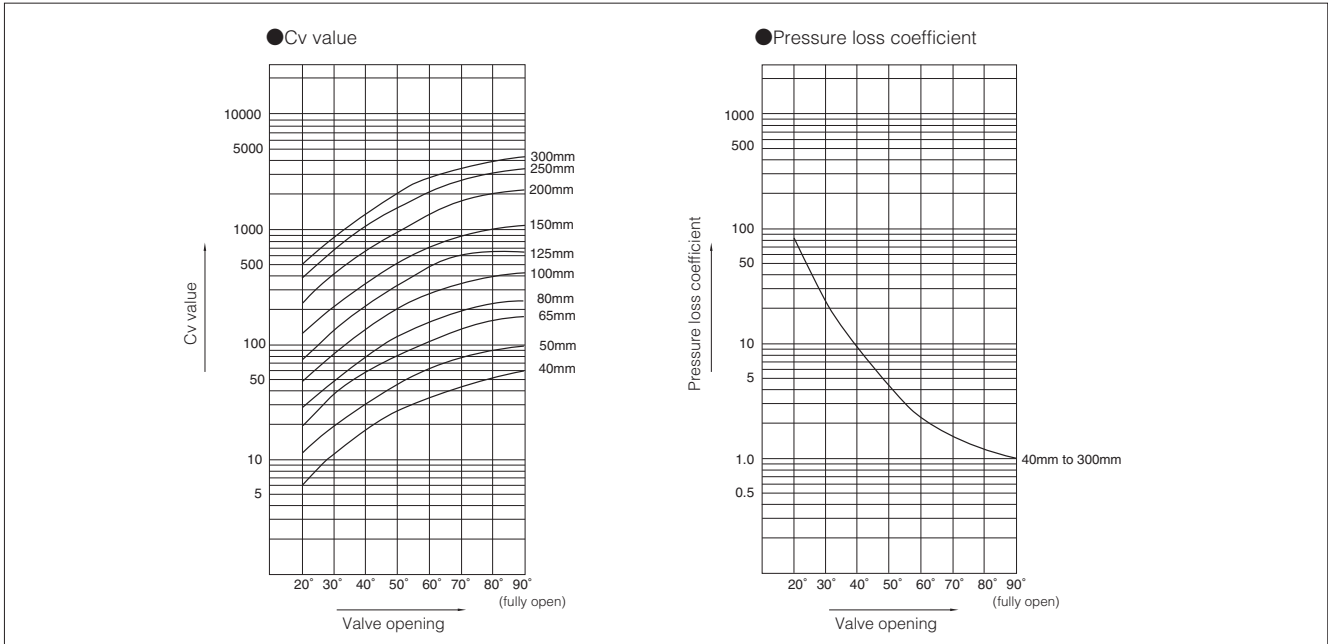

Butterfly Valve

TRITEC

TT2

334A

344Q

302A/303Q

304A/304Q

304YA

302Y/304Y

304M (HLV)

507V/508V

DTM

846T/847T/847Q

841T/842T

700Z

700G/704G/705G

72WG/72SG/72LG

731P/732P/732Q/752W

731R

700E/700K/700S

704G/722F/720F

227P

907T/908H (MKT)

903L/901C/905C (Bata-check)

302Y/304Y Cv value

Nominal size		Valve opening							
mm	inch	20°	30°	40°	50°	60°	70°	80°	90°
40	1 1/2	6	12	20	30	39	49	57	60
50	2	11	21	33	49	64	80	95	99
65	2 1/2	20	36	59	85	113	140	167	176
80	3	29	52	85	122	162	207	243	252
100	4	49	88	144	207	279	351	414	432
125	5	77	140	230	333	441	549	648	684
150	6	126	225	369	531	720	900	1080	1116
200	8	234	423	693	990	1350	1710	1982	2070
250	10	390	703	1148	1648	2244	2857	3300	3443
300	12	492	888	1454	2081	2838	3612	4172	4354

302Y/304Y Pressure loss coefficient

Nominal size		Valve opening							
mm	inch	20°	30°	40°	50°	60°	70°	80°	90°
40	1 1/2	178	44	16	7	4	3	2	2
50	2	138	42	15	7	4	3	2	2
65	2 1/2	114	35	13	6	4	2	2	1
80	3	108	34	13	6	3	2	2	1
100	4	109	34	13	6	3	2	2	1
125	5	106	32	12	6	3	2	1	1
150	6	78	25	9	4	2	2	1	1
200	8	69	21	8	4	2	1	1	1
250	10	59	18	7	3	2	1	1	1
300	12	76	23	9	4	2	1	1	1

Tom Disco 302Y/304Y

302Y/304Y Applicable pipe list in case of **A**

Nominal size		SGP		Sch20		Sch40		Sch60		Sch80		Sch10S		Sch20S		Minimum internal diameters of piping (mm)
		Retainer (up stream)	Stem Side (down stream)	Retainer (up stream)	Stem Side (down stream)	Retainer (up stream)	Stem Side (down stream)	Retainer (up stream)	Stem Side (down stream)	Retainer (up stream)	Stem Side (down stream)	Retainer (up stream)	Stem Side (down stream)	Retainer (up stream)	Stem Side (down stream)	
mm	inch															
40	1 1/2	○	○	—	—	○	○	○	○	○	○	○	○	○	○	32.7
50	2	○	○	○	○	○	○	○	○	○	○	○	○	○	○	34.6
65	2 1/2	○	○	○	○	○	○	○	○	○	○	○	○	○	○	53.6
80	3	○	○	○	○	○	○	○	○	○	○	○	○	○	○	72.5
100	4	○	○	○	○	○	○	○	○	○	○	○	○	○	○	93.8
125	5	○	○	○	○	○	○	○	○	○	○	○	○	○	○	119.4
150	6	○	○	○	○	○	○	○	×	○	×	○	○	○	○	147.5
200	8	○	○	○	○	○	○	○	×	○	×	○	○	○	○	197.5
250	10	○	○	○	○	○	○	○	×	○	×	○	○	○	○	248.1
300	12	○	○	○	○	○	○	○	×	×	×	○	○	○	○	297.6

302Y/304Y Applicable pipe list in case of **B**

Nominal size		SGP		Sch20		Sch40		Sch60		Sch80		Sch10S		Sch20S		Minimum internal diameters of piping (mm)
		Retainer (up stream)	Stem Side (down stream)	Retainer (up stream)	Stem Side (down stream)	Retainer (up stream)	Stem Side (down stream)	Retainer (up stream)	Stem Side (down stream)	Retainer (up stream)	Stem Side (down stream)	Retainer (up stream)	Stem Side (down stream)	Retainer (up stream)	Stem Side (down stream)	
mm	inch															
40	1 1/2	○	○	—	—	○	○	○	○	○	○	○	○	○	○	20.0
50	2	○	○	○	○	○	○	○	○	○	○	○	○	○	○	25.0
65	2 1/2	○	○	○	○	○	○	○	○	○	○	○	○	○	○	40.0
80	3	○	○	○	○	○	○	○	○	○	○	○	○	○	○	63.6
100	4	○	○	○	○	○	○	○	○	○	○	○	○	○	○	87.0
125	5	○	○	○	○	○	○	○	○	○	○	○	○	○	○	112.8
150	6	○	○	○	○	○	○	○	○	○	○	○	○	○	○	142.5
200	8	○	○	○	○	○	○	○	×	○	×	○	○	○	○	193.3
250	10	○	○	○	○	○	○	○	×	○	×	○	○	○	○	244.1
300	12	○	○	○	○	○	○	○	×	○	×	○	○	○	○	293.9

Remark 1: ○=Applicable ×=Not applicable

Remark 2: The clearance between the disc and the pipe is based on API 609 and MSS SP-67.
40mm to 150mm: 1.5mm; 200mm to 300mm: 3.0mm

Remark 3: Butterfly valves are inserted into a pipe that was fitted with the disc when fully open.
In cases where there is an "X" in the chart above or you are using a pipe or flange that is less than the minimum inner pipe diameter, use is still possible if means are taken such as inserting a spacer between the valve and flange.
For details, please consult us.

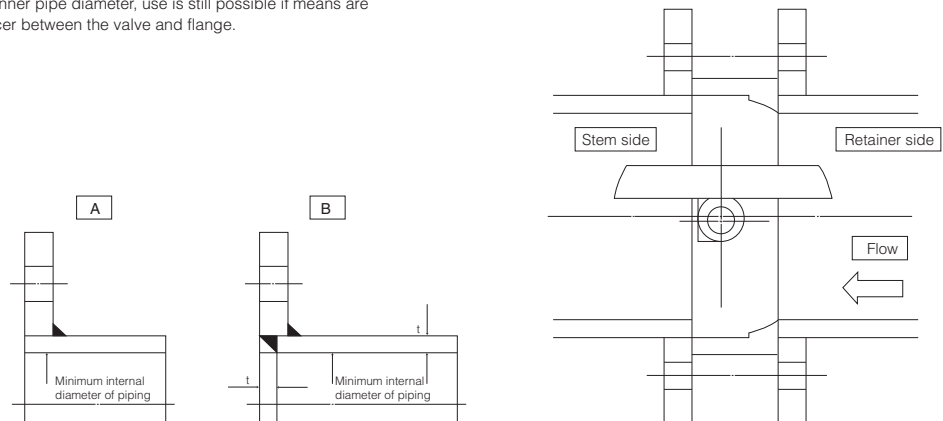

302Y/304Y Piping gasket

- In case of sheet gasket Any standard can be used excluding 65mm-JIS flange. For 65mm-JIS flange, use the sheet gasket that followed old JIS Standard: JIS B 2404_1999 for inner diameter. For other size, JIS standard products can be used.
- In case of spiral gasket Use special spiral gasket shown below.

■ Special spiral gasket for JIS flange size

Nominal size		JIS flange					ASME flange				
		10K, 16K, 20K			10K	16K, 20K	class 150/300			class 150	class 300
mm	inch	D ₁	D ₂	D ₃	D ₄	D ₄	D ₁	D ₂	D ₃	D ₄	D ₄
40	1 1/2	48	54	73	89	89	48	54	73	85	95
50	2	61	69	88	104	104	61	69	88	104	111
65	2 1/2	73	81	100	124	124	73	81	100	123	129
80	3	89	97	120	134	140	89	97	120	136	148
100	4	115	124	146	159	165	115	124	146	174	180
125	5	140	151	177	190	203	140	151	177	196	215
150	6	166	178	207	220	237	166	178	207	222	250
200	8	217	227	257	270	282	217	229	257	279	307
250	10	268	282	318	332	354	268	285	318	339	362
300	12	319	331	362	377	404	319	335	362	409	422

Remark : In case a minute leakage of gas (less than 100PPm) becomes a problem, please consult our sales staff.

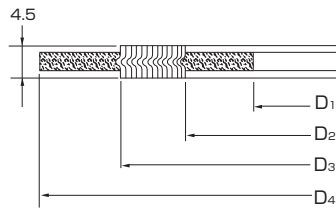

■ Applicable standard for standard piping gasket

Nominal size		Max. allowable inner diameter (D)	Joint sheet or RPTFE solid gasket (t≤2mm)					PTFE mold type gasket				
			JIS 5K	JIS 10K	JIS 16K JIS 20K	ASME class 150/300	JPI class 150/300	Valqua: 7030, 7031or 7035				
mm	inch		JIS 5K	JIS 10K	JIS 16K JIS 20K	ASME class 150/300	JPI class 150/300	JIS 5K	JIS 10K	JIS 16K JIS 20K	ASME class 150/300	JPI class 150/300
40	1 1/2	55	○	○	○	○	○	○	○	○	○	○
50	2	69	○	○	○	○	○	○	○	○	○	○
65	2 1/2	77	×	×	×	○	○	×	×	×	○	○
80	3	97	○	○	○	○	○	○	○	○	○	○
100	4	124	○	○	○	○	○	○	○	○	○	○
125	5	151	○	○	○	○	○	○	○	○	○	○
150	6	178	○	○	○	○	○	○	○	○	○	○
200	8	227	○	○	○	○	○	○	○	○	○	○
250	10	282	○	○	○	○	○	○	○	○	○	○
300	12	331	○	○	○	○	○	○	○	○	○	○

Remark; ○: Applicable, ×: Not applicable

Remark : The above gaskets is not applicable to JIS piping 65mm. When using a gasket for JIS piping 65mm, make sure that the inner diameter of the gasket is 77 mm. PTFE mold type gasket made by NIPPON VALQUA is only available. (Other manufacturer's gasket is not applicable due to product size.)

Butterfly Valve
TRITEC
TT2
334A
344Q
302A/303Q
304A/304Q
304YA
302Y/304Y
304M (HLV)
507V/508V
DTM
846T/847T/847Q
841T/842T
700Z
700G/704G/705G
72WG/72SG/72LG
731P/732P/732Q/752W
731R
700E/700K/700S
704G/722F/720F
227P
907T/908H (MKT)
903L/901C/905C (Bata-check)

Tom Disco 302Y/304Y

302Y/304Y Flange accommodation

Nominal size		JIS				ASME class 150	BS4504		DIN		BS10 Table E
mm	inch	5K	10K	16K	20K		PN10	PN16	NP10	NP16	
40	1 1/2	○	○	○	○	○	○	○	○	○	
50	2	○	○	○	○	○	○	○	○	○	
65	2 1/2	○	○	○	○	○	○	○	○	×	
80	3	○	○	○	○	○	○	○	○	○	
100	4	○	○	○	○	○	○	○	○	○	
125	5	○	○	○	○	○	○	○	○	○	
150	6	○	○	○	○	○	○	○	○	○	
200	8	○	○	○	○	○	○	○	○	○	
250	10	○	○	○	○	○	○	○	○	○	
300	12	○	○	○	○	○	○	○	○	○	

○ : Can be used without flange drilling.
 × : Not applicable

302Y/304Y Piping bolts and nuts sizes

Nominal size		JIS5K	JIS10K	JIS16K/20K	ASME class150
mm	inch	Long bolts and nuts	Long bolts and nuts	Long bolts and nuts	Long bolts and nuts
40	1 1/2	4-M12×100	4-M16×120	4-M16×120	4-U1/2-13UNC×115
50	2	4-M12×120	4-M16×130	8-M16×130	4-U5/8-11UNC×140
65	2 1/2	4-M12×120	4-M16×145	8-M16×145	4-U5/8-11UNC×155
80	3	4-M16×130	8-M16×145	8-M20×170	4-U5/8-11UNC×155
100	4	8-M16×145	8-M16×145	8-M20×170	8-U5/8-11UNC×155
125	5	8-M16×145	8-M20×170	8-M22×190	8-U3/4-10UNC×175
150	6	8-M16×145	8-M20×170	12-M22×190	8-U3/4-10UNC×175
200	8	8-M20×170	12-M20×170	12-M22×190	8-U3/4-10UNC×205
250	10	12-M20×190	12-M22×190	12-M24×210	12-U7/8- 9UNC×215
300	12	12-M20×190	16-M22×190	16-M24×225	12-U7/8- 9UNC×215

Remark: Bolt / nut material: SNB7 / S45C (manufacturer standard product), SUS304 / SUS304 (order-made product) Spiral gasket cannot be used. Use full-thread bolts for long bolts and heavy nuts for hexagon nuts.

Example

Long bolts: 12 - M22 × 185
 | | |
 N M L

Long bolts and nuts (full thread)

