

TGA

The TGA model is a double-action pneumatic actuator perfect for on/off control of the various types of butterfly valves. With an optional positioner, it can also be used for flow rate control. It mainly used for the medium to large-sized valves of size 350mm or more. The operation principle is that air pressure forces the piston inside the cylinder into a linear reciprocating motion, causing the trunnion coupled to the rod to drive the arm and rotate the output shaft.

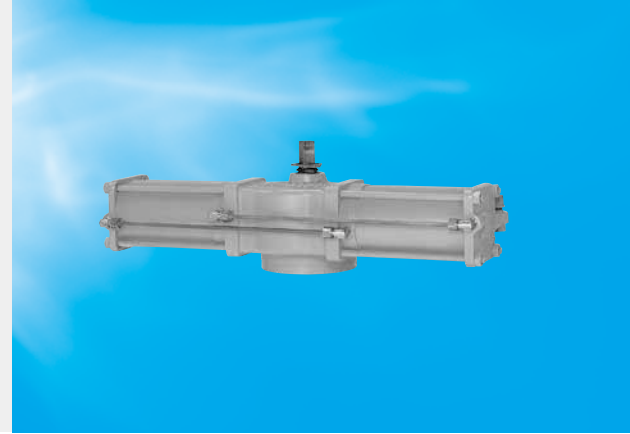

TGA Specifications								
	TGA-100	TGA-125	TGA-140	TGA-160	TGA-180	TGA-200	TGA-220	TGA-250
Output torque (N·m) (When supply pressure is 0.4 MPa and rotation angle is 0° or 90°)	585	1069	1510	2274	3194	4339	5976	8619
Supply pressure (MPa)	0.4~0.7* ¹							
Body shell max (MPa)	1.0							
Rotating angle	0 to +90°							
Port size	Rc1/4	Rc3/8				Rc1/2		
Operating fluid	Dry air							
Ambient temperature / supply air temperature	0 to 80 degree C* ²							
Rotating speed range (sec.)	5 to 15							
Coating	Epoxy primer finish (Munsell N7)							

※1 If used for the TRITEC(TT1, TT2) with over 0.5MPa supply pressure, and forecasting over 10,000 times operation. Please ask us about cylinder specifications.

※2 Please ask us when used at working temperature of more than 60 degree C.

TGA Outer Dimensions

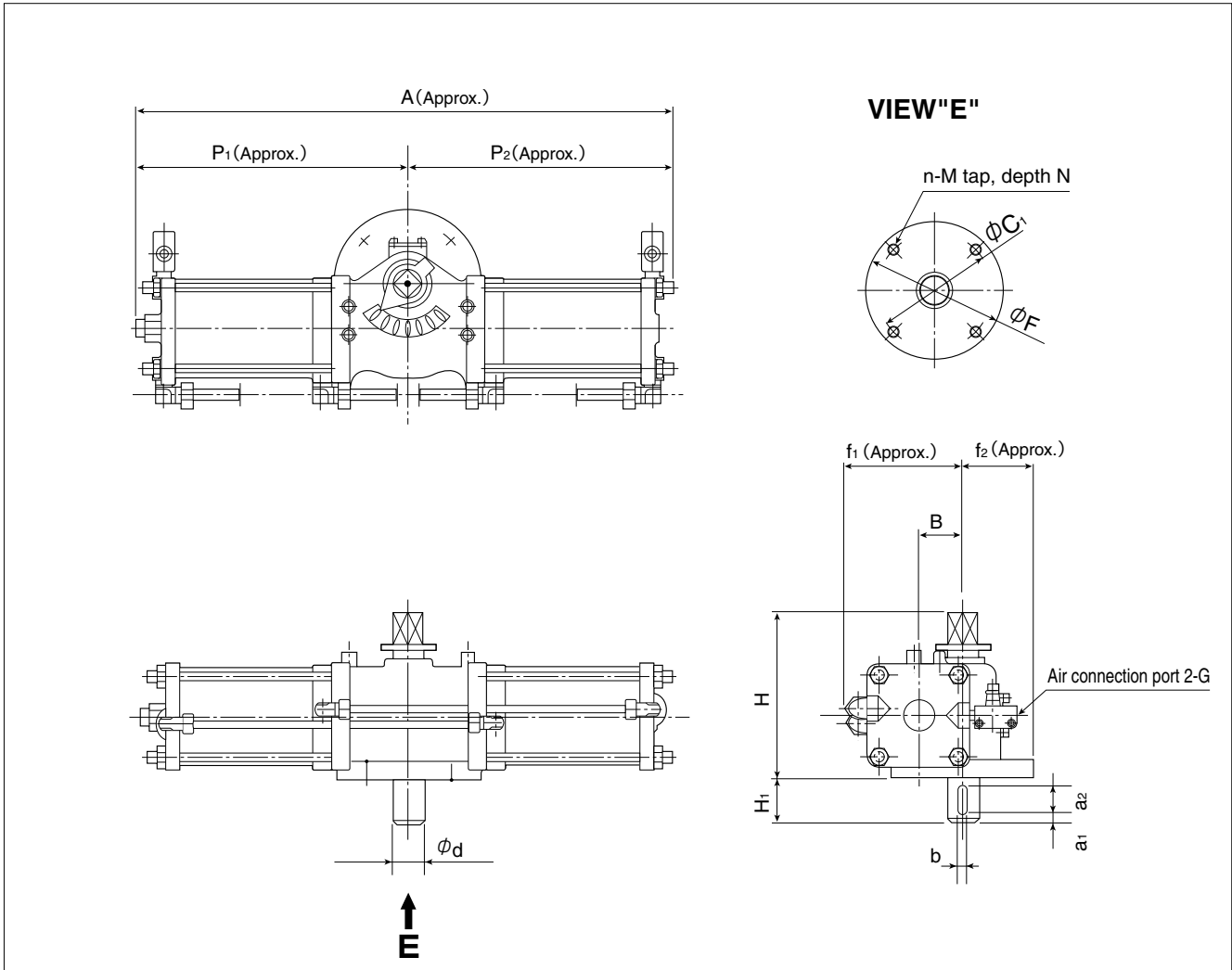

TGA Dimensions

Type	Dimension (mm)																	Approx. Mass (kg)	
	A	P ₁	P ₂	f ₁	f ₂	B	H	H ₁	ϕ_d	b	a ₁	a ₂	ϕF	C ₁	n	M	N		G
TGA-100	682	350	332	133	77.5	50	189	45	30	10	2	40	155	125	4	M12	15	Rc1/4	18
TGA-125	754	381	373	164	100	62	234	45	40	12	2	40	200	170	4	M16	20	Rc3/8	31
TGA-140	840	432	408	180	100	70	282	60	45	12	2	55	200	170	4	M16	20	Rc3/8	40
TGA-160	964	483	471	202	130	80	310	61	60	15	2	55	260	220	4	M20	25	Rc3/8	84
TGA-180	1069	543	526	221	130	90	323	65	65	18	2	60	260	220	4	M20	25	Rc3/8	115
TGA-200	1175	599	576	254	160	100	370	70	75	20	2	65	320	280	8	M20	25	Rc1/2	164
TGA-220	1263	642	621	271	160	110	400	85	75	20	2	80	320	280	8	M20	25	Rc1/2	188
TGA-250	1392	707	687	302	160	125	433	100	75	20	2	95	320	280	8	M20	25	Rc1/2	254

TGA Operation principle

As chambers A1 - A2 and B1 - B2 are connected through copper tubes as shown in the figure at left (single-acting cylinder is provided only with chambers A2 and B1), feeding air into port "S" will generate a thrust to push the piston toward the left. The linear motion of the piston is converted to a clockwise rotary motion of the output shaft through the trunnion. Residual air in chamber B is exhausted through port "O". Feeding air to port "O" causes the reverse of the action described above, rotating the output shaft counter-clockwise.

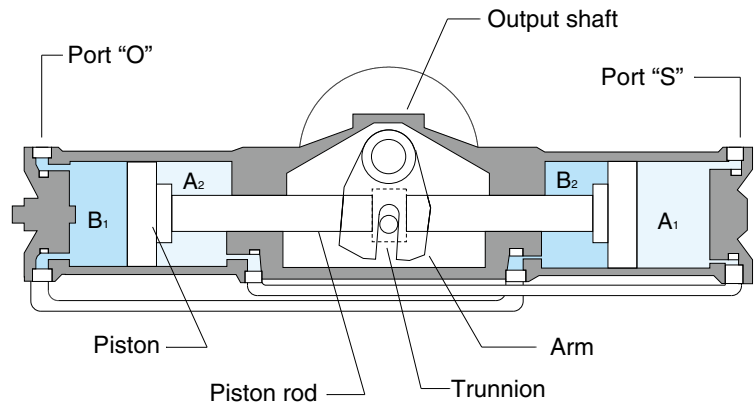

TGA Air consumption

Type	Cylinder capacity (ℓ)	
	A (O→S)	B (S→O)
TGA-100	1.980	1.980
TGA-125	3.629	3.629
TGA-140	5.113	5.113
TGA-160	7.713	7.713
TGA-180	10.847	10.847
TGA-200	14.730	14.730
TGA-220	20.229	20.229
TGA-250	29.278	29.278

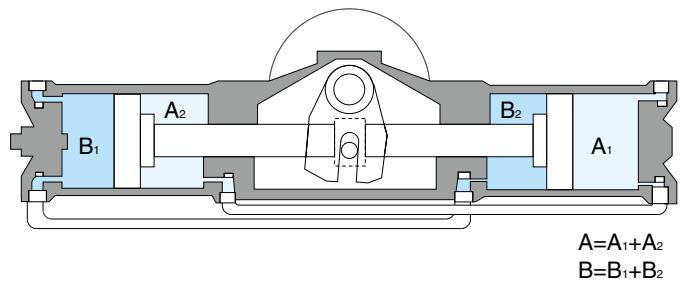

(1) Required air consumption

Double-acting type

$$VD=(A+B) \left(\frac{P-0.1013}{0.1013} \right) N$$

VD : Double-acting type cylinder air consumption (N ℓ)

A, B : Cylinder capacity (ℓ)

P : Working pressure (Mpa)

N : Operating frequencies in a given time (1 round trip=1)

(2) Air consumption within a unit time

Double-acting type $CD= \frac{VD}{t}$

CD : Double-acting type cylinder air consumption (Nℓ/sec)

t : Unit time (sec)

Remark: The compressor should have a larger capacity than the air consumption calculated above in (1) and (2).

TGA Output Torque Curve

Double-acting type (TGA)

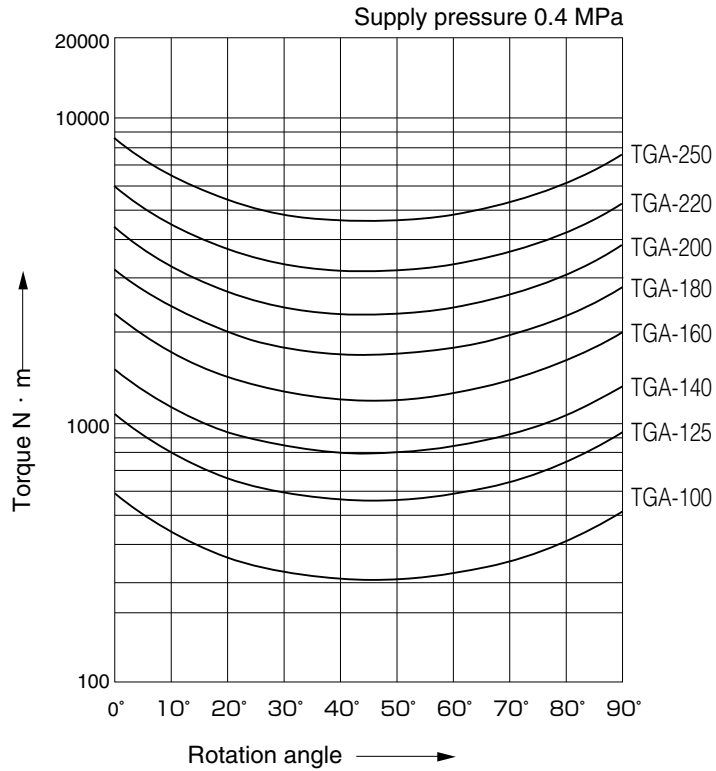

Notes :

- — Lines show output torque curve by actuator
- The table shows the torque at an operating air pressure of 0.4 Mpa.

TGA Output Torque

Type	Rotation angle (°)									
	0	10	20	30	40	50	60	70	80	90
TGA-100	585	447	367	325	310	311	324	355	413	507
TGA-125	1069	815	669	593	565	567	591	648	754	926
TGA-140	1510	1153	946	838	799	801	836	916	1065	1308
TGA-160	2274	1735	1423	1262	1203	1206	1259	1379	1604	1969
TGA-180	3194	2437	1999	1771	1689	1693	1767	1936	2253	2766
TGA-200	4339	3311	2716	2406	2295	2301	2401	2630	3060	3758
TGA-220	5977	4561	3742	3317	3163	3172	3309	3625	4216	5176
TGA-250	8620	6579	5398	4784	4562	4574	4773	5228	6081	7466

TGA Expanded view of component

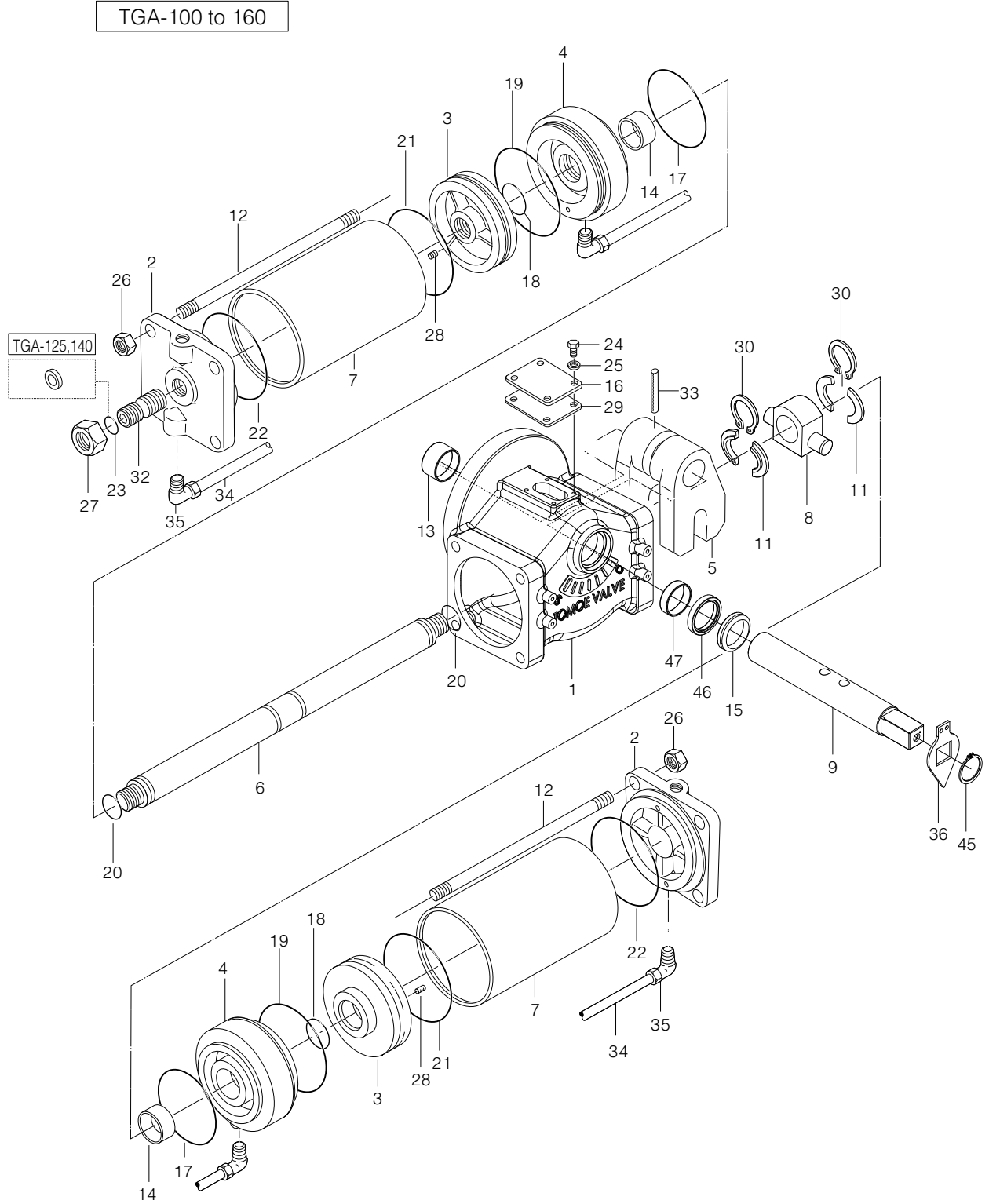

TGA Parts list

■ TGA-100 to 160 parts list (double-acting type)

No.	Description	Q'ty	Remarks
1	Body	1	
2	End cover	2	
3	Piston	2	
4	Rod cover	2	
5	Arm	1	
6	Piston rod	1	
7	Case	2	
8	Trunnion	1	
9	Shaft	1	
11	Rings	Set of 2	
12	Tie rod	8	
13	Bush	1	※1
14	Bush	2	
★ 15	V-ring	1	
16	Cover	1	
★ 17	O-ring	2	
★ 18	O-ring	2	
★ 19	O-ring	2	
★ 20	O-ring	2	
★ 21	O-ring	2	
★ 22	O-ring	2	
★ 23	Seal washer	1	Only TGA-100,125,140
	O-ring		Only TGA-160
24	Hexagon bolt	4	
25	Spring washer	4	
26	Hexagon nut	8	
27	Lock nut	1	
28	Screws	2	
29	Gasket	1	
30	C-retainer	2	
32	Stopper bolt	1	
33	Spring pin	2	
34	Copper pipe	2	
35	Pipe coupler	4	
36	Indicator	1	
45	C-retainer	1	
★ 46	Oil seal	1	※1
47	Bush	1	※1

Remark: Parts with a "star" before the part number are recommended replacement parts. To order as a set, please specify O-ring set.

※1 For products manufactured before May 2012, 2 pieces of parts no.13 are used, and parts no.46 to 47 are not used.

TGA Expanded view of component

TGA-180 to 250

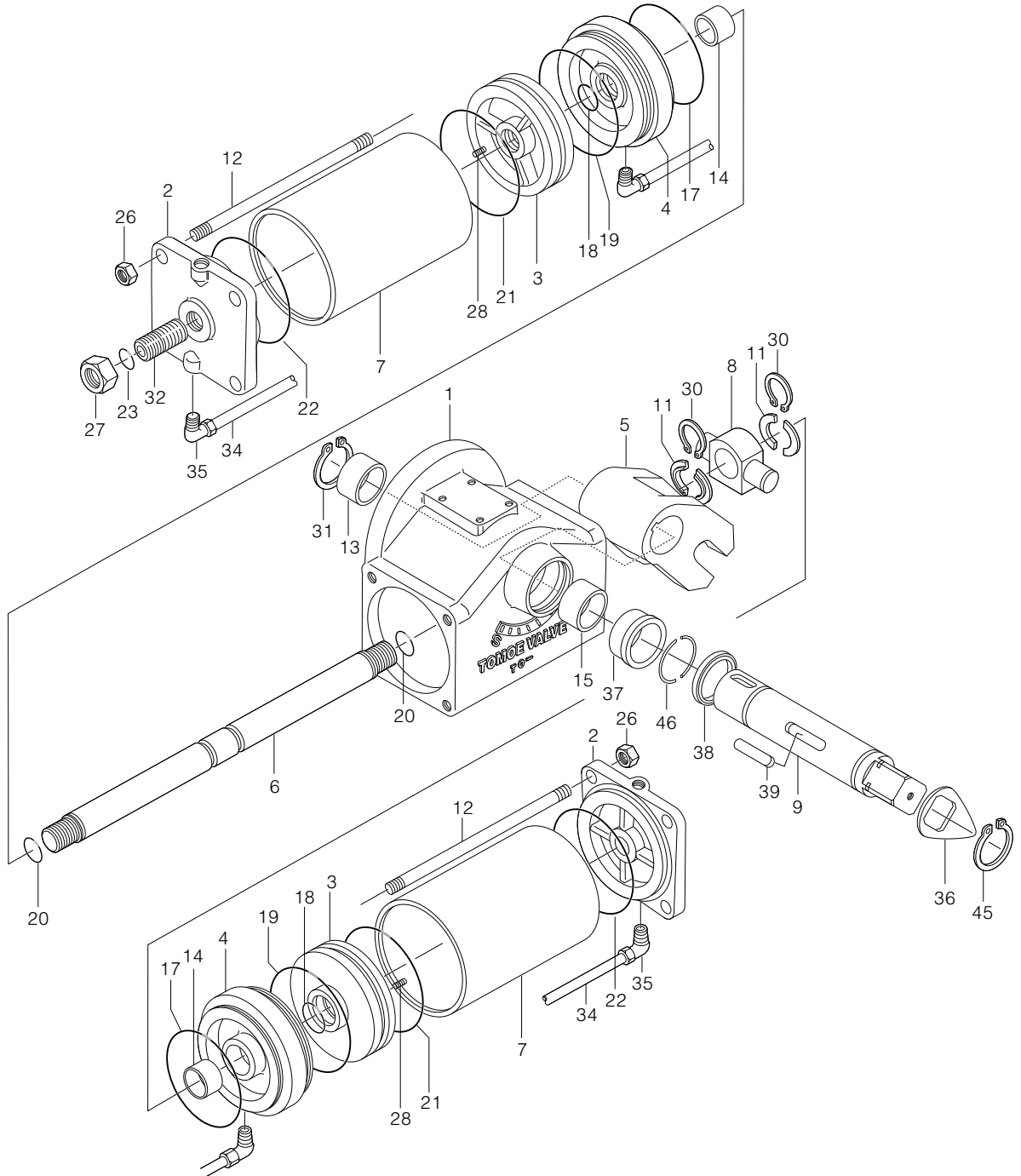

TGA Parts list

■ TGA-180 to 250 parts list (double-acting type)

No.	Description	Q'ty	Remarks
1	Body	1	
2	End cover	2	
3	Piston	2	
4	Rod cover	2	
5	Arm	1	
6	Piston rod	1	
7	Case	2	
8	Trunnion	1	
9	Shaft	1	
11	Rings	Set of 2	
12	Tie rod	8	
13	Bush	1	
14	Bush	2	
15	Bush	1	
★ 17	O-ring	2	
★ 18	O-ring	2	
★ 19	O-ring	2	
★ 20	O-ring	2	
★ 21	O-ring	2	
★ 22	O-ring	2	
★ 23	O-ring	1	
26	Hexagon bolt	8	
27	Lock nut	1	
28	Screws	2	
30	C-retainer	2	
31	C-retainer	1	
32	Stopper bolt	1	
34	Copper pipe	2	
35	Pipe coupler	4	
36	Indicator	1	
37	Bush	1	
★ 38	Oil seal	1	
39	Key	1	
45	C-retainer	1	
46	Stop ring	Set of 1	

Remark: Parts with a "star" before the part number are recommended replacement parts. To order as a set, please specify O-ring set.

TGA Accessories

Accessory	Type	Manu- facturer	Part No.	Double-acting type								
				TGA-100	TGA-125	TGA-140	TGA-160	TGA-180	TGA-200	TGA-220	TGA-250	
Five-port/2-position, non explosion-proof, solenoid valve	Single solenoid	TAIYO	PCS2406-MC	○	—	—	—	—	—	—	—	—
		TAIYO	PCS2408-MC	—	○	○	○	○	○	○	—	—
		TAIYO	PCS2415-MC	—	—	—	—	—	○	○	○	○
	Double solenoid	TAIYO	PCD2406-MC	○	—	—	—	—	—	—	—	—
		TAIYO	PCD2408-MC	—	○	○	○	○	—	—	—	—
		TAIYO	PCD2415-MC	—	—	—	—	—	○	○	○	○
Five-port/2-position, explosion-proof, solenoid valve	Single solenoid	Kaneko	MB15G-8AE12PU-TMS	○	—	—	—	—	—	—	—	—
		Kaneko	MB15G-10AE12PU-TMS	—	○	○	○	○	○	○	○	○
	Double solenoid	Kaneko	MB15DG-8AE12PRS-M-TMS	○	—	—	—	—	—	—	—	—
		Kaneko	MB15DG-10AE12PRS-M-TMS	—	○	○	○	○	○	○	○	○
Filter regulator		SMC	AW20-02B-2-B-X490	○	—	—	—	—	—	—	—	—
		SMC	AW30-03B-2-B-X490	—	○	○	○	○	—	—	—	—
		SMC	AW40-04B-2	—	—	—	—	—	○	○	○	○
Limit switch	Non explosion-proof	Tomoe	TMS-BOX	○	○	○	○	○	○	○	○	○
		Azbil	1LS1-J	○	○	○	○	○	○	○	○	○
		OMRON	WLCA2	○	○	○	○	○	○	○	○	○
	Explosion-proof	Azbil	1LX7001	○	○	○	○	○	○	○	○	○
		Azbil	VCX-7003	○	○	○	○	○	○	○	○	○
Proximity switch	M18 shielded	OMRON	E2E-X7D1-N	○	○	○	○	○	○	○	○	○
	M18 non-shielded	OMRON	E2E-X14MD1	○	○	○	○	○	○	○	○	○
	M30 shielded	OMRON	E2E-X10D1-N	○	○	○	○	○	○	○	○	○
Positioner	Electro-pneumatic	SSS	TCE2000	○	○	○	○	○	○	○	○	○
		SMC	TP8100	○	○	○	○	○	○	○	○	○
		Azbil	AVP300	○	○	○	○	○	○	○	○	○
	Pneumatic-pneumatic	SMC	IP5100	○	○	○	○	○	○	○	○	○
Manual operating	Manual gear unit	Tomoe	MGC	○	○	○	○	○	○	○	○	
Stroke adjuster		Tomoe	—	○	○	○	○	○	○	○	○	
Bypass unit		—	—	○	○	○	○	○	○	○	○	
Speed controller		SMC	AS2000-02	★	—	—	—	—	—	—	—	—
		SMC	AS3000-03	—	★	★	★	★	—	—	—	—
Silencer		SMC	AS4000-04	—	—	—	—	—	★	★	★	—
		SMC	AN20-02	○	○	○	○	○	○	○	○	○
		SMC	AN30-03	○	○	○	○	○	○	○	○	○
		SMC	AN40-04	—	—	—	—	—	○	○	○	○
Lock-up valve		SMC	IL211-02	○	○	○	○	○	○	○	○	
Quick exhaust valve		SMC	AQ2000-02	○	—	—	—	—	—	—	—	—
		SMC	AQ3000-03	—	○	○	○	○	—	—	—	—
		SMC	AQ5000-04	—	—	—	—	—	○	○	○	○
Booster relay		SMC	IL100-02	○	—	—	—	—	—	—	—	—
		SMC	IL100-03	—	○	○	○	○	○	○	○	○
Bypass valve (Ball valve)		TOA	BK-8A	○	—	—	—	—	—	—	—	—
		TOA	BK-10A	—	○	○	○	○	—	—	—	—
Operation recording unit		KKD	651-001-13	—	—	—	—	—	○	○	○	○
		Tomoe	TPro1100	○	○	○	○	○	○	○	○	○

Remarks:

1. Symbols in table mean the following: ★: Standard accessory, ○: Installable, —: Un-installable
2. This table shows typical accessory combinations. Accessories not shown in this table can also be installed. For details, please consult us.

TGA Solenoid valves

■ Purpose

The purpose of a solenoid valve is to use electrical signals to remotely change the air flow to operate the valves.

■ Standard specifications

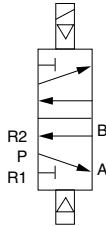
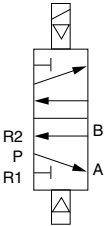
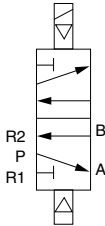
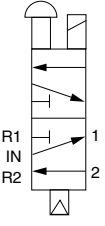
Item	Five-port/2-position, non explosion-proof, solenoid valve (single solenoid)	Five-port/2-position, non explosion-proof, solenoid valve (single solenoid)	Five-port/2-position, non explosion-proof, solenoid valve (single solenoid)	Five-port/2-position, explosion-proof, solenoid valve (single solenoid)
Type	PCS2406-MC	PCS2408-MC	PCS2415-MC	MB15G-10AE12PU-TMS
Manufacturer	TAIYO	TAIYO	TAIYO	Kaneko
JIS symbol				
Applicable cylinder type	TGA-100	TGA-125 to 180	TGA-200 to 250	TGA-125 to 250
Air connection port size	Rc1/4 (IN, OUT, EXH)	Rc3/8 (IN, OUT) Rc1/4 (EXH)	Rc1/2 (IN, OUT) Rc3/8 (EXH)	Rc3/8 (IN, OUT) Rc1/4 (EXH)
Effective sectional area	10mm ²	30mm ²	70mm ²	11mm ²
Rated voltage	AC100V/110V 50/60Hz AC200V/220V 50/60Hz DC24V	AC100V/110V 50/60Hz AC200V/220V 50/60Hz DC24V	AC100V/110V 50/60Hz AC200V/220V 50/60Hz DC24V	AC100V, AC200V 50/60Hz AC110V, AC220V 60Hz DC24V
Explosion-proof construction	-	-	-	d2G4
Wiring method	Conduit terminal	Conduit terminal	Conduit terminal	Conduit terminal
Conduit entry	G1/2	G1/2	G1/2	G1/2
Manual operating	Non lock bush type	Non lock bush type	Non lock bush type	Manual button lock type
Operating temperature	-5 to 50 degrees C	-5 to 50 degrees C	-5 to 50 degrees C	-20 to 60 degrees C
Weight	0.3kg	0.46kg	0.85kg	1.24kg

Remark: The above are standard TOMOE-compatible solenoid valves. It is also possible to install solenoid valves other than those listed above such as a double solenoid or 3-port solenoid valve. For details, please consult us.

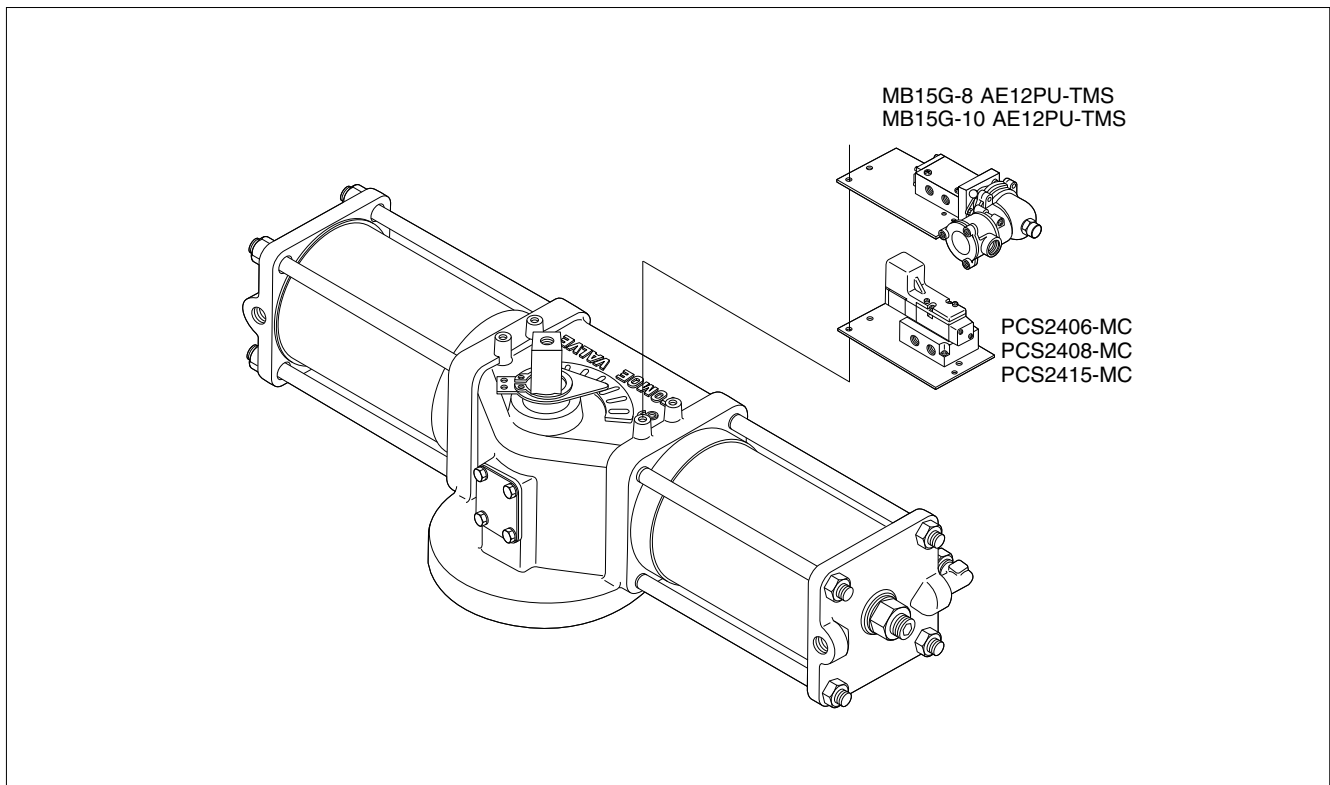

TGA Filter regulator (Pressure reducer with filter)

■ Purpose

Filter regulators are used to eliminate oil, water, and dust from the operating air in order to protect pneumatic accessories (solenoid valve and cylinder, etc.) and to keep operating pressure at an adequate and constant level (about 4 to 5 K).

■ Standard specifications

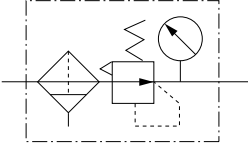
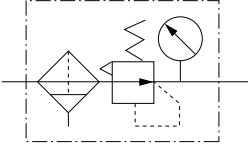
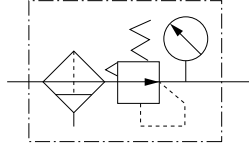
Type	AW20-02B-2-B-X490	AW30-03B-2-B-X490	AW40-04B-2-B
Manufacturer	SMC	SMC	SMC
JIS symbol			
Applicable cylinder type	TGA-100	TGA-125 to 180	TGA-200 to 250
Set pressure range	0.05 to 0.85MPa	0.05 to 0.85MPa	0.05 to 0.85MPa
Pressure gauge connection port	Rc1/4	Rc1/8	Rc1/4
Operating temperature	-5 to 60 degrees C	-5 to 60 degrees C	-5 to 60 degrees C
Air connection port size	Rc1/4	Rc3/8	Rc1/2
Filtration	5μm	5μm	5μm
Option	Auto drain, low and high temperatures	Auto drain, low and high temperatures	Auto drain, low and high temperatures
Weight	0.5kg	0.79kg	1.52kg

Remark: The above are standard TOMOE-compatible filter regulators. It is also possible to install filter regulators other than those listed above. For details, please consult us.

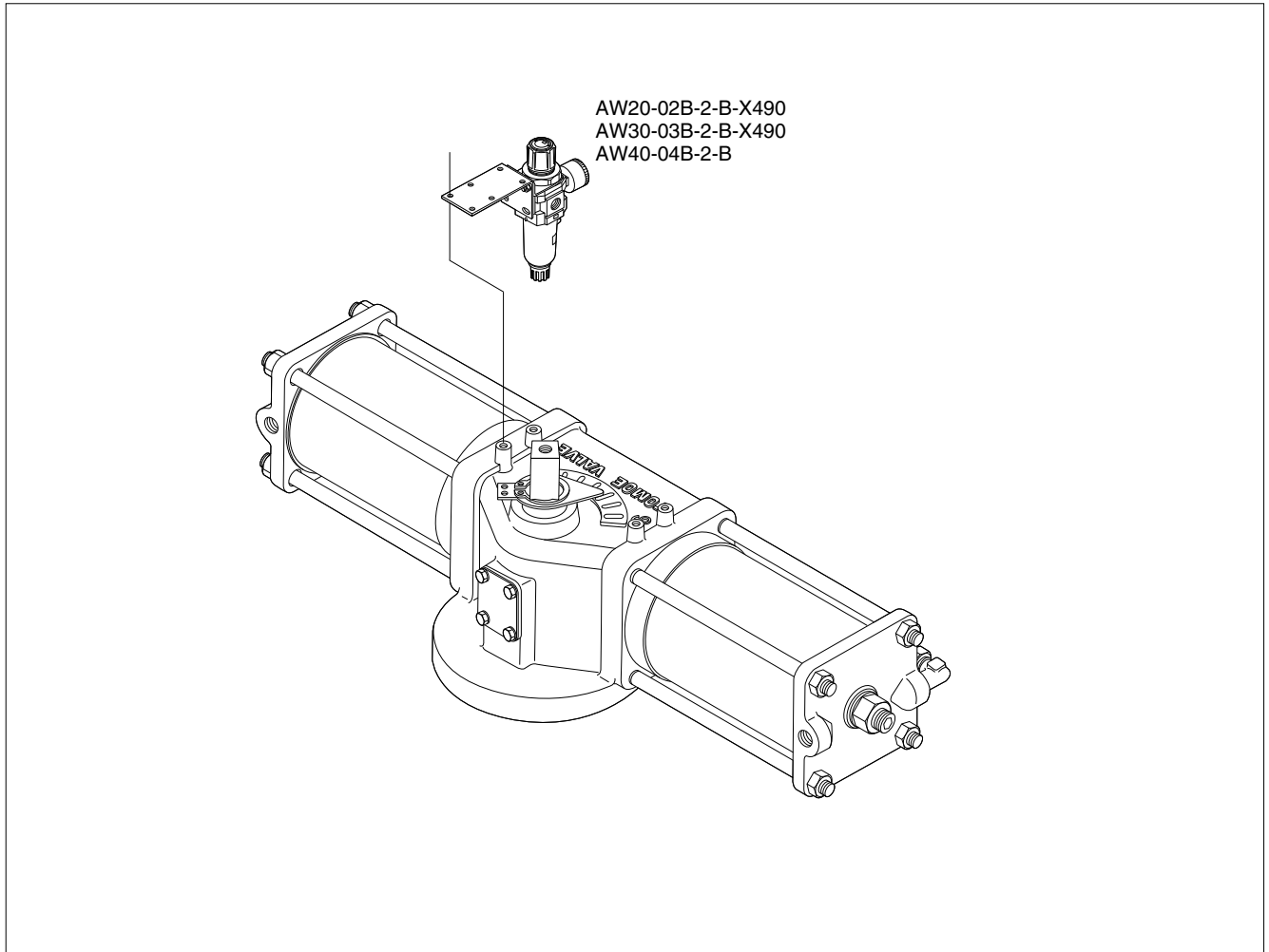

TGA Limit switches

■ Purpose

Limit switches are used to convert the valve position (full close, full open, half open) into electric signals for lamp indication at a remote location.

■ Standard specifications

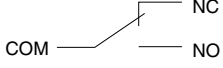
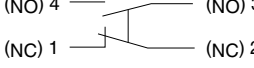
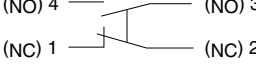
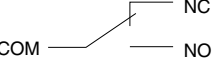
Type	TMS-BOX	1LS1-J WLCA2	1LX-7001	VCX-7003
Manufacturer	Tomoe	Azbil (1LS1-J) OMRON (WLCA2)	Azbil	Azbil
Circuit	Monopolar double-throw (1C, SPDT) X2 	Bipolar double interruption (1A1B, 2CKT-DB) 	Bipolar double interruption (1A1B, 2CKT-DB) 	Monopolar double-throw (1C, SPDT) X2 
Actuator	Hinge roller lever type	Roller lever type	Roller lever type	Adjustable roller lever type
Class of insulation	IP67 (Option: ExdII BT6)	IP67	IP67, Exde IIC T6	IP67, Exde IIC T6
Rated voltage (resistance load)	Standard	AC125V-10A AC250V-10A AC480V-10A DC125V-0.8A DC250V-0.4A	AC125V-5A AC250V-5A DC125V-0.8A DC250V-0.4A	AC250V-5A DC125V-0.8A DC250V-0.4A
	Micro load specifications			
Minimum applicable load (reference value)	DC30V 100mA	DC5V 1mA	DC24V 10mA	DC24V 10mA
Operating temperature	-10 to 80 degrees C	1LS1-J: -10 to 70 degrees C WLCA2: -10 to 80 degrees C	-10 to 60 degrees C	-10 to 60 degrees C
Conduit entry	2-G1/2	G1/2	G1/2	G3/4
Option	—	Heat, cold and corrosion resistant	Hydrogen anti-explosion (1LX5701)	Waterproof (VCL-5003)
Contacts	Switch detection with one (2 switches inside)	On or off detection with one Two for both on and off detection	On or off detection with one Two for both on and off detection	Switch detection with one (2 switches inside)
Weight	0.98kg	0.28kg	0.74kg	0.77kg

Remark: The above are standard TOMOE-compatible limit switches. It is also possible to install limit switches other than those listed above. For details, please consult us. Since the rated load of the TMS-BOX micro load specification is smaller than that of the standard specification, a failure may occur if a current exceeding the rating is applied.

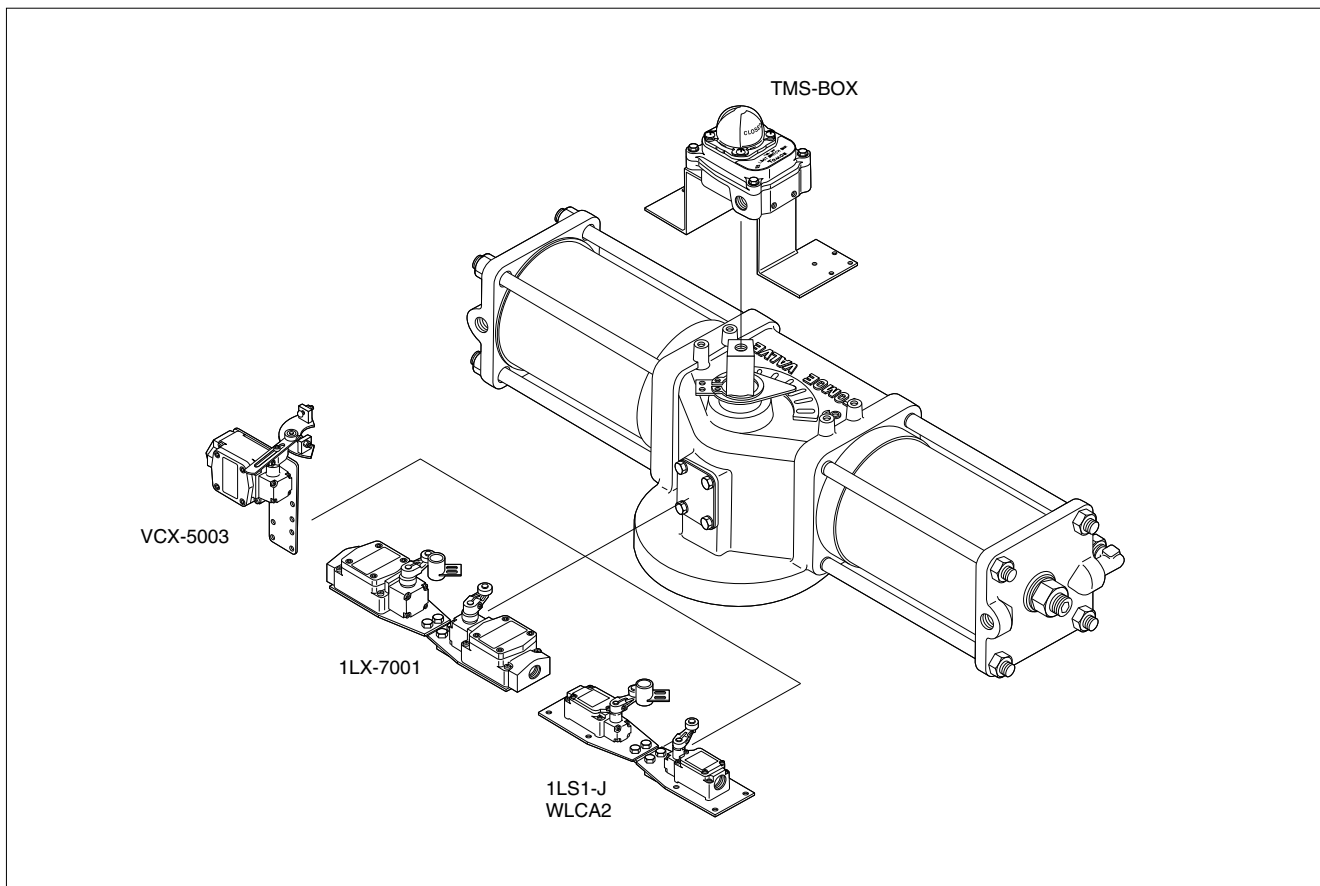

TGA Proximity Switches

■ Purpose

Proximity switches are used to convert the valve position (full close, full open, half open) into electric signals for lamp indication at a remote location.

■ Standard Specifications

Product	M18 shielded type (Can be embedded in metal.)	M18 non-shielded type (Cannot be embedded in metal.)	M30 shielded type (Can be embedded in metal.)
Type	E2E-X7D1-N	E2E-X14MD1	E2E-X10D1-N
Manufacturer	OMRON	OMRON	OMRON
With power source	DC 2-wire system	DC 2-wire system	DC 2-wire system
Motion mode	NO	NO	NO
Detecting distance	0 to 5.6mm	0 to 11.2mm	0 to 8mm
Object to be detected	Magnetic metal (stainless steel possible)	Magnetic metal (stainless steel possible)	Magnetic metal (stainless steel possible)
Power source voltage	DC12 to 24V	DC12 to 24V	DC12 to 24V
Current consumption	3 to 100mA	3 to 100mA	3 to 100mA
Class of insulation	IP67	IP67	IP67
Operating temperature	-25 to 70 degrees C	-25 to 70 degrees C	-25 to 70 degrees C
Connection	Cord draw type (2m)	Cord draw type (2m)	Cord draw type (2m)
Contacts	On or off detection with one Two for both on and off detection	On or off detection with one Two for both on and off detection	On or off detection with one Two for both on and off detection
Weight	0.13kg	0.13kg	0.18kg

Remark: The above are standard TOMOE-compatible proximity switches. It is also possible to install limit switches other than those listed above such as a DC 3-wire, AC 2-wire, AC/DC 2-wire or connector-type proximity switch. For details, please consult us.

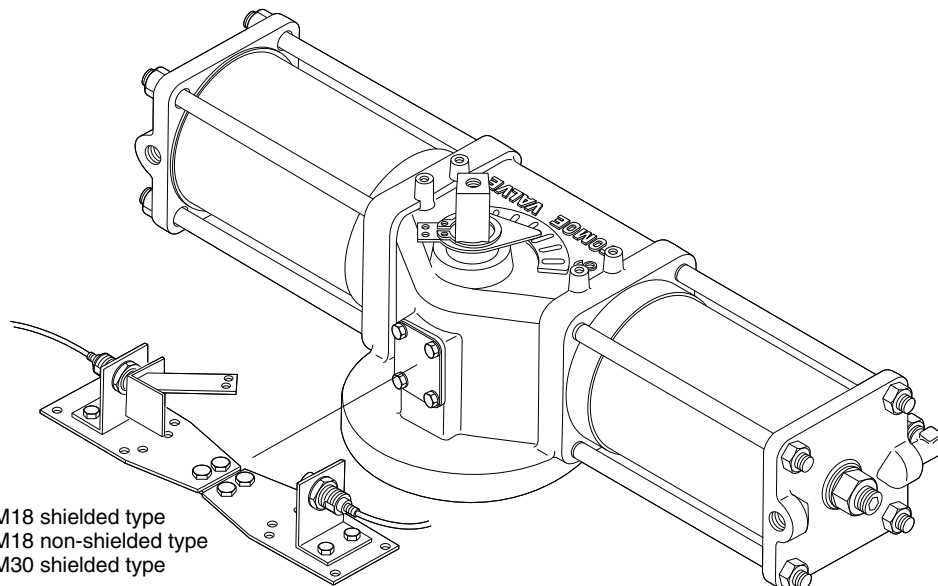

TGA Positioners

■ Purpose

A positioners are used for quick and accurate control of the valve opening angle with pneumatic signals or 4-20mA DC input signals from a control room or controller unit.

■ Standard specifications

	Electro-Pneumatic, analog	Electro-Pneumatic, analog	Electro-Pneumatic, digital (smart)	Pneumatic-Pneumatic
Type	TCE2000	TP8100	AVP300	IP5100
Manufacturer	Tomoe	Tomoe	Azbil	SMC
Input signal	4 to 20mA	4 to 20mA	4 to 20mA	0.02 to 0.1MPa
Resistance	250Ω (4 to 20mADC)	235±15Ω (4 to 20mADC)	300Ω (4 to 20mADC)	—
Supply air	0.14 to 0.7MPa	0.14 to 0.7MPa	0.14 to 0.7MPa	0.14 to 0.7MPa
Output flow rate	180L/min. or more (SUP=0.4MPa)	200L/min. or more (SUP=0.4MPa)	250L/min. or more (SUP=0.4MPa)	200L/min. or more (SUP=0.4MPa)
Air consumption	Within 11L/min. (SUP=0.4MPa)	Within 11L/min. (SUP=0.4MPa)	Within 10L/min. (SUP=0.4MPa)	Within 11L/min. (SUP=0.4MPa)
Operating temperature	-20 to 83 degrees C (Non explosion-proof) -20 to 60 degrees C (Explosion-proof type d2G4)	-20 to 8 degrees C (Non explosion-proof) -20 to 60 degrees C (Explosion-proof type d2G4)	-40 to 80 degrees C (Non explosion-proof) -20 to 60 degrees C (Explosion-proof type d2G4)	-20 to 80 degrees C
Class of insulation	IP65, ExdII BT6X	IP67, ExdII BT5	IP65 (option: Exd2CT6X)	—
Air connection port size	Rc1/4	Rc1/4	Rc1/4	Rc1/4
Conduit entry	2-G1/2	2-G1/2	2-G1/2	—
Sensitivity	Within 0.5%FS	Within 0.5%FS	Within 1%FS	Within 0.5%FS
Linearity	Within ±1.5%FS	Within ±2%FS	Within ±1%FS	Within ±2%FS
Hysterisis	Within 1%FS	Within 1%FS	Within 1%FS	Within 1%FS
Option	—	—	Analog signal (4 to 20 mA) output Any special opening setting Supports field bus.	—
Weight	2.3kg	2.6kg	2.8kg	1.2kg

Remark: The above are standard TOMOE-compatible positioners. It is also possible to install positioners other than those listed above. For details, please consult us.

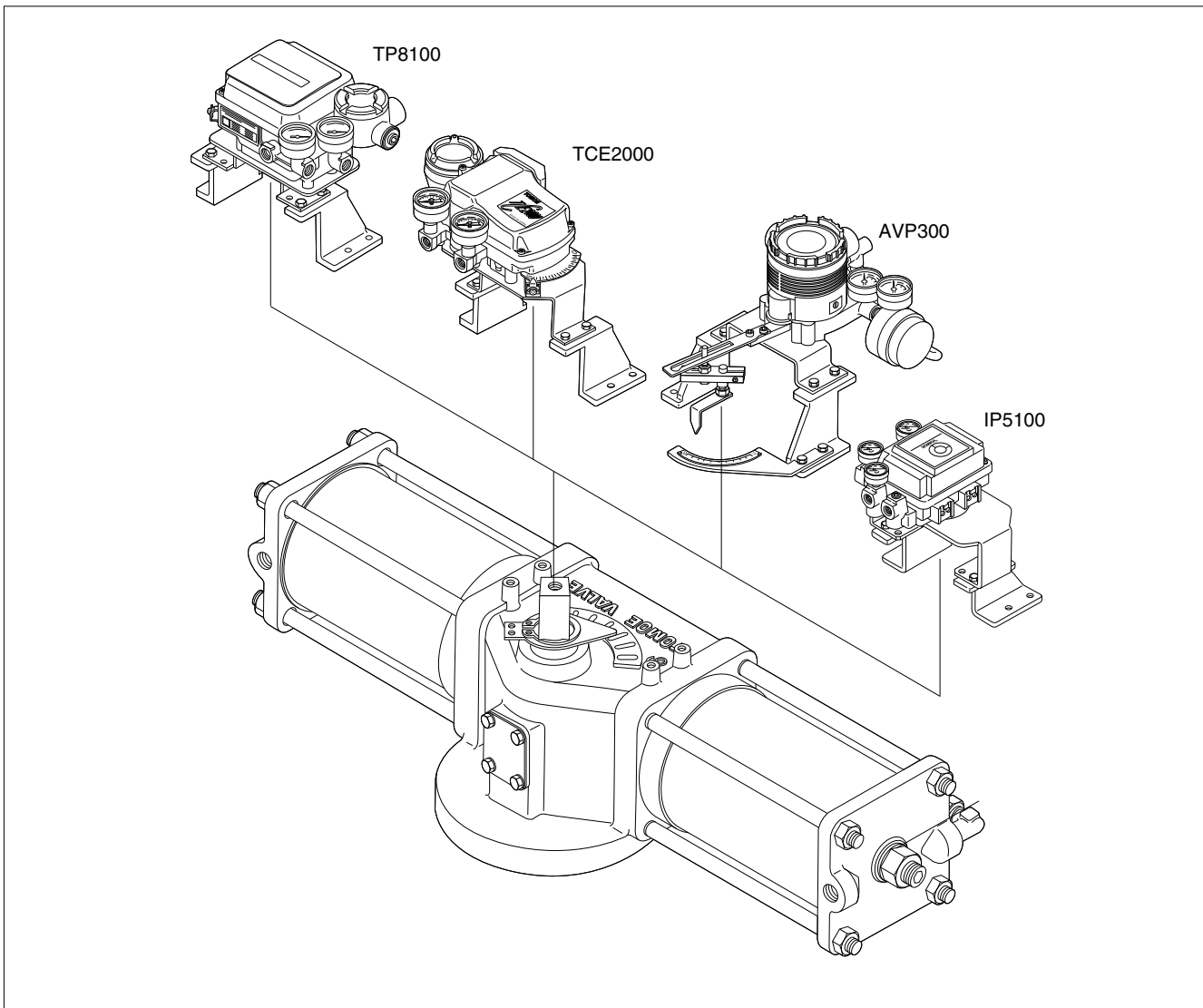

TGA Manual operation unit

■ Purpose

The operation unit is for manual operation of the pneumatic cylinder when air supply fails.

■ Standard specifications

	Function	Type	Applicable cylinder	Remarks
1	Manual gear unit	Worm gear	Double acting type TGA-100 to 250	(1) Be sure to open the bypass valve. (2) Refer to seal plate for operation when operate.

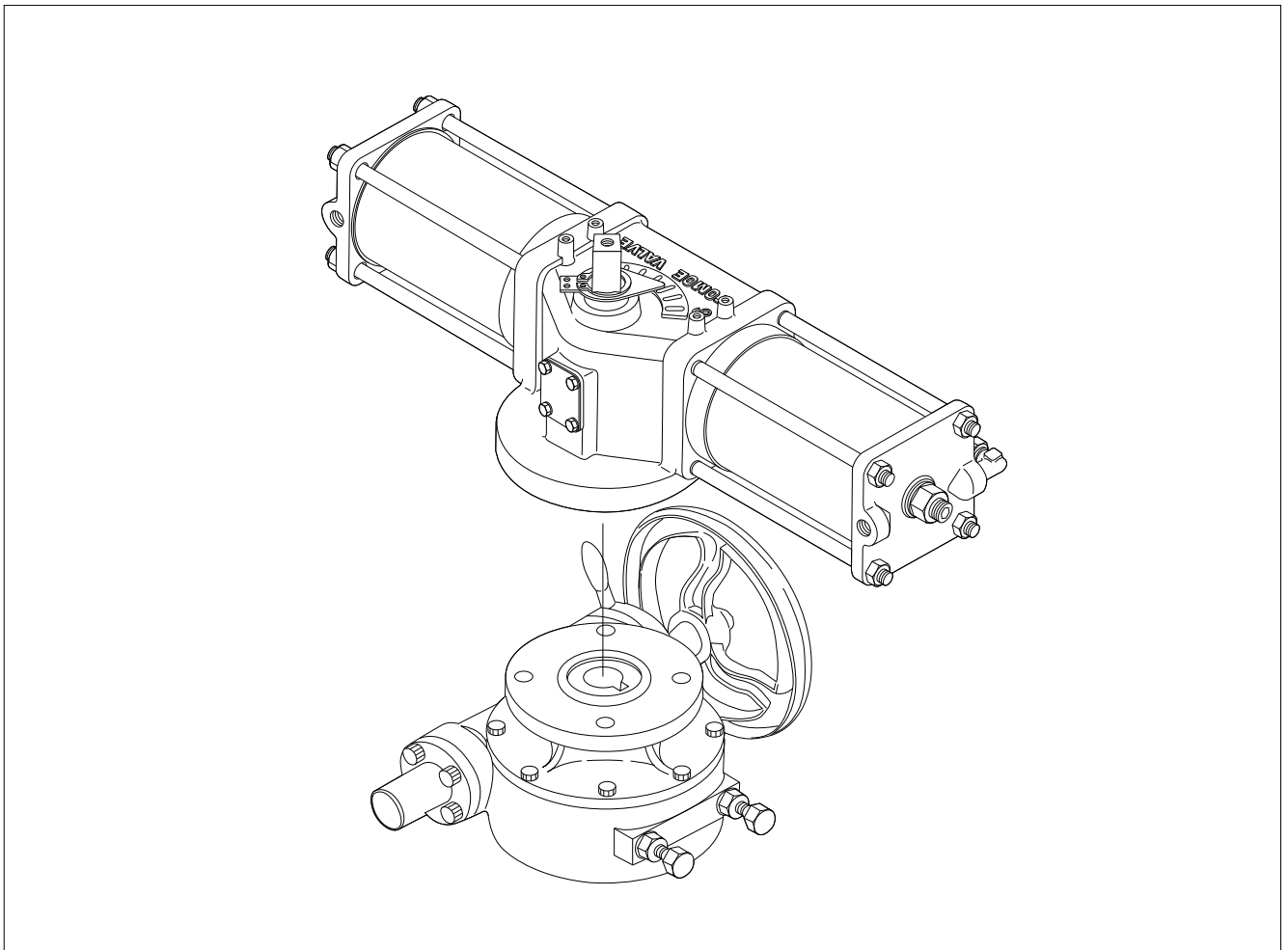

TGA Stroke adjuster

■ Purpose

The stroke adjuster sets the valve opening freely from the outside.

■ Standard specifications

Function	Type	Applicable cylinder	Remarks
Adjust screw	Side adjust screw	Double acting type TGA-100 to 250	(1) Loose protecting cover. (2) Tighten bolt to adjust the stroke angle. (3) Fasten protecting cover.

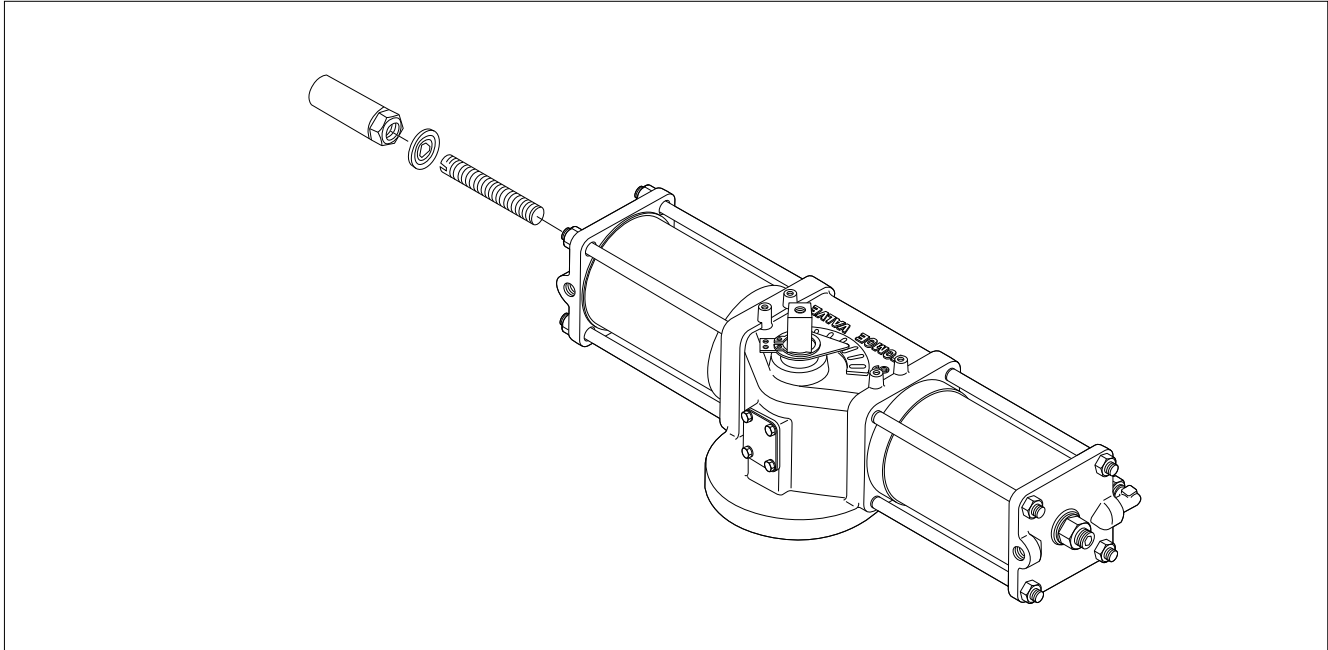

TGA Speed controllers

■ Purpose

Speed controller is used to adjust time of opening or closing.

■ Standard specifications

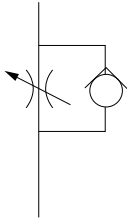
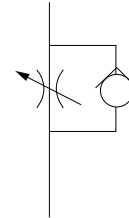
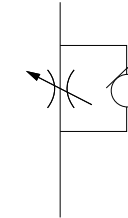
Type	AS2000-02	AS3000-03	AS4000-04
Manufacturer	SMC	SMC	SMC
JIS symbol			
Applicable cylinder type	TGA-100	TGA-125 to 180	TGA-200 to 250
Needle revolution	8 rotations.	8 rotations.	8 rotations.
Adjustable range	5 to 15 secs	5 to 15 secs	5 to 15 secs
Operating temperature	-5 to 60 degrees C	-5 to 60 degrees C	-5 to 60 degrees C
Air connection port size	Rc1/4	Rc3/8	Rc1/2
Attachement	Install to cylinder air connect port	Install to cylinder air connect port	Install to cylinder air connect port
Weight	0.12kg	0.13kg	0.21kg

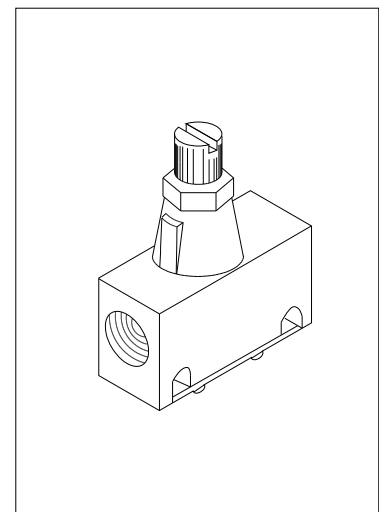



Remark: The above are standard TOMOE-compatible speed controllers. It is also possible to install speed controllers other than those listed above. For details, please consult us.

TGA Silencers

■ Purpose

Silencers eliminate noise at the exhaust ports on various kinds of pneumatic accessories.

■ Standard specifications

Type	AN20-02	AN30-03	AN40-04
Manufacturer	SMC	SMC	SMC
JIS symbol			
Effect of muffing	30dB (A)	30dB (A)	30dB (A)
Operating temperature	5 to 60 degrees C	5 to 60 degrees C	5 to 60 degrees C
Port size	Rc1/4	Rc3/8	Rc1/2
Attachment	Screw into exhaust port of solenoid valve.	Screw into exhaust port of solenoid valve.	Screw into exhaust port of solenoid valve.
Weight	0.02kg	0.03kg	0.04kg

Remark: The above are standard TOMOE-compatible silencers. It is also possible to install silencers other than those listed above. For details, please consult us.

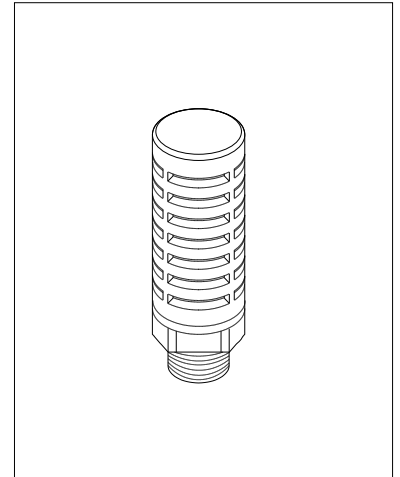

TGA Lock-up valves

■ Purpose

When air supply fails, the lock-up valve automatically stops the line until pressure is restored and keeps the operating unit of the cylinder at the stay-put position.

■ Standard specifications

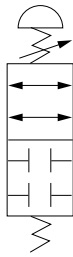
Type	IL211-02
Manufacturer	SMC
JIS symbol	
Effective sectional area	17mm ²
Operating temperature	-5 to 60 degrees C
Air connection port size	Rc1/4
Signal pressure connection port	Rc1/4
Weight	0.64kg

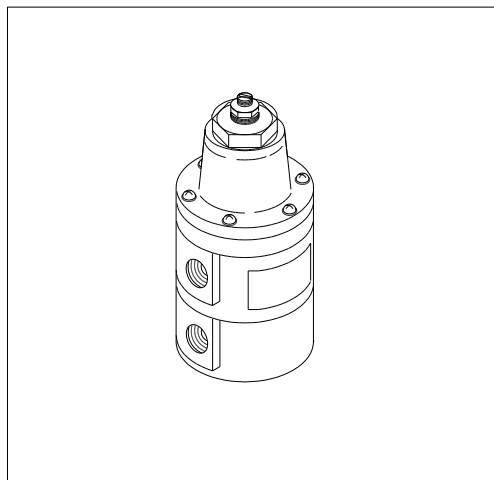

Remark: The above are standard TOMOE-compatible lock-up valves. It is also possible to install lock-up valves other than those listed above. For details, please consult us.

TGA Quick exhaust valve

■ Purpose

Quick exhaust valves act in the reverse way to a speed controller. The valve shortens the open/close operation time by improving the exhaust efficiency of the cylinder.

■ Standard specifications

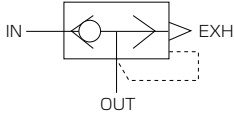
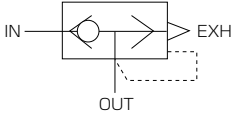
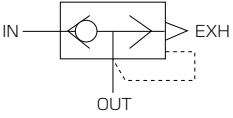
Type	AQ2000-02	AQ3000-03	AQ5000-04
Manufacturer	SMC	SMC	SMC
JIS symbol			
Operating temperature	-5 to 60 degrees C	-5 to 60 degrees C	-5 to 60 degrees C
Air connection port size	Rc1/4	Rc3/8	Rc1/2
Weight	0.1kg	0.21kg	0.69kg

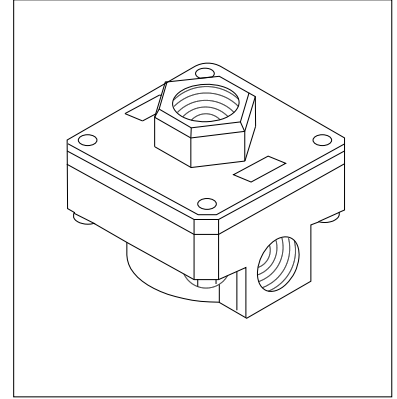

Remark: The above are standard TOMOE-compatible quick exhaust valves. It is also possible to install quick exhaust valves other than those listed above. For details, please consult us.

TGA Booster relay

■ Purpose

Booster relay is used to shorten time of opening or closing, and to improve switching in case pneumatic cylinder with poisoner. Quick exhaust valve is used together for on-off purpose.

■ Standard specifications

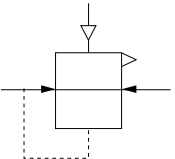
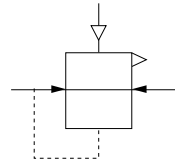
Type	IL100-02	IL100-03
Manufacturer	SMC	SMC
JIS symbol		
Output flow rate	600L/min (SUP=0.5MPa)	600L/min (SUP=0.5MPa)
Air consumption	Within 3L/min. (OUT=0.1MPa)	Within 3L/min. (OUT=0.1MPa)
Operating temperature	-5 to 60 degrees C	-5 to 60 degrees C
Repeatability	Within ±1%FS	Within ±1%FS
Hysteresis	Within 1%FS	Within 1%FS
Air connection port size	Rc1/4	Rc3/8
Signal pressure connection port	Rc1/4	Rc1/4
Weight	0.56kg	0.56kg

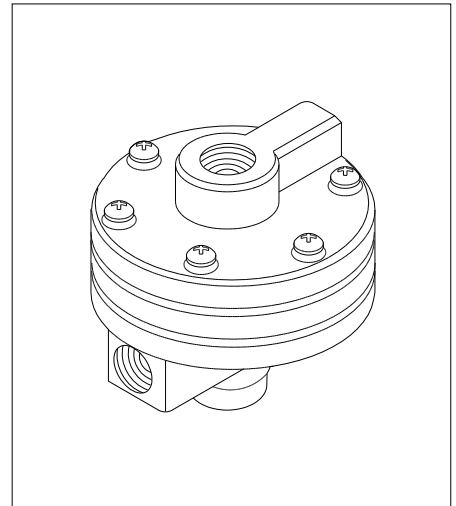

Remark: The above is a standard TOMOE-compatible booster relay.
It is also possible to install booster relays other than that listed above.
For details, please consult us.

Standard and semi-standard accessories and their use

Example of standard air circuit for on/off operation (double-acting type)

Shown below are standard circuits to open and close a butterfly valve driven by a double-acting air cylinder while transmitting electrical signals from a remote control room. Switching of the flow of operation air is performed by the solenoid valve, and detection of the open/close position of the valve is performed by a limit switch, with feedback of the electrical signals to the control room.

1 Butterfly valve opens when solenoid valve is energized.

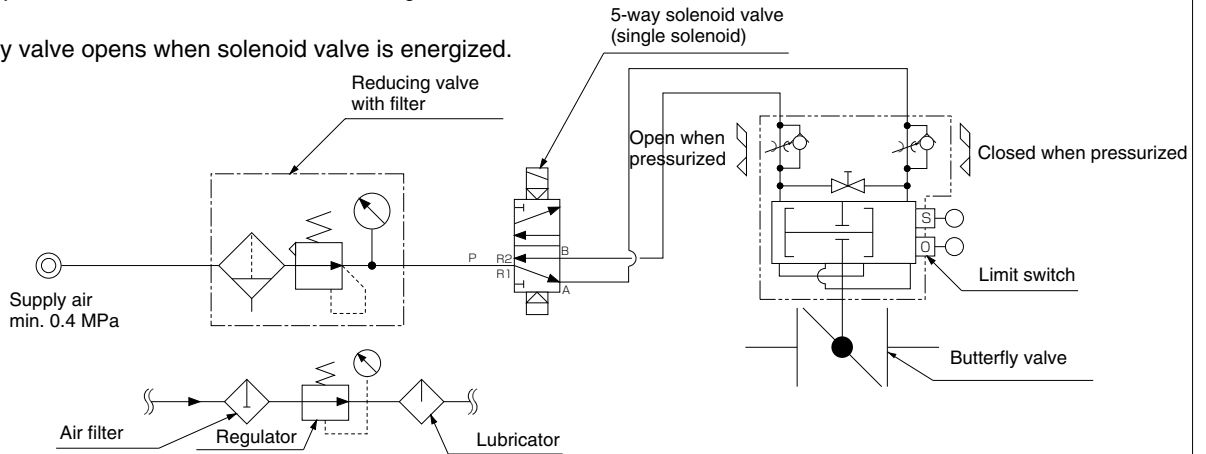

2 Butterfly valve closes when solenoid valve is energized.

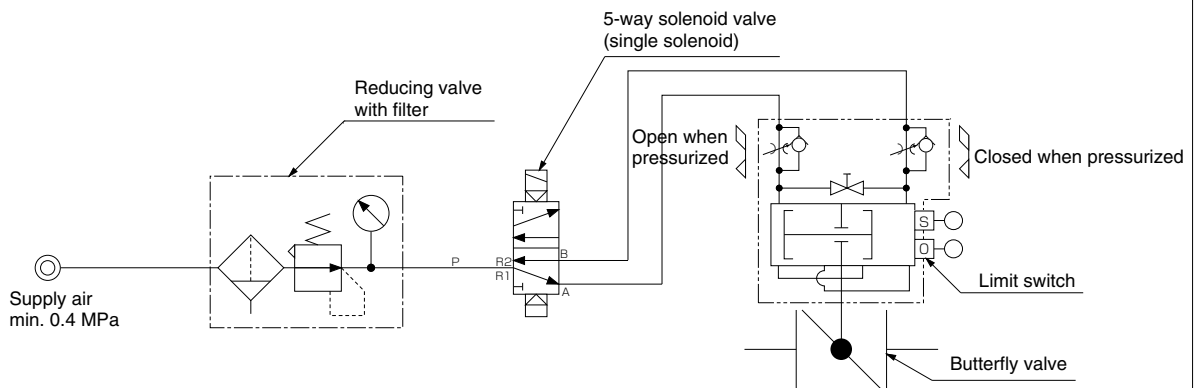

3 Butterfly valve closes when SOL.1 is energized. Butterfly valve opens when SOL.2 is energized.

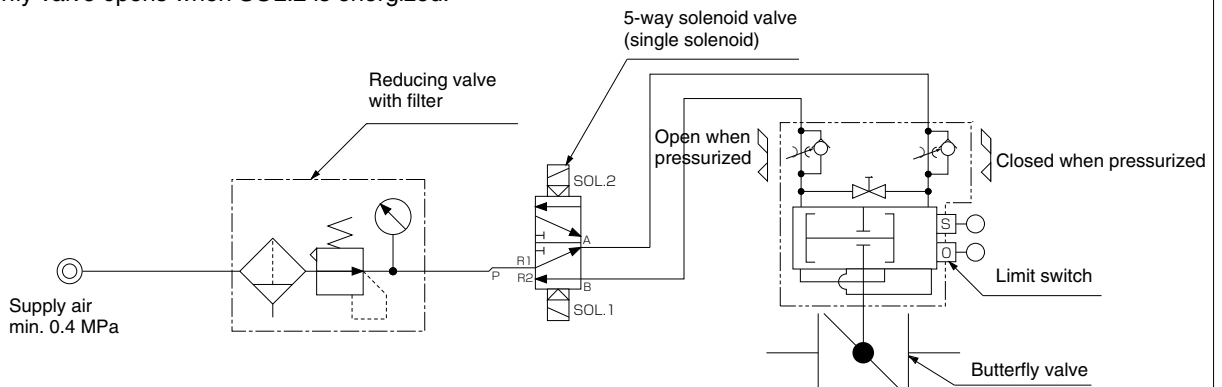

→Once SOL.1 is energized, the condition is maintained even after it is de-energized unless SOL.2 is energized.

Example of standard air circuit for control operation (double-acting type)

Shown below are examples of standard circuits in which a P/P or E/P positioner is attached to the butterfly valve driven by a double-acting pneumatic cylinder to give instruction signals from a remote control room to the positioner. This adjusts the valve opening exactly and quickly in proportion to the signals, and also detects the open/close position of the valve by a limit switch which sends feedback of the electrical signals to the control room.

4 Direct action

- Butterfly valve closes when signal increases.
- Butterfly valve opens when signal decreases.

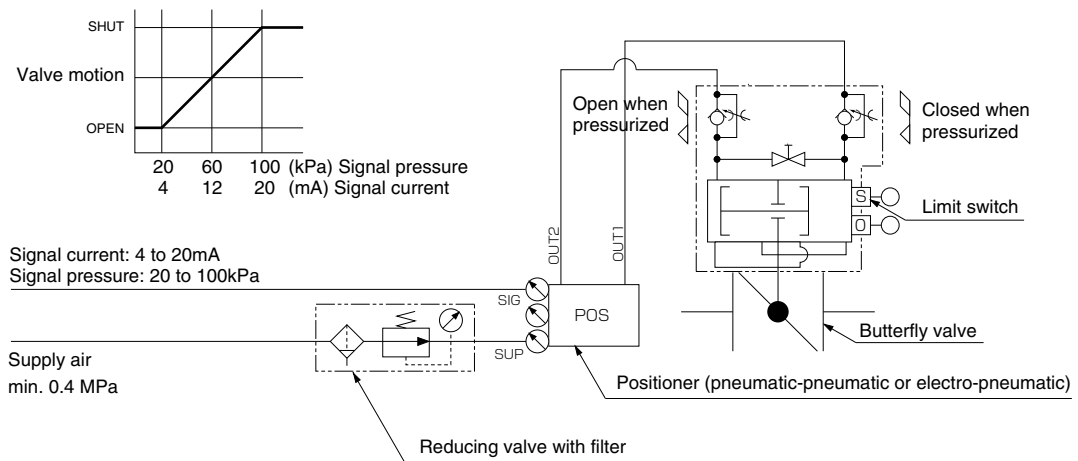

→The butterfly valve opens fully when the input signal goes off under a state of assured air supply.

5 Reverse action

- Butterfly valve opens when signal increases.
- Butterfly valve closes when signal decreases.

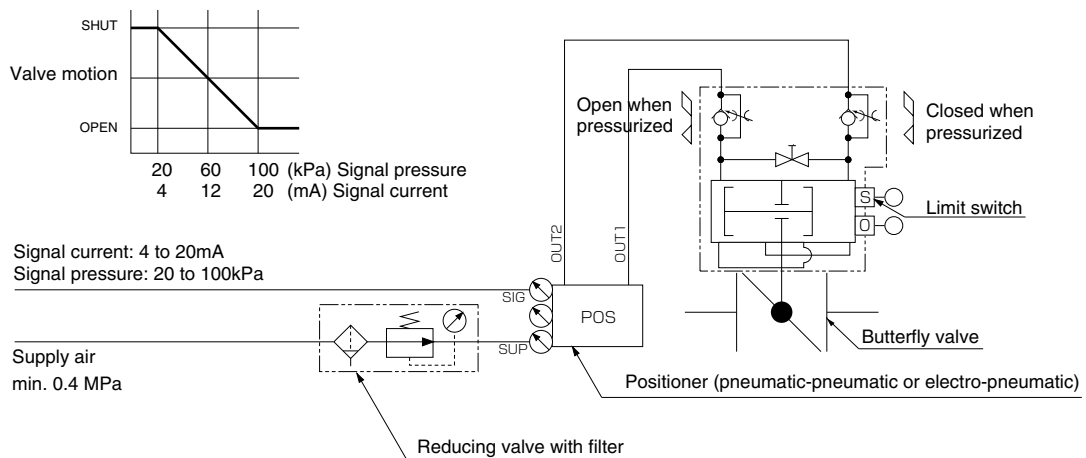

→The butterfly valve closes fully when input signal goes off under a state of assured air supply.