

Anti-Vibration Check Valve

MKT Series

(907T•908H)

INSTRUCTION MANUAL

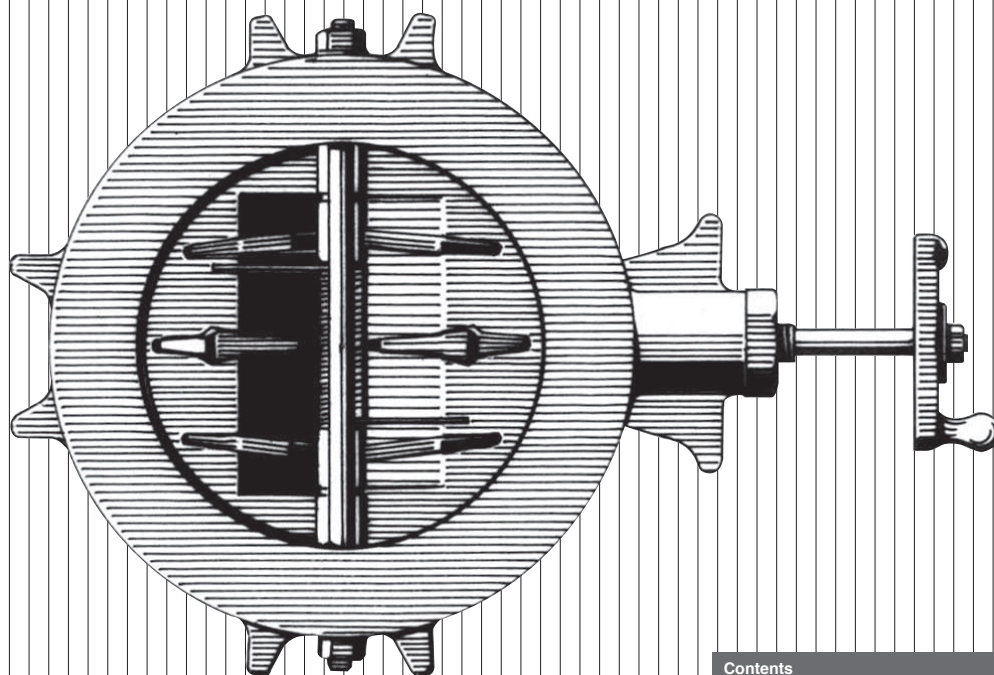

Contents	Page
MKT Series Standard Specifications	2
Expanded View	3
Precaution for Use	4
Installation Procedure	10
Precautions for Safe Handling After Installation	12
Inspection and Countermeasures	12
Disassembly/Assembly Procedures	13
Pressure Loss, Flow Characteristics	18
Valve Specifications and Standards for Selecting Springs	19
Available Pipe List	20
Cracking Pressure (Opening Pressure)	21
Quantity and Dimensions of Piping Bolts	21
Before Placing an Order	22

FOR YOUR SAFETY IN USE

The following instructions should always be followed.

Thank you for purchasing our products.

For proper use of our products over long periods of time, please read this instruction manual thoroughly before use, and use the products properly in accordance with its contents.

The instructions in this document are to promote the correct use of the check valve MKT series (hereinafter "this product") and to help prevent injury or damage.

■ The levels of danger and damage when these cautions are neglected and the product is used incorrectly are classified and described below.



Warning

This sign indicates "possibility of death or serious injury".



Caution

This sign indicates "possibility of injury to personnel or physical damage to property only".

■ The types of advisories to be observed are classified and indicated with the symbols below (The following symbols are examples.)



This symbol indicates items that "you must not do".



This symbol indicates items "you must do".

■ Introduction

- Be sure to read this instruction manual before transportation, storage, piping and installation, operation, maintenance and inspection.
- This instruction manual does not describe all the assumed conditions concerning transportation, storage, installation, operation, maintenance and inspection of this product. If there are any questions, please contact our sales representative.
- Reference values and limit values for operation, maintenance and inspection, which are specified in this instruction manual, have been determined in consideration of maintenance management of this product. This product should be used within the range of the reference values and the limit values.
- Be sure to store this instruction manual in a readily accessible place for future reference after installation and when operation starts.
If a staff member in charge is changed, information concerning the storage place of this document and operation should be given to the member of staff taking over responsibility.
- If dents or scratches are caused by an impact, etc., for safety's sake you should stop using and replace the product.
- The contents of this instruction manual are subject to change without notice.

MKT Series Standard Specifications

		907T	908H
Valve structure		Wafer-type double-plate check valve	
Valve nominal diameter		50, 65, 80, 100, 125, 150, 200, 250, 300, 350, 400 mm *1	50, 65, 80, 100, 125, 150, 200, 250, 300 mm
Valve type		Check valve with bypass	
Applicable flange standard		JIS 10K, 16K, 20K ASME B16.5 Class125/150	
Face-to-face dimensions		JV8-1 (stainless steel valves, wafer-type check valves), SAS358	
Max. working pressure		2.0MPa	
Allowed flow velocity		0.5 m/s to 10 m/s (Max. 12 m/s)	
Allowable valve seat leakage standard		Tight shut	
Test pressure	Pressure resistance of body	3.0MPa	
	Valve seat leakage	High-pressure test 2.2 MPa (hydraulic)	
Working temperature range (without freezing)		NBR seat : 0 to 60°C EPDM seat : 0 to 100°C	
Standard materials	Main body *2	A536 Gr.65-45-12 (ductile cast iron)	A351 CF8 (equivalent to SCS13)
	Plate	A351 CF8 (stainless cast steel)	
	Pin	304 stainless steel	
	Spring	304 stainless steel	
	Seat *3	NBR, EPDM	
Pipe gasket		Required (please purchase a commercially available gasket that satisfies the flange standards)	
Coating		907T = Resin baked finish (Tomoe Green) 908H = No coating	

*1. 250A and 300A types include rubber sleeves. (Compared to the types without rubber sleeves, loss of pressure increases by approx. 8%.)
350mm & 400mm do not include bypass as a rule, and are made to order. Please contact our sales team.

*2. The rubber seat is vulcanized to the valve body valve seat surface.

*3. With fluid containing chlorine, the seat ring may deteriorate earlier than expected, depending on the concentration and temperature conditions.
Please contact our sales team for details.

* Never use an EPDM rubber seat if the valve is being used for oil or for a fluid containing even a trace of oil.

When a chemical agent containing calcium is charged to protect the piping, EPDM seat ring is recommended.

Incorrect selection of the valve specifications according to the fluid conditions and installation conditions may cause vibration noise during operation.
Refer to "MKT Valve Specifications and Standards for Selecting Springs" and "Handling Precautions".

Expanded View

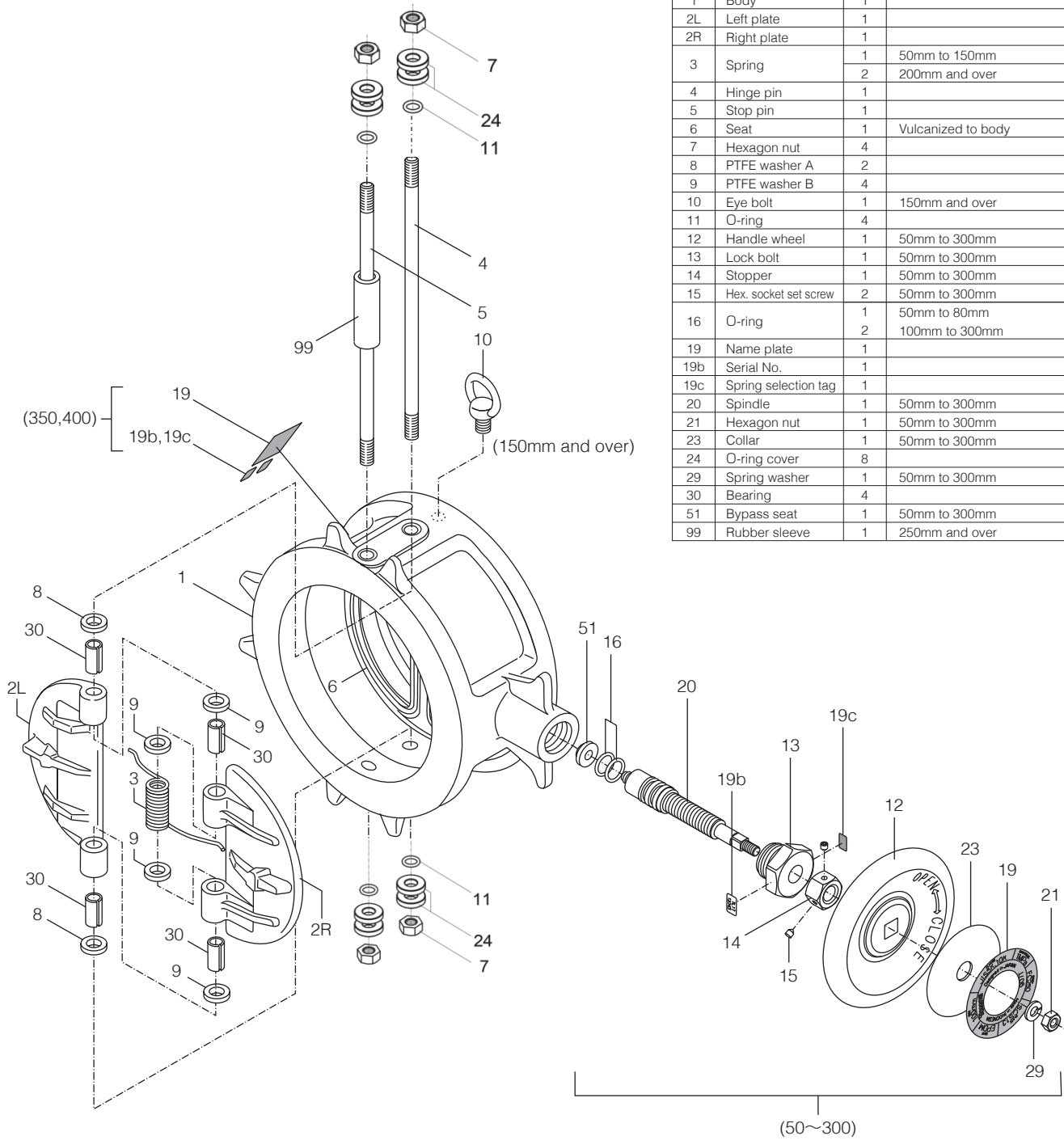

907T/908H Parts list

No.	Description	Q'ty	Remarks
1	Body	1	
2L	Left plate	1	
2R	Right plate	1	
3	Spring	1	50mm to 150mm
		2	200mm and over
4	Hinge pin	1	
5	Stop pin	1	
6	Seat	1	Vulcanized to body
7	Hexagon nut	4	
8	PTFE washer A	2	
9	PTFE washer B	4	
10	Eye bolt	1	150mm and over
11	O-ring	4	
12	Handle wheel	1	50mm to 300mm
13	Lock bolt	1	50mm to 300mm
14	Stopper	1	50mm to 300mm
15	Hex. socket set screw	2	50mm to 300mm
16	O-ring	1	50mm to 80mm
		2	100mm to 300mm
19	Name plate	1	
19b	Serial No.	1	
19c	Spring selection tag	1	
20	Spindle	1	50mm to 300mm
21	Hexagon nut	1	50mm to 300mm
23	Collar	1	50mm to 300mm
24	O-ring cover	8	
29	Spring washer	1	50mm to 300mm
30	Bearing	4	
51	Bypass seat	1	50mm to 300mm
99	Rubber sleeve	1	250mm and over

Precaution for Use

Safety Measures



1. Handling of this product

- (1) This product should be assembled, operated, maintained, etc. by personnel who have read the instruction manual (hereinafter "this document") thoroughly and understood the contents well.
- (2) The work should be performed while wearing protective gear, such as a helmet, safety belt, protective glasses, working gloves and safety shoes, in accordance with laws and regulations, and safety provisions of business establishments.
- (3) Do not stand or place heavy objects on this product, as this may cause the product to be damaged, resulting in falling accidents.



2. Safety check

Never attempt to handle the machine and the system or remove the equipment before safety is ensured. Before removing the equipment, check the following items are in place to ensure safety.

- (1) Safety precautions for this product have been taken, such as prevention of falling of any parts or materials, or other accidental events.
- (2) The surface temperatures of this product, flanges, and pipes are at a safe level for surfaces to be touched.
- (3) The pressure in the piping is atmospheric pressure, and fluid has been drained from the interior of the piping.
- (4) Where the fluid flowing through the piping is toxic, flammable or corrosive, adequate safety measures have been taken.
- (5) Energy sources for the facilities related to this product, such as power supplies and air sources, have been shut off.
- (6) No fluid harmful to the human body is adhering to the product or to the peripheral piping.

Before restarting the unit, check the following items.

- (1) There is no failure or damage to this product visible, and no parts are missing.
- (2) No tools have been left on this product or on the pipes.
- (3) Nothing can hinder operation of this product.
- (4) A safe evacuation procedure is already in place in case of unexpected equipment movement, leakage, etc.



3. Water hammer

This product can be used with the purpose of preventing water hammer due to water level reduction, by closing the valve when the pump is stopped. However, water hammer may still occur, depending on installation conditions such as opening/closing operations of other valves and piping height from the ground.

Design should take into account prevention of water hammer.

Occurrence of water hammer may damage this product and the peripheral piping materials.



4. Cavitation

Design should take into account prevention of cavitation.

This product can be operated at a maximum fluid velocity of 10m/s. However, cavitation may occur when the product is used at a velocity of 10m/s or less. If abnormal noise or vibrations are generated by the product or peripheral piping during fully-open operation, cavitation may have occurred. If the product is used for long periods of time in this state, the product or piping materials may be damaged. Cavitation should therefore be prevented, by changing the flow rate, etc.

Transportation and Storage



Warning

1. Transportation and Transfer

- (1) Products with large mass (150 mm or more) should be transported using suitable equipment or machinery, not by manpower alone. See the catalog, product drawings, etc. issued by our company for details on the mass of this product. Qualified personnel should perform work with a forklift, crane or sling in accordance with laws and regulations, and safety provisions of business establishments. In addition, please observe the instructions in "Dropping and falling" below.
- (2) While transporting this product, be careful not to damage the coated surface. If the surface is damaged, repair the coated film. Leaving surface damage unrepaired may result in corrosion.
- (3) Use shipping containers for ocean transportation. If the product is not sealed within a shipping container, it will deteriorate from contact with salt-laden wind and spray.
- (4) Use a covered vehicle for inland transportation to avoid exposure to wind and rain. If an open vehicle is used, cover the product with a protective tarpaulin and secure against the effects of weather.
- (5) Do not throw the product and do not apply a heavy load.



Warning

2. Dropping and falling

- (1) When lifting or using a sling to hoist this product, pay thorough attention to safety. For example, check the mass well in advance, and use lifting machinery or equipment rated to be safe for the mass. Ensure that no personnel ever stand or walk under or close to a suspended load.
- (2) Lighting during transportation must be sufficient to ensure safe operation, including lighting related to scaffolding to ensure its safe use. The stability of piping must be ensured before any work takes place on it.
- (3) During unloading or transportation between warehouses, this product should be secured properly at all times to prevent it from falling and sustaining or causing damage.
- (4) Do not use the product's handle to suspend or hoist this product. The handle may break off or fail and the product may be damaged, which is very dangerous.
If the nominal diameter of this product is 150 mm or more, use the hanger ring on the MKT body for hook attachment when hoisting.

3. Packing state

- (1) If the nominal diameter of this product is 50 mm to 200 mm, the product is packed in a cardboard box. For other products, protective panels made of materials such as plywood are attached to the flange faces (pipe flange contact faces) of the body to protect the interior.
- (2) For the FCD body, rust prevention oil is applied thinly to the inner face of the body.
- (3) A name plate is attached. Nominal diameter, materials, etc. can be checked on the plate.



4. Unpacking

Unpack this product only when ready to connect it to the piping. Do not leave the product unpacked for long periods of time. This will prevent adherence of dust and harmful aerosols, and deterioration due to ozone or ultraviolet rays. Otherwise, degradation in performance of this product, contamination, discoloration or materials deterioration may occur.



5. Storage

Store this product as follows to prevent its degradation in performance, contamination, discoloration, and material deterioration. Store this product in a place with no dust or water droplets while avoiding direct sunlight, high temperatures and excessive humidity.

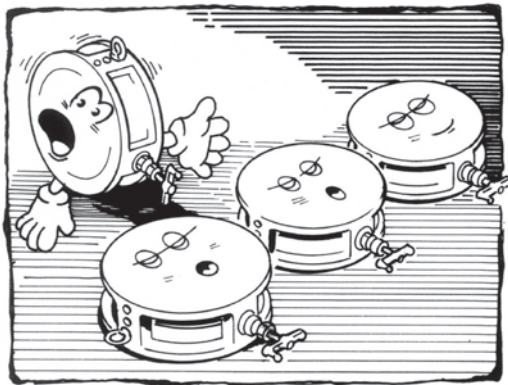

[Fig.-1]

- (1) Store this product in a cool and dark indoor area (ambient temperature: -10°C - 40°C, humidity: 70% or less) without removing the cardboard packaging or the protective material attached to the valve body.
[Fig.-1]
- (2) With cardboard packaging, high humidity may reduce the strength of the box and the packaging may deteriorate or separate, which may result in damage to the product. Be careful not to let the packaging become damp or wet.
- (3) Do not store this product in an atmosphere that contains corrosive gas. Otherwise, the parts may be subject to corrosion, resulting in an impairment of functions.
- (4) Do not drop or overturn this product or subject it to vibration, and do not apply a heavy load to the product during storage. Otherwise, functions may be impaired.
- (5) Do not stack more than one item when storing this product. A load collapse may occur, which could cause damage to personnel and/or the product. (Refer to Transportation and Storage Section 2: "Dropping and Falling".)
- (6) Individual parts of this product, such as the handle, axle shaft etc., are not designed to carry the weight of the valve. The products must be stored so that no load is applied to such parts. Otherwise, the handle, axle shaft, etc. may become deformed or fail.

Installation and Working Environment



Warning

1. Installation location and working environment

In installation locations, sufficient work space should be planned and provided for anticipated work and maintenance.

In certain installation locations or working environments there may be extra requirements, such as compliance with laws and regulations, as well as functional conformance to specifications. If there are any questions, please contact our sales team at the planning stage. These special installation environments may include:

- (1) Special working environments which are not specified in the specifications
- (2) Environments where failure of the product would be expected to cause substantial damage to human beings, assets, surroundings etc.

e.g.: Facilities covered by the High Pressure Gas Safety Act, facilities covered by the Industrial Safety and Health Act, Nuclear power related facilities, vehicles, medical facilities, etc.



Caution

2. Atmosphere of installation location

The following measures should be taken, depending on the atmosphere of the installation location for this product.

- (1) Locations which are exposed to salt-laden atmospheres, corrosive gases, chemical solutions, organic solvents, steam, salt water, etc. should be avoided.
- (2) If there is a possibility that this product may be exposed to direct radiant heat or chemicals, the product and its attachments should be protected with covers.
- (3) Do not submerge this product. If it is installed in a place that is regularly exposed to water, such as near a cooling tower, protect the product and its attachments with covers.



3. Temperature of installation location

Using this product out of the allowable working temperature range causes thermal degradation or hardening of seat rings and O-rings, faulty operation due to thermal expansion of parts or differential thermal contraction, etc.

- (1) The ambient temperature of the installation location should be within the ambient temperature range of 0°C to 60°C.
- (2) If this product is exposed to direct sunlight, ensure that the working temperature remains below the upper limit of the above ambient temperature range.
- (3) This product should be kept away from heat sources, and should be installed in a location whose temperature is within the specified ambient temperature range. Please note that siting the product near a motor, an engine, an air compressor, a boiler, etc. may cause conditions to exceed the specified ambient temperature range.



Caution

4. Vibration and shock at installation location

The following measures should be taken if vibration or shock are factors at the installation location of this product.

- (1) When this product is used in the following conditions, check for factors potentially causing vibration or shock, such as acceleration values, and consult our sales team.
 - 1) Locations where excessive vibration or shock is anticipated
 - 2) Locations where vibration or shock is exerted regularly or continuously
- (2) Mounting and connecting sections of this product should be secured to prevent loosening as a result of vibration or shock.
- (3) Anti-vibration measures should be taken to isolate or reduce vibration or shock to the machine. Piping should be secured with firm supports, and where necessary vibration isolation materials should be used.
- (4) Connections should be checked periodically for looseness or deformation. If there is any abnormality, the bolts should be re-tightened or the parts should be replaced. A bolt working loose may cause the product to fall or rotate suddenly in an unexpected direction.

Installation Precautions



1. Precautions before installation

- (1) The working pressure, fluid and temperature ranges of this product depend on the materials of the seat ring. Prior to connection to the piping, be sure to check the valve specifications with nameplates, catalog, drawings, etc.
- (2) Ensure the safety of scaffolding and lighting required for machinery operation and working at the installation location of this product.



2. Precautions at installation

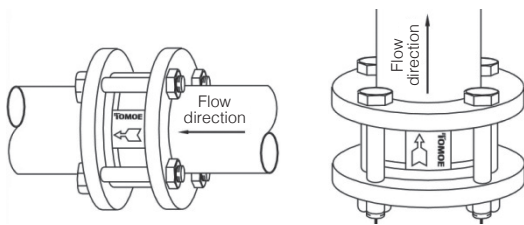

[Fig.-2]

When connecting this product to the piping, pay attention to the following points.

To ensure safety, if dents or scratches are caused by an impact, stop using the product and replace it.

- (1) When installing piping, ensure that the fluid flow direction matches the direction of the casting arrow indicated on the body of this product. [Fig.-2]
- (2) Prior to installation to the piping, clean piping components thoroughly to remove dust, shavings, cutting oil, waste material, etc. from the interior.
- (3) This product and pipes must not be subjected to extreme force or impact. If this product is deformed or damaged due to rough handling, leakage or faulty operation may occur.
- (4) When installing, do not stand on this product or apply undue pressure to force components into position.
- (5) When tightening piping bolts, pay attention to the following precaution.

Using an impact wrench

Please be careful when using a high-torque impact wrench for installation to the piping or retightening piping bolts on this product. Unless an appropriate impact wrench is used and it is employed correctly, there may be deformation or damage to the body, seat rings, pipe flanges (particularly, flanges made of resin and resin lining), piping bolts, etc. If you use an impact wrench, use one whose maximum torque is no more than the "Maximum Allowable Torque" value in the following table.

For flanges made of resin and resin lining, the torque should be equal to or less than the recommended torque in Table 2.

<Table 1> Maximum Allowable Torque for Metal Flanges (Nm)

Bolt Nominal Size	M12	M16	M20	M22	M24	M30	M36
Max. allowable value	64 or less	150 or less	300 or less	400 or less	640 or less	1280 or less	2200 or less

Note) Lubricant should be correctly applied to bolts.

<Table 2> Maximum Allowable Torque for Resin Flanges and Resin Lining Pipe (Nm)

Valve Nominal Diameter	Bolt Nominal Diameter	Recommended Torque
40 - 100mm	M16	40
125 - 200mm	M20	80
250 - 350mm	M22	100
400 - 500mm	M24	130
550 - 900mm	M30	250

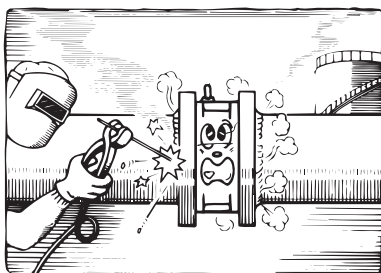

[Fig.-3]

- (6) Welding must never take place when the product is connected to the piping. Installation of the product must not take place immediately after the pipe flange has been welded, as the residual welding heat will cause thermal damage to the seat ring, resulting in adverse consequences. Before the valve is installed, ensure that the component temperature has reduced to ambient temperature, and weld spatters have been removed. [Fig.-3]

Installation Precautions(Continued)



(7) Be sure to use gaskets for piping. Do not use soft gaskets such as types made of soft rubber. This could cause faulty operation because the gasket could protrude to partially cover the interior face of the pipe, or could obstruct the bypass valve aperture. Select the correct gaskets referring to the following:

Gaskets

Be sure to attach gaskets to both sides.

Material : Non-asbestos, fluorine resin, hard rubber

Shape : Ring gasket (flat gasket), flat face gasket (with bolt hole), envelope gasket, spiral gasket, etc.

Dimension : Use commercial products conforming to the flange standards in use.

Note : Use a gasket with the correct inner diameter so that the bypass aperture is not restricted by the gasket, as shown in the figure on the right. Importantly, soft gaskets such as types made of rubber or fluorine resin must not be used, because the gasket could deform and obstruct the bypass aperture. Ensure the gasket inner diameter is correct and the gasket is not misaligned.



Plate Protruding Amount

Nominal Diameter		R	A	F
mm	inch			
50	2	29.0	30.0	0.0
65	2 1/2	36.3	36.0	0.0
80	3	43.2	40.5	0.0
100	4	53.3	38.0	8.4
125	5	66.0	47.5	11.0
150	6	78.9	53.5	17.5
200	8	104.2	72.0	25.7
250	10	129.8	83.5	37.7
300	12	154.5	110.0	35.0

(8) When this product is connected with other piping equipment, the plate protrudes to the downstream side. Therefore care must be taken that there is no interference with the plate. (Table to the left)

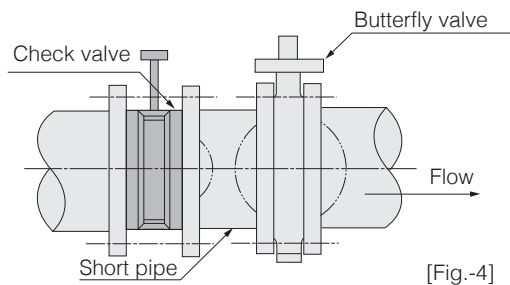

(9) When a butterfly valve is connected to this product, be sure to install a short pipe in between. The disc of the butterfly valve would otherwise contact this product when in use, which would cause faulty operation. When a butterfly valve is connected to this product using a short pipe, install piping so that the valve stem of the butterfly valve and the hinge pin of this product intersect at right angles. [Fig.-4]



(10) Align the center of this product accurately with the center of the flange. Operating this product with the centers misaligned may cause clogging of the bypass valve, leakage to the outside or vibration.

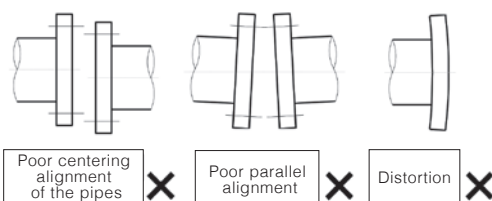

Do not use the connection of this product when correcting problems with the flange center, parallelism or distortion.

[Fig.-5]

(11) Align the primary side pipe accurately with the secondary side pipe and make sure that the pipes are parallel and there is no distortion. If the alignment is not accurate, external leakage or faulty operation may occur. [Fig.-5]

Installation Precautions (Continued)

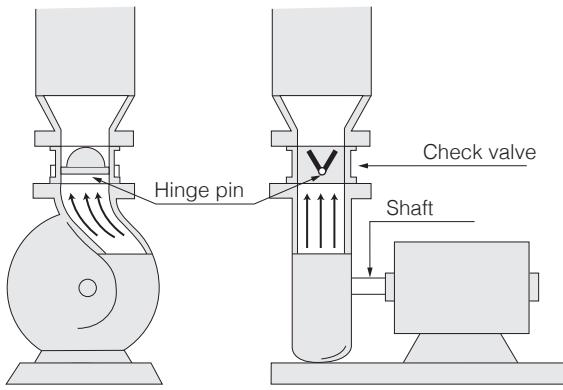

[Fig.-6]

(12) This product can be installed directly to a pump. In that case, follow the precautions below.

- ① When the product is installed at an uneven flow velocity distribution point, such as just after a centrifugal pump, install the product as shown in [Fig.-6] so that both plates of the check valve receive uniform flow.
- ② Use the product with an average pump outlet flow velocity of 10 m/s or less (for fresh water).
- ③ When the fluid is liquid and the flow velocity exceeds 5 m/s, this product may cause cavitation. To protect against this, install a valve or equipment on the downstream side in a position at least 2 x pipe diameter away from the product.
- ④ Be careful to avoid pressure loss at the check valve. (Refer to "Table of Pressure Loss, Flow Characteristics".)

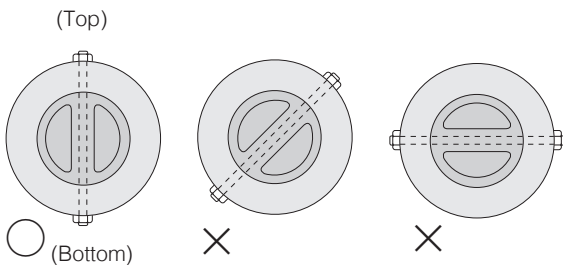

[Fig.-7]

(13) When installing this product to a pipe, the installation orientation should be as shown below.

- ① For horizontal installation, install the product so that the hinge pin is in an upright position. [Fig.-7]
- ② When installing the product to a bent pipe or at a pump outlet, install the product so that the flow has a uniform effect on the plates, as shown in [Fig.-8].

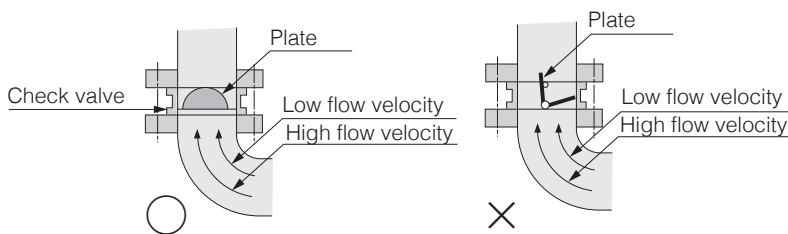

[Fig.-8]

(14) If fluid is liquid and the flow velocity exceeds 10 m/s, consult our sales team.

(15) When the product is used with a differential pressure of 0.04 MPa or less (water head pressure of 4 m or less), leakage may occur at the seating location.

(16) Ensure that no solvent adheres to the seat ring of this product. Perform the work while also being careful not to allow machine oil to adhere to EPDM. Adherence of oil may cause swelling of the EPDM seat ring, resulting in damage.



Installation Procedure

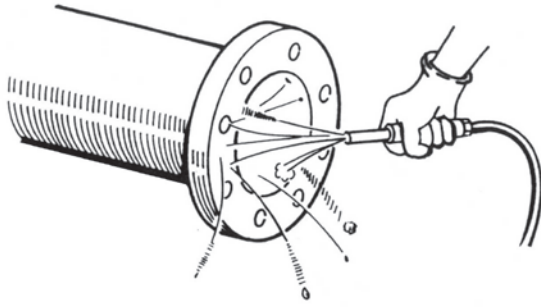

[Fig.-9]

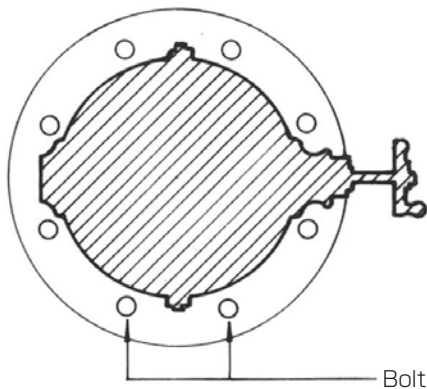

[Fig.-10]

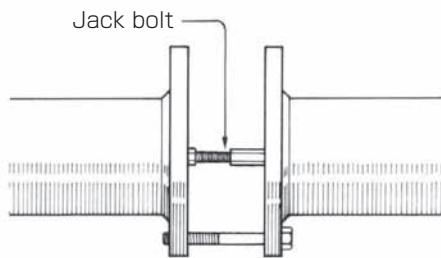

[Fig.-11]

(1) Clean the flange face that is going to make contact with the check valve by air purging. If there is rust or any other foreign substance sticking to the flange face, clean the face with a suitable cleaning fluid (alcohol, neutral detergent, etc.). [Fig.-9]

To clean the interior of a pipe, if possible, temporarily attach a short pipe with the same diameter as the check valve, and blast air through the interior of the pipe to remove foreign substances completely.

(2) After aligning the centers of the pipes, insert the piping bolts into the positions shown and secure the check valve to prevent it from dropping. [Fig.-10]

(3) Set the jack bolts in the positions shown, and widen the distance between the flanges. Push the flanges and ensure a clearance consisting of the check valve width 3 to 5 mm with each jack bolt. [Fig.-11]



(4) Insert the check valve so that its flange faces are not damaged, as shown. Note that if the check valve is pushed in between the pipes flanges forcibly at installation, the flange faces will be damaged, which will cause leakage. Be careful that the fluid flow direction matches the (casting) arrow direction on the check valve body. [Fig.-12]



(5) When the check valve is inserted completely, insert piping gaskets and then insert the piping bolts. [Fig.-12]

*Suspend the check valve with a crane, etc. when performing the work. When lifting the check valve, lift the eyebolt (nominal diameter: 150 mm or more) using a nylon sling.

[Fig.-12]

Piping bolt

(6) Install all the piping bolts, and remove the jack bolts. Then tighten the piping bolts with even force to avoid uneven tightening according to the following procedures until the piping flange face makes contact with the side of the body. If you use an impact wrench, be sure to read "Using an impact wrench" in "2. Precautions at installation" in this manual. [Fig.-13]

[Fig.-13]



Piping bolt tightening procedures

If there is no appropriate tightening procedure in place in business establishments, or there are no internal standards, tighten the bolts and nuts using the following procedures.

- (1) Clean the bolts and nuts and apply lubricant to them. (Do not use rusty or damaged bolts and nuts.)
- (2) Tighten the bolts and nuts by hand in any desired order.
- (3) Tighten the bolts and nuts in any desired order with approx. 20% of the specified tightening torque.
- (4) Tighten the bolts and nuts, alternate diagonally (refer to the right figure) with approx. 70% of the specified tightening torque.
- (5) Tighten the bolts and nuts, alternate diagonally, with approx. 100% of the specified tightening torque.
- (6) Tighten the bolts and nuts, alternate diagonally, with 100% of the specified tightening torque again.
- (7) Tighten the bolts and nuts clockwise with 100% of the specified tightening torque.

Bolts that have been tightened once may become loose due to compression of the gaskets when another bolt is tightened. Be sure to perform retightening in (6) and (7) repeatedly until the bolts and nuts are tightened evenly.

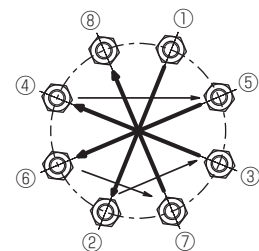

Example) Bolt tightening sequence

Precautions for Safe Handling After Installation

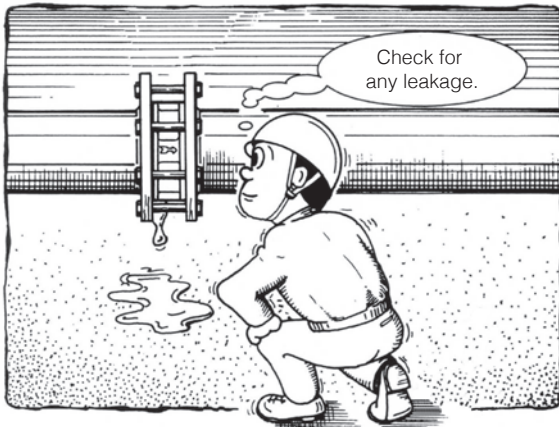

[Fig.-14]



After this product is connected to the piping, perform checks while paying attention to the following points. If the checks are not performed, serious accidents may occur, such as damage to the product.

- (1) Before starting operation, remove foreign substances from the interior and exterior of the pipes to ensure cleanliness.
- (2) Prior to operating, increase the internal pressure of the piping and check for leakage from the flanges, bypass valve, and nuts of the hinge pins/stop pins.
- (3) When performing a pressure test of the piping including this product, the pressure should be no more than 150% of the rated pressure for this product.
- (4) Never loosen the bolts, nuts or piping bolts of this product while water is flowing or when the fluid in the piping is under pressure. Fluid may otherwise escape under pressure as a jet, which would be dangerous.
- (5) If an external coating is applied to this product, be careful not to erase the warning indications, nameplate and flow direction indication arrow.

Inspection and Countermeasures

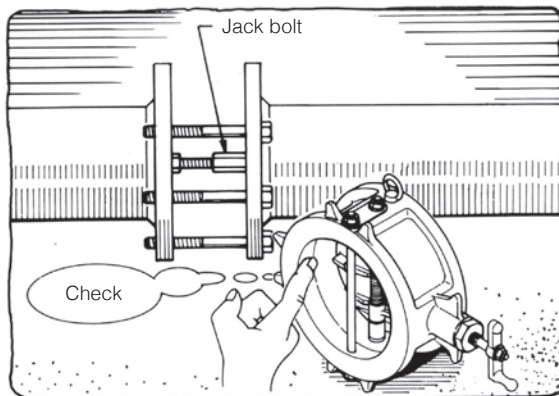

[Fig.-15]



- (1) Perform an annual check to detect any corrosion of the disc, check the seat ring for abrasion, and ensure smooth operation of the plates.
- (2) If valve seat leakage is observed when fluid circulation has stopped, check that the bypass valve is closed properly. Then check that the water head pressure head at the downstream side of this product is 4 m or more (on a vertical installation). If leakage does not stop even though the head pressure is correct, damage to the seat ring or malfunction of the plates should be assumed. Disconnect this product from the piping and check the seat ring and plate operation.
- (3) If leakage from the flanges is observed, reduce the pressure and then retighten the piping bolts and nuts. Refer to "Piping bolt tightening procedures" on page 11 for the tightening procedures. If leakage does not stop after retightening, reduce the internal pressure in the piping and drain water, and disconnect this product from the piping. Then check for any abnormality on the flange faces and piping flanges.
- (4) If leakage from the nut of the hinge pin/stop pin is observed, retighten the nut using the torque specified on page 17. If leakage does not stop after retightening, replace the seal washer.
- (5) If abnormal noise is heard during operation while water is circulating, there are the following possibilities: If the noise sounds like metallic contact, the cause may be fluttering of the plates due to unexpected drift. If the noise is continuous, the cause may be cavitation. Consider changing the installation position to reduce drift (refer to "Installation Precautions") or changing the flow rate.



Disassembly/Assembly Procedures

Disassembly procedures

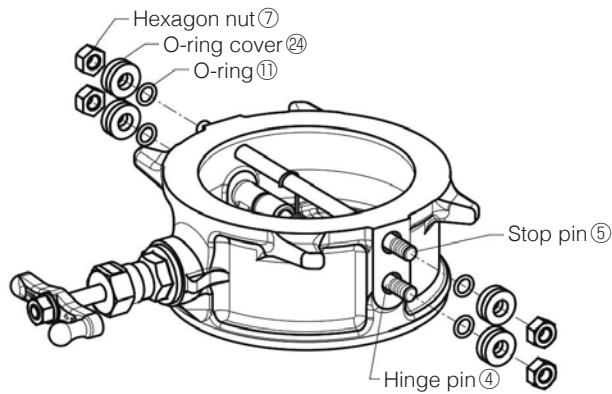

[Fig.-16]

- (1) Place the check valve on a horizontal place with its secondary side (the side where the pin can be seen) facing up. [Fig.-16]
- (2) Remove 4 hexagon nuts ⑦ from the side of the body with a spanner. Remove the O-ring cover ⑳ O-ring ㉑ from the hinge pin ④ and the stop pin ⑤. [Fig.-16]

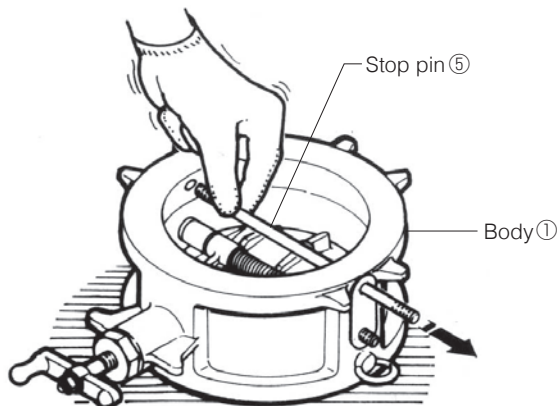

[Fig.-17]

[Table-2]

Nominal Diameter		Nut Size
mm	inch	mm
50	2	M6
65	2 1/2	M6
80	3	M8
100	4	M8
125	5	M8
150	6	M10
200	8	M12
250	10	M16
300	12	M16
350	14	M20
400	16	M20

- (3) Remove the stop pin ⑤ (upper pin) from the side of the body ①. [Fig.-17]
For products with a nominal diameter of 200 - 300 mm, one end of two springs ③ is held by the stop pin ⑤. Be very careful of rebound of the spring when removing the stop pin ⑤. [Fig.-18]

Nominal Diameter: 200 - 300 mm

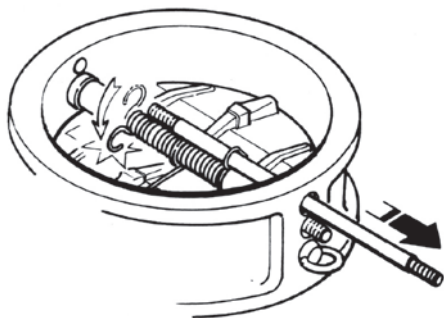

[Fig.-18]

- (4) Hold the spring ③ lightly by hand (2 pieces for a nominal diameter of 200 mm or more, and 1 piece for a nominal diameter of 150 mm or less). Then insert the previously removed stop pin ⑤ into the hole in the side of the body and push out the hinge pin ④ until half of the hinge pin ④ protrudes. [Fig.-19]

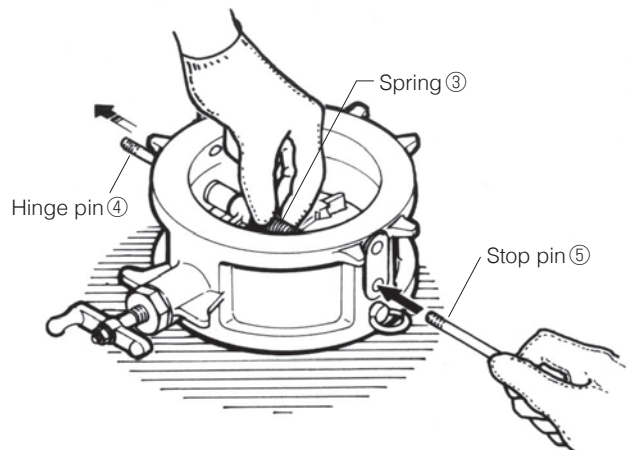

[Fig.-19]

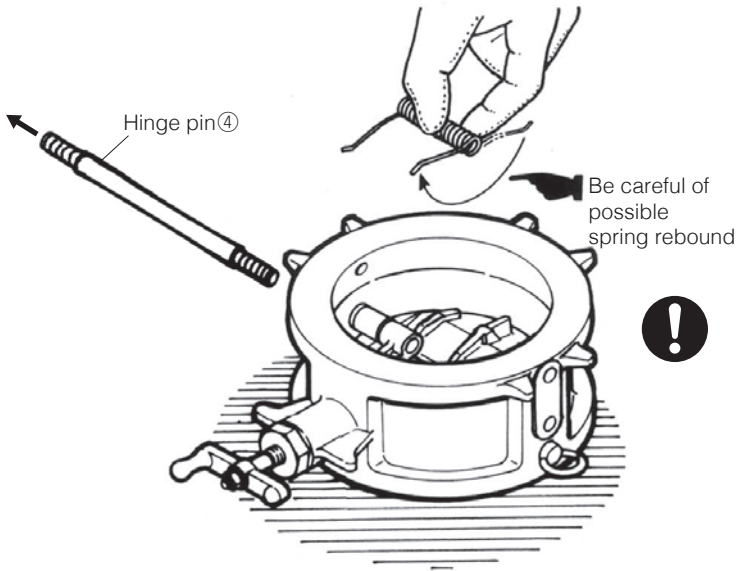

[Fig.-20]

(5) Pull out the hinge pin ④ and the stop pin ⑤ from the side of the body while holding the spring ③ by hand. It should be noted that the spring ③ will fly out if you remove the pins without holding the spring ③ by hand. Next, remove the spring ③ by slowly raising the hand holding the spring ③. [Fig.-20]



(6) Remove the plate ②. [Fig.-21]

*Note that scratches on the protrusion of the rubber seat and on the seat contact face of the plate can cause seat leakage.

(7) Remove 2 washers ⑧, 4 washers ⑨, and 4 bearings ⑩ from the plate hole. [Fig.-21]

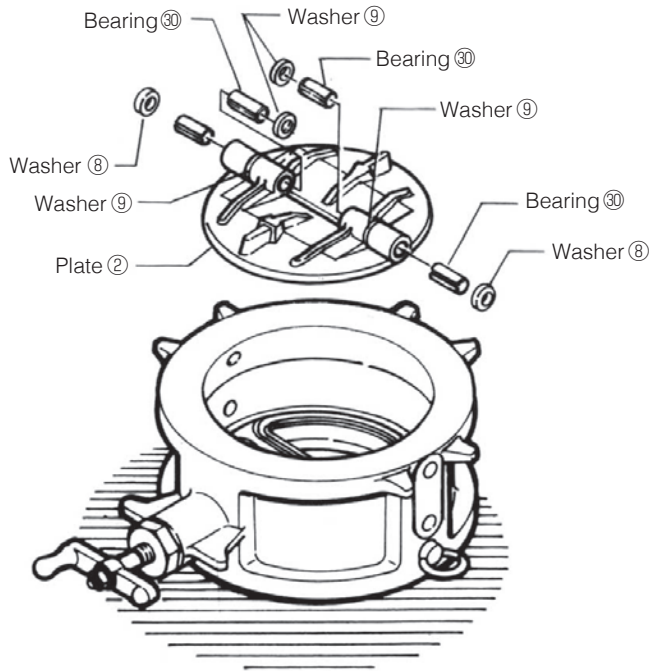

[Fig.-21]

(8) For disassembly of the bypass valve parts, loosen the handle ⑫ a few turns and remove the lock bolt ⑬. Then the bolt ⑬ and the spindle ⑭ can be removed.

Assembly procedures

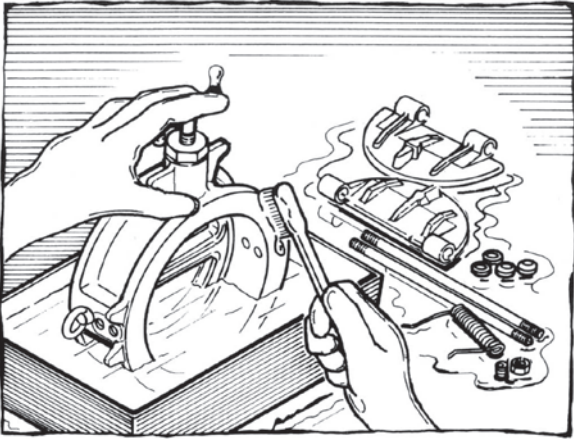

[Fig.-22]



When cleaning, be careful to avoid organic solvent adhering to the rubber seat. Organic solvent may cause deterioration of rubber or degradation of the rubber's adhesive strength.



If the rubber seat material is EPDM, do not allow oil or grease to make contact with the rubber. Adherence of oil may cause swelling of the seat ring, resulting in damage.

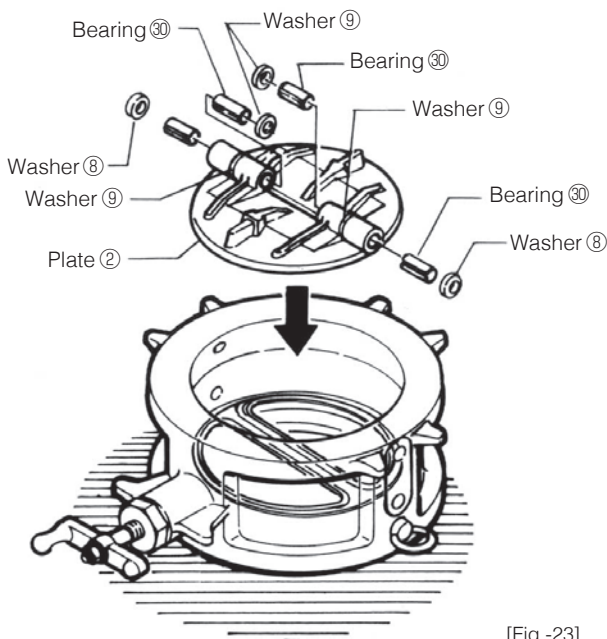

[Fig.-23]

- (1) Before reassembly, clean the parts thoroughly with a suitable cleaning fluid (alcohol, neutral detergent, etc.) and ensure that there is no damage or abnormality. In particular, conduct a thorough check on the projection of the seat and the seat contact face of the plate. If any damage or abnormality is found in any part, replacement is recommended.[Fig.-22]

- (2) Do not reuse parts which are not intended to be reusable. For washers ⑧ and ⑨, bearing ③①, seal washer ②⑥ and O-ring ①⑥ if there has been deterioration over time, even though the abrasion is minor, do not reuse these components but replace them with new parts. [Fig.-23] [Fig.-30]

- (3) Place the body ① on a horizontal surface with the same orientation as at disassembly. [Fig.-24]

- (4) Insert a bearing ③① into each shaft hole of the plate ②. [Fig.-23]

- (5) Place 2 plates ② into the original positions while aligning them to the center beam of the body. [Fig.-23]

- (6) Insert the washer ⑧ (spherical side should be body side) between the body ① and the plate ②, and pass the hinge pin ④ through the first plate hole from the lower hole on the side of the body. [Fig.-24]

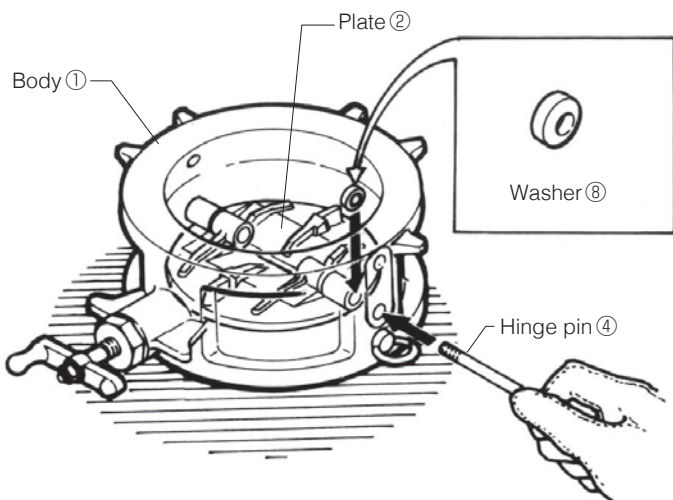

[Fig.-24]

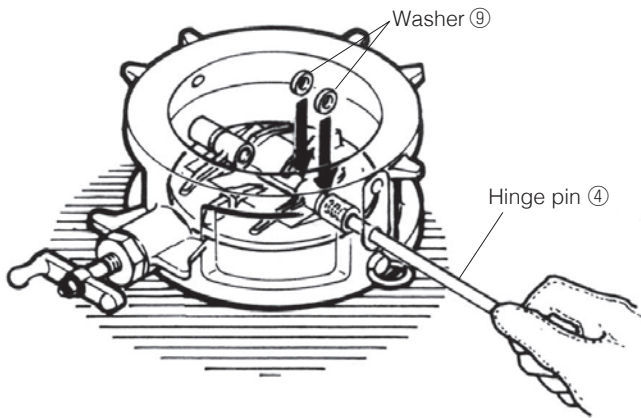

[Fig.-25]

(7) Insert the washers ⑨ (both sides are processed to be flat) between the plates and the inside of the plate, and pass the hinge pin ④ through the fluoro-resin washers ⑨. [Fig.-25]

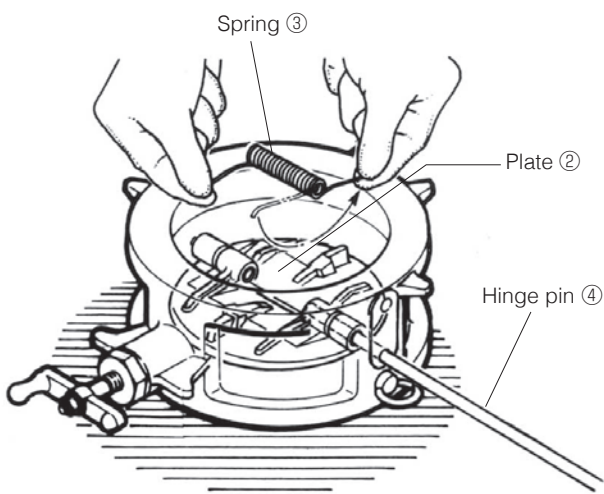

[Fig.-26]

(8) Place the spring ③ in the center of the plate ②, and pass the hinge pin ④ through the spring ③. Be careful of the installation orientation of the spring ③. (There are 2 springs, for 350 and 400 mm.) [Fig.-26]

(9) Insert the stop pin ⑤ into the lower hole on the back side of the body until the stop pin ⑤ goes through three washers ⑧ and ⑨ which are attached to the plate.

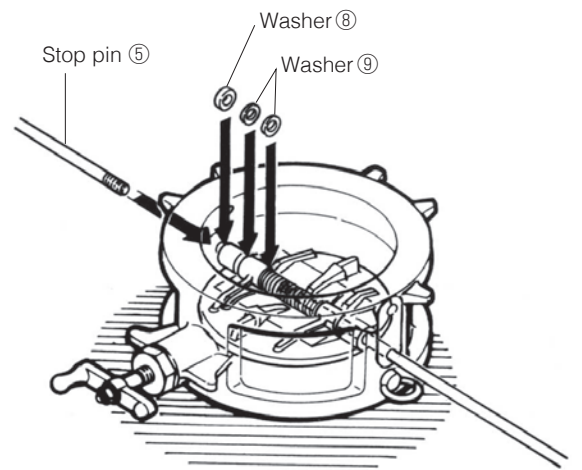

[Fig.-27]

(10) While holding the spring ③ lightly by hand from above, press in the hinge pin ④ to push out the stop pin ⑤. [Fig.-28]

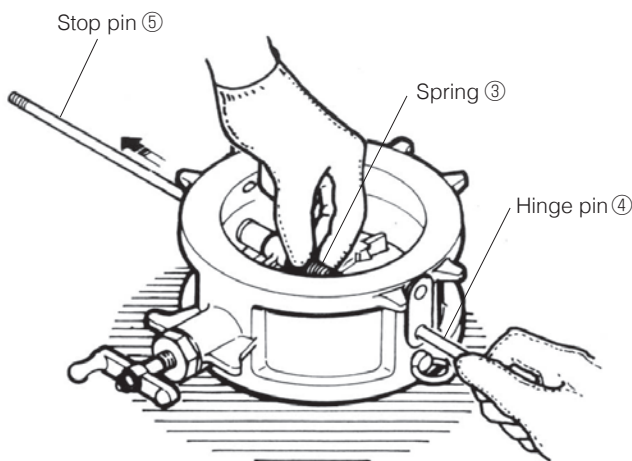

[Fig.-28]

(11) Insert the stop pin ⑤ into the upper hole on the side of the body and through the equivalent hole on the other side of the casing. [Fig.-29]

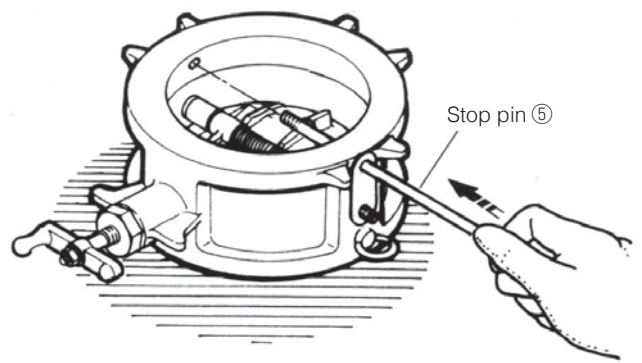

[Fig.-29]

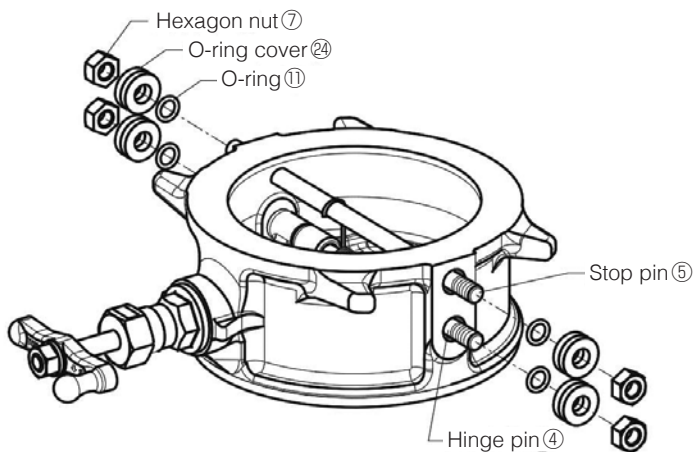

[Fig.-30]

(12) Secure the hinge pin ④ and the stop pin ⑤ to the body with the O-ring cover ②④ O-ring ①① and hexagon nuts ⑦ in 4 positions. [Table-3]

*Apply Loctite 243 (manufactured by Henkel Japan Ltd. Loctite Division) to the threads of the hinge pin ④ and the stop pin ⑤. Do not reuse the original O-ring ①①, but use a new one. [Fig.-30]

(13) Move plate ② by hand to check the plate is operating normally.

(14) For the bypass valve, remove the spindle ⑳ and the lock bolt ⑬, and clean them. Replace the O-ring ①⑥ with a new one and then reassemble. During assembly, apply silicon grease to the O-ring and the threads. The material of the O-ring should be the same rubber material of the seat.

[Table-3] Tightening Torque Values for Mounting Nuts of the Hinge Pin and the Stop Pin

Item \ Size	50,65mm	80~125mm	150mm	200,250mm	300mm	350,400mm
Nut Size	M6	M8	M10	M12	M16	M20
Nut Tightening Torque	3.4Nm	8.5Nm	24Nm	27Nm	68Nm	140Nm

Nominal Diameter: 200 - 300 mm

For products with a nominal diameter of 200 - 300 mm, install 2 washers ⑧, 4 washers ⑨ and 2 springs ③ with the correct orientation. Then insert the hinge pin ④ into the side of the body and assemble the washers and the springs. [Fig.-31]

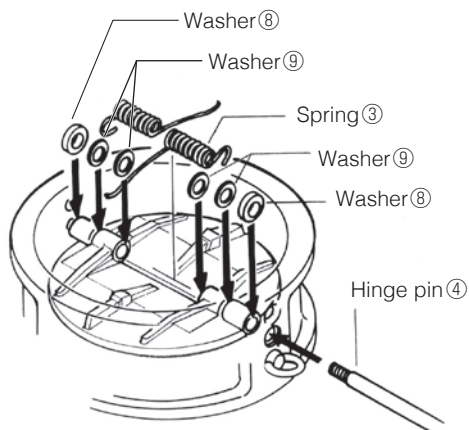

[Fig.-31]

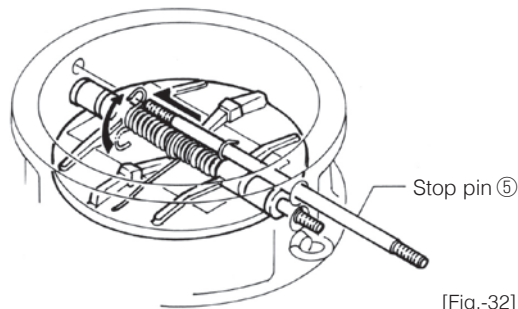

[Fig.-32]

Turn one end (the U-shape bent end) of the spring ③ to tension the spring. Then insert the stop pin ⑤ so that it holds the end of the spring ③ keeping the spring under tension. [Fig.-32]

Pressure Loss

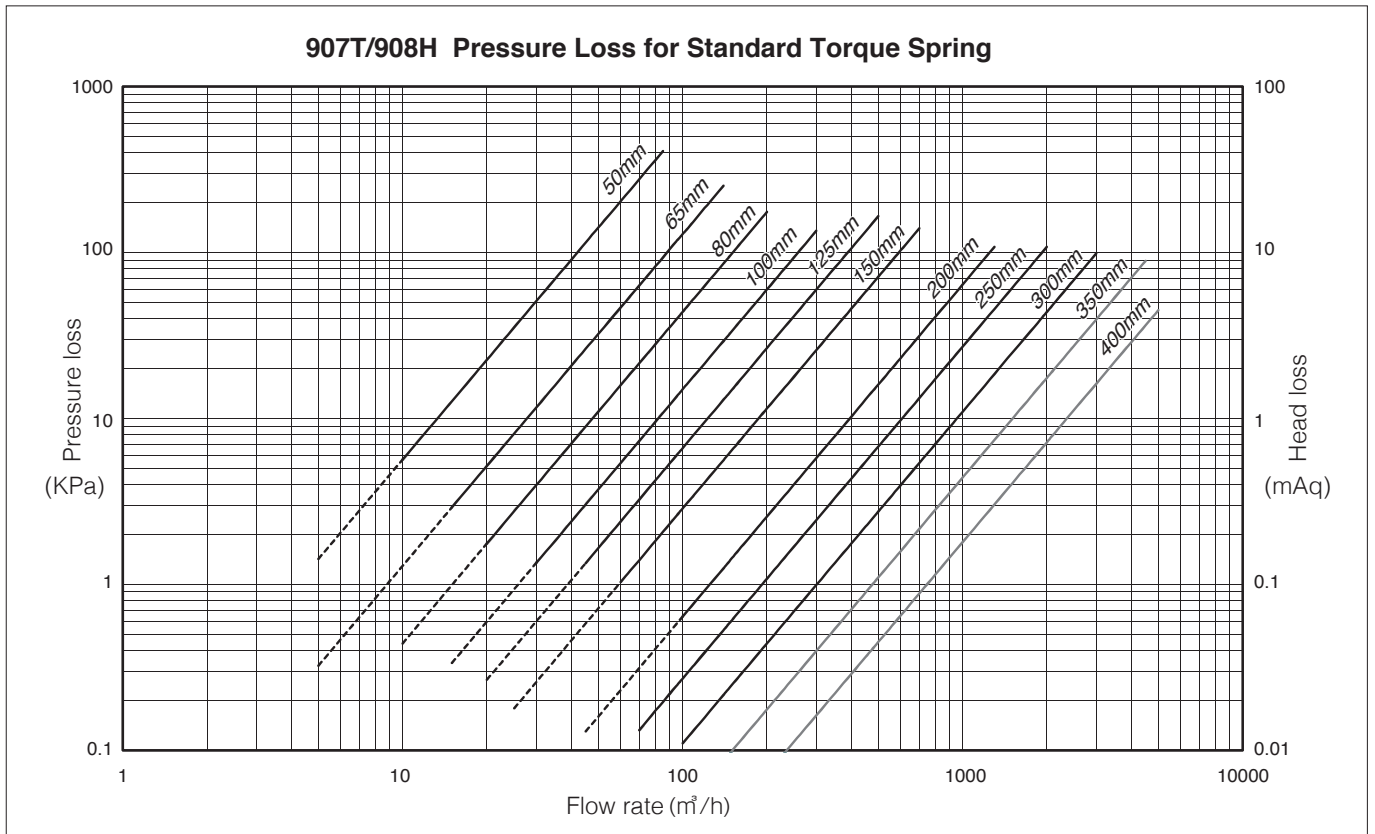

A solid line shows the pressure loss for a standard torque spring.

For a low-torque spring, the product can be used within the range from a dotted line to a solid line.

For a high-torque spring, please consult us.

Products with a nominal diameter of 350 or 400 mm are available only for 907T. They are made to order.

Valve Specifications and Standards for Selecting Springs

The following valve specifications are recommended so that the product can be used without chattering, according to the fluid type, installation environment, flow velocity (or pressure), and flow direction.

Table 1 Standards for Selecting Springs and Specifications

■ 2.0MPa 907T/908H

Flow Direction	Fluid	Condition	Min. differential pressure (MPa)	Size (mm)	Spring
Up flow 	Liquid (Clean water)	The valve should be installed directly after the following: - a reducer which is 3 sizes smaller than a valve - a curved pipe - a straight pipe	See Table A	50-400	Low torque (with a rubber sleeve ^{*2})
		The valve should be installed directly after the following: - a reducer which is 2 sizes smaller than a valve - a curved pipe - a straight pipe	0.5-2.0		Low torque
	Gas	Differential pressure 0.1-2.0 Mpa	2.0-10		Standard
Horizontal layout 	Liquid (Clean water)	The valve should be installed directly after the following: - a reducer which is 2 sizes smaller than a valve - a curved pipe - a straight pipe	2.0-10	50-200	Standard
				250-400	High torque
Down flow ^{*1} 			0.1-5.0	50-200	High torque

Table A Allowed velocity range

Nominal size	Allowed velocity
50A	1.2-10 m/s
65A	
80A	
100A	
125A	1.6-10 m/s
150A	
200A	
250A	2.2-10 m/s
300A	

*1 In case of down flow, there is possibility of leakage depending on condition when checking.

*2 Pressure loss increases with a rubber sleeves compared to standard torque spring.

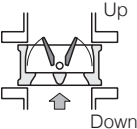
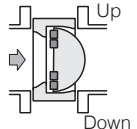
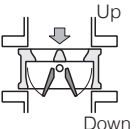
* If possible, avoid installing directly after a reducer. Install before a reducer.

* Do not use under the condition other than above to avoid vibration, abnormal noise, damage, and leakage.

* All 907T/908H over 250mm will be attached rubber sleeve.

Available Pipe List

List of Available Pipes for MKT for use with Welding Method in Fig. A

Nominal Diameter		SGP	Sch20	Sch40	Sch10S	Sch20S
mm	inch					
50	2	○	○	○	○	○
65	2 1/2	○	○	○	○	○
80	3	○	○	○	○	○
100	4	○	○	○	○	○
125	5	○	○	○	○	○
150	6	○	○	○	○	○
200	8	○	○	○	○	○
250	10	○	○	○	○	○
300	12	○	○	○	○	○
350*	14	○	○	○	○	○
400*	16	○	○	○	○	○

* Products with a nominal size of 350 or 400 mm are available only for 907T. They are made to order.

List of Available Pipes for MKT for use with Welding Method in Fig. B

Nominal Diameter		SGP	Sch20	Sch40	Sch10S	Sch20S
mm	inch					
50	2	○	○	○	○	○
65	2 1/2	○	○	○	○	○
80	3	○	○	○	○	○
100	4	○	○	○	○	○
125	5	○	○	○	○	○
150	6	○	○	○	○	○
200	8	○	○	○	○	○
250	10	○	○	○	○	○
300	12	○	○	○	○	○
350*	14	○	○	○	○	○
400*	16	○	○	○	○	○

Note 1) Meanings of the symbols in the above table are as shown below.

○ mark: Can be installed - mark: No standard

* Products with a nominal size of 350 or 400 mm are available only for 907T. They are made to order.

Min. Pipe Inner Diameter

Nominal Diameter		Min. Pipe Inner Diameter
mm	inch	
50	2	35.0
65	2 1/2	45.5
80	3	56.0
100	4	80.6
125	5	98.2
150	6	122.1
200	8	156.9
250	10	204.7
300	12	222.9
350*	14	259
400*	16	311

* Products with a nominal diameter of 350 or 400 mm are available only for 907T. They are made to order.

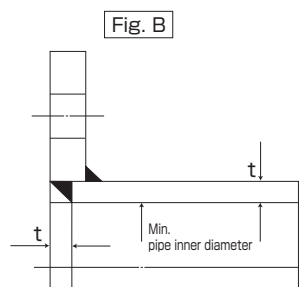
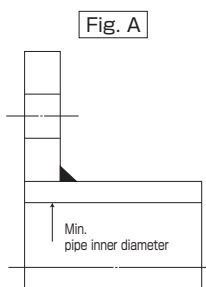

Cracking Pressure (Opening Pressure)

Minimum differential pressure required for fluid movement in a forward direction

Unit KPa

Installation orientation		Horizontal installation			Vertical installation (Flow from bottom to top)		
Spring Type		Low torque	Standard	High torque	Low torque	Standard	High torque
Nominal Diameter							
mm	inch	KPa	KPa	KPa	KPa	KPa	KPa
50	2	0.26	2.94	5.07	0.879	4.15	6.75
65	2 1/2	0.175	1.75	3.71	0.738	2.67	5.06
80	3	0.428	1.43	3.15	1.16	2.39	4.49
100	4	0.333	1.75	3.15	1.23	2.96	4.67
125	5	0.262	1.08	2.11	1.22	2.22	3.48
150	6	0.214	1.04	2.02	1.36	2.36	3.56
200	8	0.130	0.749	1.37	1.57	2.33	3.09
250	10	0.139	0.528	1.33	1.90	2.38	3.36
300	12	0.128	0.628	1.12	2.47	3.08	3.68
350	14	0.1320	0.545	0.941	2.52	3.02	3.50
400	16	0.0809	0.322	0.945	2.26	2.50	3.13

*Products with a nominal size of 350 or 400 mm are available only for 907T. They are made to order.

Quantity and Dimensions of Piping Bolts

Nominal Diameter		JIS10K	JIS16K	JIS20K	ASME B16.5 Class150
mm	inch	Long Bolt, Nuts	Long Bolt, Nuts	Long Bolt, Nuts	Long Bolt, Nuts
50	2	4-M16×140×35	8-M16×140×35	8-M16×140×35	4-U5/8-11×145×40
65	2 1/2	4-M16×150×40	8-M16×150×40	8-M16×150×40	4-U5/8-11×160×40
80	3	8-M16×160×40	8-M20×175×50	8-M20×175×50	4-U5/8-11×170×40
100	4	8-M16×160×40	8-M20×175×50	8-M20×175×50	8-U5/8-11×170×40
125	5	8-M20×180×50	8-M22×200×50	8-M22×200×50	8-U3/4-10×190×50
150	6	8-M20×200×50	12-M22×215×50	12-M22×215×50	8-U3/4-10×205×50
200	8	12-M20×230×50	12-M22×240×50	12-M22×240×50	8-U3/4-10×240×50
250	10	12-M22×260×50	12-M24×275×60	12-M24×275×60	12-U7/8-9×265×55
300	12	16-M22×300×50	16-M24×315×60	16-M24×315×60	12-U7/8-9×305×55
350	14	16-M22×300×50	16-M30 (P3) ×340×60	16-M30 (P3) ×340×60	12-U1×320×60
400	16	16-M24×310×60	16-M30 (P3) ×360×60	16-M30 (P3) ×360×60	16-U1×330×60

[Note] * Hexagon nut. The height is 80% of the nominal size.

●The bolt length conforms to JIS standards and the steel flange thickness.

* Material: SS400 (Unichrome plating)

* Products with a nominal diameter of 350 or 400 mm are available only for 907T. They are made to order.

[Indication Example]

Long bolt : 16 - M22 × 300 × 45

Q'ty Nominal diameter (M) Bolt length (L) Effective thread length (S)

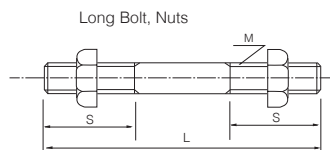

Before Placing an Order

General Product Warranty

Tomoe warrants that the product is free from defects in material and workmanship under normal use and operation.

The warranty period is 12 months from the commencement of the use (including the test use) of the product, or for 18 months from the shipment of the product from Tomoe's factory, whichever expires earlier.

Tomoe will, without charge, repair or replace, in its sole discretion, such product that, in the opinion of Tomoe, is found to be defective within the warranty period.

This warranty only applies to the Tomoe products delivered from Tomoe or its authorized subsidiaries and distributors. Except as explicitly provided herein, Tomoe neither provides any warranty, whether express or implied, with respect to the products (including, but not limited to, warranties of merchantability or fitness for a particular purpose and non-infringement of any third party's intellectual property rights), nor provides any remedy with respect to a defective product including, but not limited to, any compensation of damages resulting from the defect of the product or malfunction of the equipment or machinery that uses the product. In no event shall Tomoe be liable for any incidental, indirect, special or consequential damage of any nature whatsoever.

This warranty does not cover the normal wear and tear of any expendable parts, such as seat rings and gland packing, that occurs through the normal use of the product, or any defect in the products that occurs under any of the following circumstances. In such cases, Tomoe may, subject to its consent, repair or replace the defective product for a fee.

- 1) The defect is caused by the product being used or handled under conditions, or in an environment, or in a manner, or by means other than in strict accordance with the instructions in the catalog, product specifications and operating instructions.
- 2) The defect is caused by the product or any part thereof being altered, adjusted, dismantled, modified or repaired, or any part of the product being removed or replaced, by any person not authorized by Tomoe to do so.
- 3) The defect is caused by products which are not supplied by Tomoe.
- 4) The defect is caused wholly or partly by any drawings or specifications supplied or approved by you (the purchaser) or by any materials, parts or components supplied by you or bought at your instruction.
- 5) The defect is caused by inadequate or inappropriate inspection or maintenance of the product or the equipment or machinery that uses the product (including, without limitation, poor replenishment of consumables such as lubricant).
- 6) The defect is caused by high frequency of use or operation of the product or the equipment or machinery that uses the product (including, without limitation, high frequency opening and closing thereof).
- 7) The defect is caused by any problem or trouble related to power or air supply to the equipment or machinery that uses the product.
- 8) The defect is caused by inflow of foreign matter, such as dust, into the product.
- 9) The defect is caused by the product being stored in an inadequate or inappropriate condition, such as open-air storage.
- 10) The defect is caused by any reason that is beyond the control of Tomoe, including, without limitation, an act of war, act of public enemy, revolution, riot, act of god, flood, fire, earthquake, and so on.
- 11) The defect is caused by any other reason not attributable to Tomoe.

Paid Repair, Replacement and Supply of Parts for Discontinued Products

Tomoe reserves the right to change the design, or discontinue the production, of any products, without notice. Neither paid repair nor replacement of the products, nor supply of their parts, may be available after 5 years have passed from the change of design or discontinuance of production of such products. However, please note that paid repair or replacement of the products and/or supply of their parts may not be available during such 5 year period.

TOMOE VALVE CO., LTD. www.tomoevalve.com

● Head Office

3-11-11 Shinmachi, Nishi-ku, Osaka 550-0013, Japan
Telephone: 81-6-6110-2370 Telefax: 81-6-6110-2371 E-mail: sales@tomoevalve.com

Global Sales Operations

TOMOE VALVE INDUSTRY (NANTONG) CO., LTD. <http://www.tomoe.sh.cn>

No.23 ,Donghai Rd, Qidong Hi-tech Industrial Development Zone, Qidong City, Jiangsu Province, China
Telephone: +86(0)513-83921121 Telefax: +86(0)513-83921262 E-mail: sales@tomoe.sh.cn

TOMOE VALVE LIMITED www.tomoeurope.co.uk

Clearwater Road, Queensway Meadows Industrial Estate,
Newport, South Wales NP19 4ST, United Kingdom
Telephone: 44-1633-636800 Telefax: 44-1633-636801 E-mail: sales@tomoe.co.uk

TOMOE VALVE ASIA PACIFIC PTE. LTD. www.tomoe.com.sg

No. 2, Toh Guan Road East, #02-02, Singapore 608837
Telephone: +65-68995060 Telefax: +65-68995061 E-mail: sales@tomoe.com.sg

TOMOE VALVE (THAILAND) CO., LTD.

No. 317, Kamol Sukosol Building, Unit B, 12th Floor, Silom Road, Silom Sub-district, Bangrak District, Bangkok 10500, Thailand
Telephone: +66-(0)-2117-0429 Telefax: +66-(0)-2117-0148 E-mail: sales@tomoe.co.th

PT. TOMOE VALVE BATAM <http://www.tomoe-batam.com>

BlockF2 Latrade Industrial Park, Jl. Sei Binti Tanjung Uncang, Batam 29422 Indonesia
Telephone: +62-778-395-466 Telefax: +62-778-396-475 E-mail: sales@tomoe-batam.com

TOMOE VALVE (USA) LLC <http://www.tomoevalveusa.com>

808 Russell Palmer Road, Suite 101; Kingwood TX77339, U.S.A
Telephone: +1(281)358-7571 Telefax: +1(281)372-8340

■ CONTACT