

**841T** Wafer

**842T** Wafer



Valve nominal size

841T 350 to 600mm

842T 350 to 600mm

Max. Working pressure MPa Working temperature range degrees C

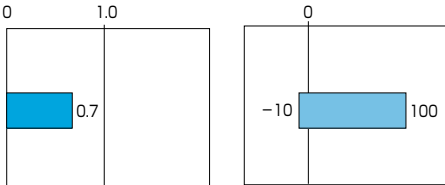

**CE** CE Marking (842T)

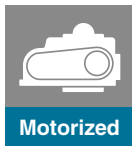

## Features and Benefits

### Bubble tight seal and no leakage

PTFE does not react to most of the chemicals used in modern chemical processing – even at high temperatures and high pressures. It is recognised as an ideal material for industrial valves that handle highly corrosive fluids. PTFE has a low friction coefficient and excellent lubricity when used in contact with metal surfaces.

TOMOE's 841T and 842T butterfly valves take full advantage of the superior qualities of PTFE: it protects all wetted parts and guides all stems. The 841T and 842T valves have a proven record of excellent performance and long life in heavy duty applications requiring tight shut-off, low torque and smooth operation.

### Triple seal prevents leakage

The special feature of TOMOE butterfly valves is the seat ring design. The interference between the disc and the raised central area of the seat ring shuts off the flow completely. The resilient elastomer seat cushion ensures reliable shut off for the life of the valve.

TOMOE butterfly valves are bi-directional and withstand pressures to 0.7 MPa from either direction.

The upper and lower positions of the seat ring, where the stem passes through, use a triple seal design to prevent leakage to the atmosphere as shown in the illustration.

## General Description

Chemically resistant butterfly valves with a proven record of excellent performance and long life in heavy duty applications.

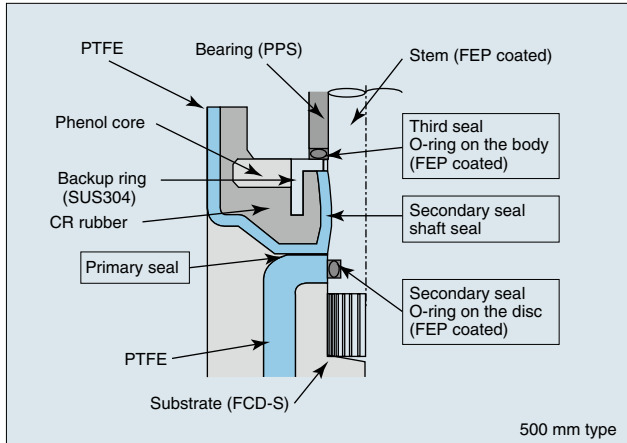

## Where you can see advantages over other types of valves

- In corrosion resistant pipelines requiring mechanical strength as well as heat resistance.  
Chemical Industry: Chlorine gas, acetic acid, sulfuric acid, hydrochloric acid, and other highly corrosive fluids.
- In non-toxic environments where the fluid must not contact any metallic or organic materials.  
Food Industry: Cooking oil, seasoning, syrup, and other food products.
- In reduced pressure or high temperature pipelines where conventional valves cannot be used because of piping space requirements and valve weight.  
General Industry: Steam lines, hot air, special process gases, dyes, and so on.
- In processes involving hazardous fluids that require clean pipelines free from machining burrs, scales, and grease.  
Piping: Pipelines for oxygen and other highly oxidizing agents.
- In processes requiring sanitation or vacuum service.  
vacuum service.  
Handling: Processing food, transporting powder or granular solids.
- In low temperature processes where low heat gain is an advantage.  
Cooling: Cooling air, chilled water, and brine.

## Standard Specifications

Type	841T	842T	
Body shape (centring method)	Concentric design, wafer type		
Valve nominal size	350, 400, 450, 500, 600mm	350, 400, 450, 500, 600mm	
Flange accommodation	JIS 10K, ASME Class 125/150, DIN PN10, BS 4504 PN10, BS 10Table E		
Face-to-face dimensions	Manufacturer standard		
Max. working pressure	0.7 MPa		
Seat leakage	Tight shut-off		
Flow direction	Bi-directional		
Pressure test	Body shell	1.05 MPa (Hydraulic)	
	Seat leakage	0.7 MPa (Hydraulic)	
Working temperature range	- 10 to 100 degrees C		
Working temperature in continuous use ※1	0 to 90 degrees C		
Standard materials	Body	FCD-S	
	Disc	SCS14	FCD-S+ PTFE lining
	Stem	SUS316	S45C+FEP coating
	Seat ring	PTFE (back-up rubber: CR)	
Top flange	Manufacturer standard		
Applicable gaskets	Rubber gasket cannot be used. Moulded gaskets require special dimensions (refer to dimension chart). Off-the-shelf seat gaskets can be used for 250 to 400mm. 450 to 600mm require special inner diameter dimensions (refer to dimension chart).		
Coating	350mm and larger: Lacquer primer (Munsell N7)		

※1 "Working temperature in continuous use" stands for the temperature continuously kept exceeding one hour.

※2 Export license by Japanese Ministry is required 842T for all sizes. Please consult us the detail.

# 841T/842T

## 841T / 842T Expanded View of Components

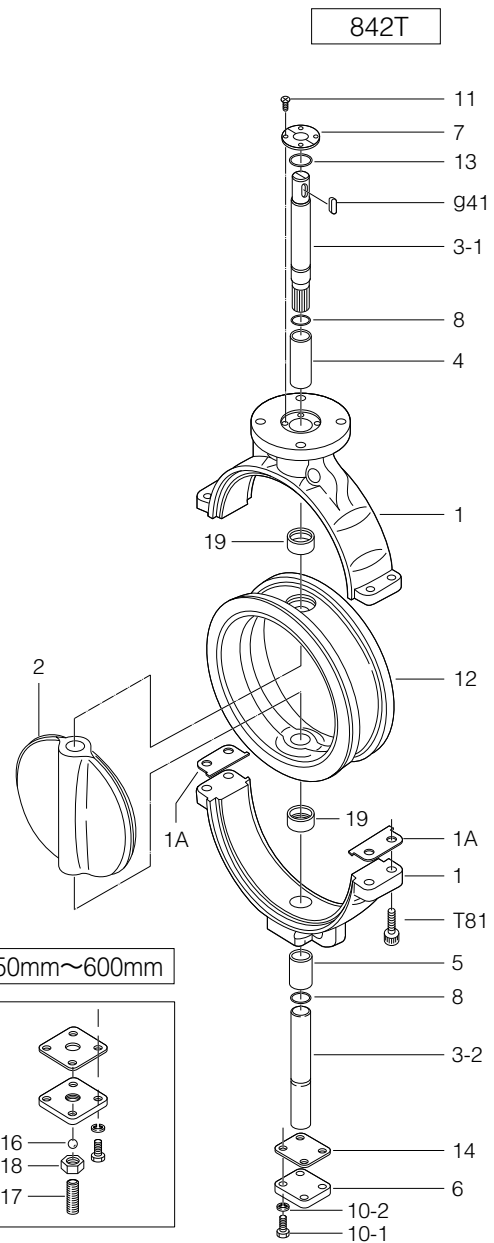
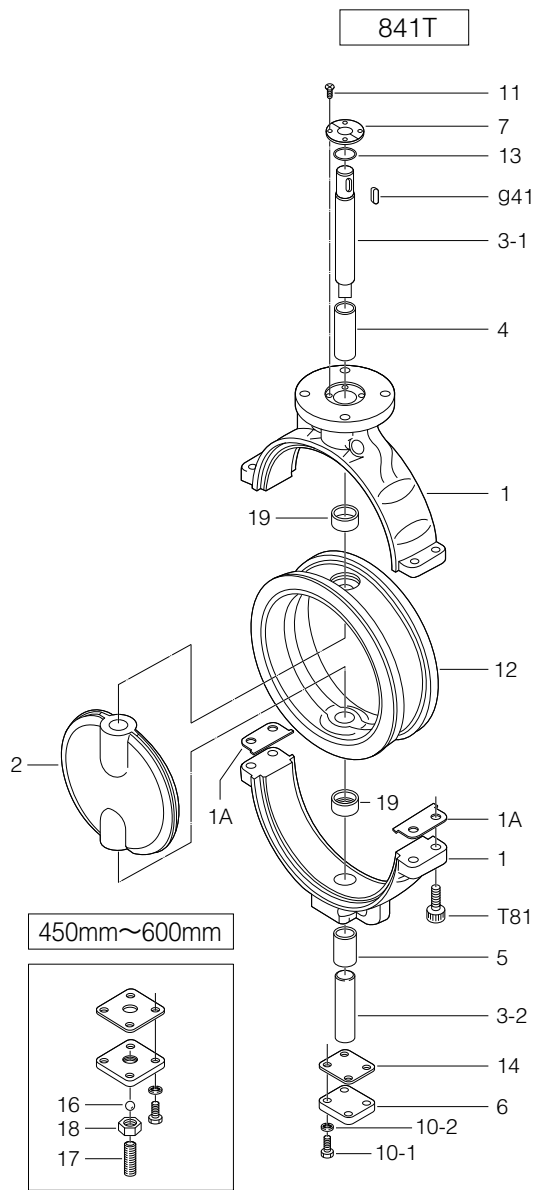

## 841T / 842T Parts list

### ■ 841T Parts list

No.	Description	Q'ty	Remarks
1	Body	1	
★ 1A	Packing	2	
2	Disc	1	
3-1	Upper stem	1	
3-2	Lower stem	1	
★ 4	Bushing	1	
★ 5	Bushing	1	
6	Bottom cover	1	
7	Retainer plate	1 Set	
10-1	Hexagon bolt	4	
10-2	Spring washer	4	
11	Machine screw	4	
★ 12	Seat ring	1	
★ 13	O-ring	1	
14	Gasket	1	
16	Ball	1	Only 450mm to 600mm
17	Hollow bolt	1	Only 450mm to 600mm
18	Lock nut	1	Only 450mm to 600mm
19	Back-up rubber	2	
T81	Hexagon hole bolt	4	
g41	Key	1	

### ■ 842T Parts list

No.	Description	Q'ty	Remarks
1	Body	1	
★ 1A	Packing	2	
2	Disc	1	
3-1	Upper stem	1	
3-2	Lower stem	1	
★ 4	Bushing	1	
★ 5	Bushing	1	
6	Bottom cover	1	
7	Retainer plate	1 Set	
★ 8	O-ring	2	
10-1	Hexagon bolt	4	
10-2	Spring washer	4	
11	Machine screw	4	
★ 12	Seat ring	1	
★ 13	O-ring	1	
14	Gasket	1	
16	Ball	1	Only 450mm to 600mm
17	Hollow bolt	1	Only 450mm to 600mm
18	Lock nut	1	Only 450mm to 600mm
19	Back-up ring	2	
T81	Hexagon hole bolt	4	
g41	Key	1	

Remark: The ★ indicates recommended spare parts. They are supplied as "Seat ring set".

# 841T/842T

## 841T/842T Actuator selection chart

### 841T/842T

Model	Category	Size (mm / inch)				
		350	400	450	500	600
		14	16	18	20	24
2S	Standard	MGH-3				MGH-4
	Heavy duty					
3A	Standard	TGA-125	TGA-140	TGA-160	TGA-200	
	Heavy duty	TGA-140	TGA-160	TGA-180		
3U,3K	Standard	TG-14S			TG-20S	
	Heavy duty					
4 I	ON-OFF	4 I-4				
	Control					
4L	Standard	LTKD-01 0.4kW/MGH-3		LTKD-02 0.75kW/MGH-3	LTKD-05 0.75kW/MGH-4	
	Heavy duty					

Selection criteria	Standard	Select when none of the following heavy duty items apply.
	Heavy duty	Select when any of the following items apply. ① Powder or high viscosity fluid (crude oil, etc.) ② Control specification (with positioner) ③ Emergency open valve or pipe dead end valve

## 841T/842T Pressure-temperature rating

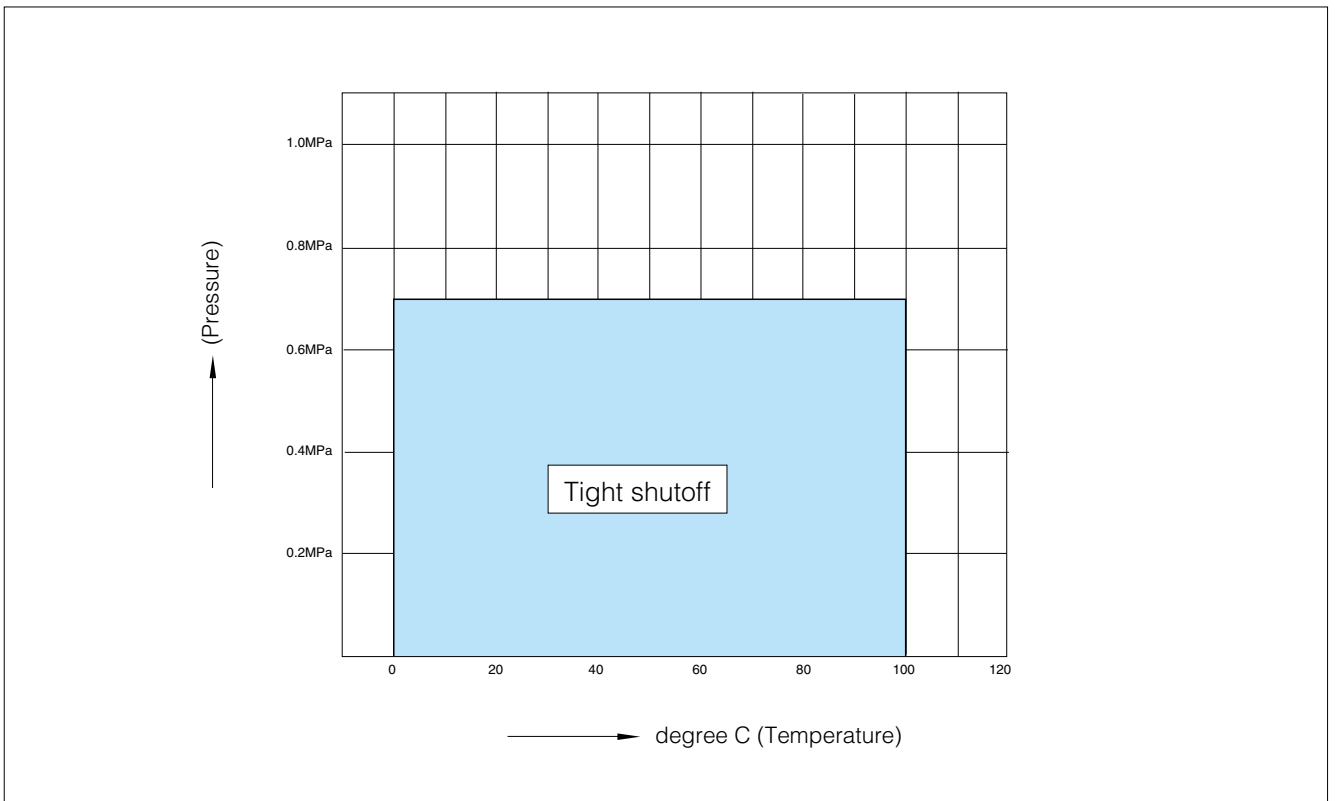

Bare shaft 841T-02(350mm to 600mm) / 842T-02(350mm to 600mm)

■841T/842T

Nominal size		Dimension (mm)														Approx. Mass (kg)	
mm	inch	$\phi d$	$\phi D$	L	H <sub>1</sub>	H <sub>2</sub>	a <sub>1</sub>	a <sub>2</sub>	$\phi d_2$	b	t <sub>2</sub>	t	D <sub>1</sub>	C <sub>1</sub>	N		B.H.
350	14	332	428	100	293	320	50	43	40	10	3.5	20	200	170	4	19	60
400	16	383	491	110	323	360	50	43	40	10	3.5	20	200	170	4	19	80
450	18	435	540	120	367	390	60	53	47	12	3.5	20	200	170	4	19	123
500	20	482	595	140	383	420	60	53	47	12	3.5	20	200	170	4	19	188
600	24	581	700	160	478	490	75	65	65	18	6	25	260	220	4	23	266

■841 T 350mm to 600mm

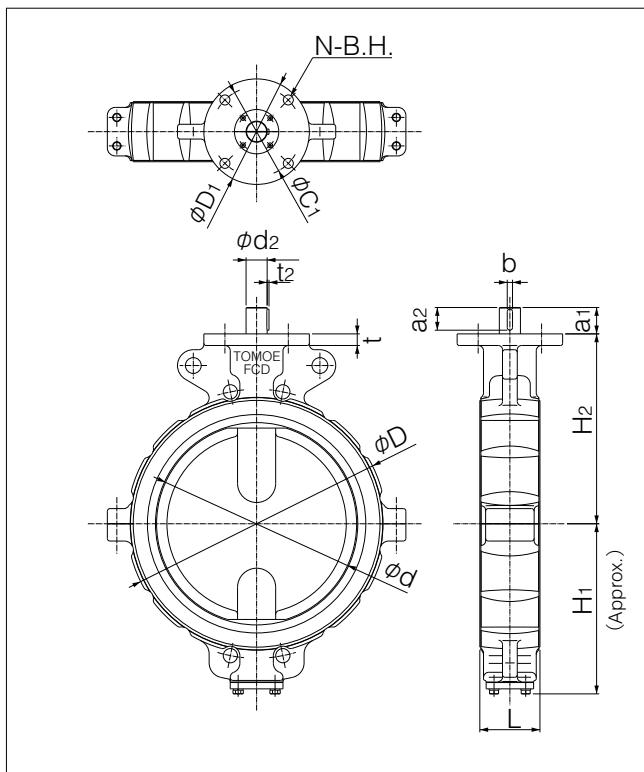

■842 T 350mm to 600mm

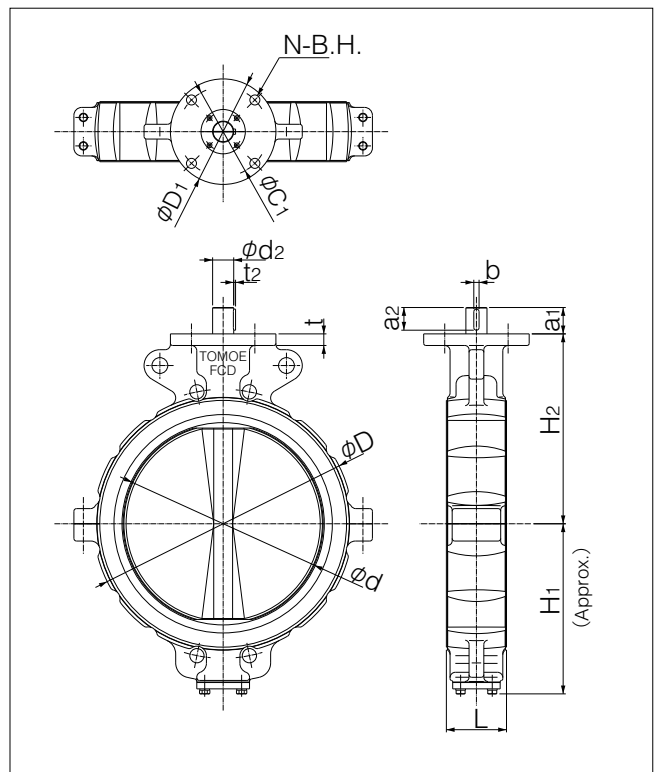

# 841T/842T

Worm gear type 841T-2S (350mm to 600mm) / 842T-2S (350mm to 600mm)

## 841T/842T

Nominal size		Dimension (mm)										Gear type	Approx. Mass (kg)
mm	inch	$\phi d$	$\phi D$	L	H <sub>1</sub>	H <sub>2</sub>	H <sub>3</sub>	E	K	F	W		
350	14	332	428	100	293	320	55	117	164	325	280	MGH-3	93
400	16	383	491	110	323	360	55	117	164	325	280	MGH-3	113
450	18	435	540	120	367	390	55	117	164	335	355	MGH-3	155
500	20	482	595	140	383	420	55	117	164	335	355	MGH-3	220
600	24	581	700	160	478	490	65	140	198	400	450	MGH-4	320

## 841T/842T-2S

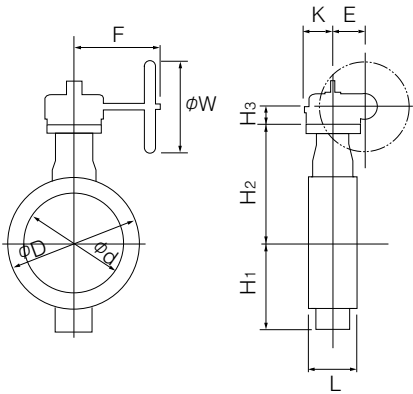

## 2S Installation direction

2SA (standard)	2SAR	2SB	2SBR

Double-acting pneumatic cylinder type 841T-3A (350mm to 600mm) / 842T-3A (350mm to 600mm)

■ Standard

Nominal size		Dimension (mm)										Cylinder type	Approx. Mass (kg)
mm	inch	$\phi d$	$\phi D$	L	H <sub>1</sub>	H <sub>2</sub>	H <sub>3</sub>	A	P	f <sub>1</sub>	f <sub>2</sub>		
350	14	332	428	100	293	320	359	754	381	100	167	TGA-125	106
400	16	383	491	110	323	360	407	840	432	100	183	TGA-140	139
450	18	435	540	120	367	390	435	954	471	130	205	TGA-160	220
500	20	482	595	140	383	420	435	954	471	130	250	TGA-160	260
600	24	581	700	160	478	490	570	1175	576	160	254	TGA-200	450

■ Heavy duty

Nominal size		Dimension (mm)										Cylinder type	Approx. Mass (kg)
mm	inch	$\phi d$	$\phi D$	L	H <sub>1</sub>	H <sub>2</sub>	H <sub>3</sub>	A	P	f <sub>1</sub>	f <sub>2</sub>		
350	14	332	428	100	293	320	407	754	381	100	167	TGA-140	106
400	16	383	491	110	323	360	435	840	432	130	183	TGA-160	190
450	18	435	540	120	367	390	478	954	471	130	205	TGA-180	252
500	20	482	595	140	383	420	478	954	471	130	250	TGA-180	292
600	24	581	700	160	478	490	570	1175	576	160	254	TGA-200	450

■ 841T/842T-3A

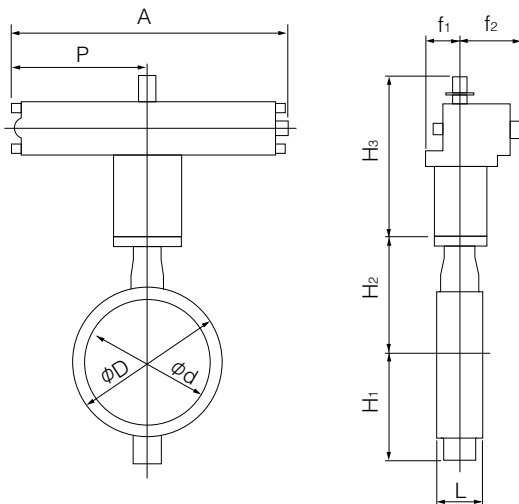

Selection criteria	Standard	Select when none of the following heavy duty items apply.
	Heavy duty	Select when any of the following items apply. ① Powder or high viscosity fluid (crude oil, etc.) ② Control specification (with positioner) ③ Emergency open valve or pipe dead end valve

■ 3A Installation direction

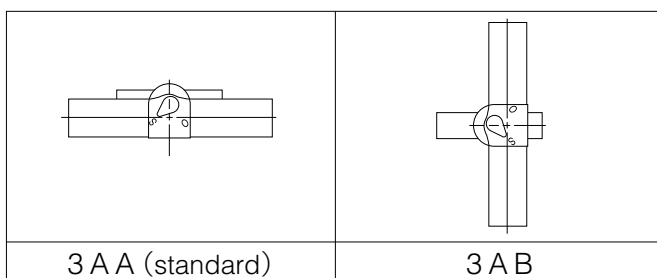



# 841T/842T

Single-acting pneumatic cylinder type 841T-3U (Air to open: 250mm to 600mm) / 841T-3K (Air to close: 250mm to 600mm)  
 842T-3U (Air to open: 350mm to 600mm) / 842T-3K (Air to close: 350mm to 600mm)

## Standard

Nominal size		Dimension (mm)										Cylinder type	Approx. Mass (kg)
mm	inch	$\phi d$	$\phi D$	L	H <sub>1</sub>	H <sub>2</sub>	H <sub>3</sub>	A	P	f <sub>1</sub>	f <sub>2</sub>		
350	14	332	428	100	293	320	340	1255	865	131	257	TG-14S	259
400	16	383	491	110	323	360	340	1255	865	131	257	TG-14S	279
450	18	435	540	120	367	390	340	1255	865	131	257	TG-14S	312
500	20	482	595	140	383	420	474	1655	1095	164	348	TG-20S	588
600	24	581	700	160	478	490	474	1655	1095	164	348	TG-20S	665

## Heavy duty

Nominal size		Dimension (mm)										Cylinder type	Approx. Mass (kg)
mm	inch	$\phi d$	$\phi D$	L	H <sub>1</sub>	H <sub>2</sub>	H <sub>3</sub>	A	P	f <sub>1</sub>	f <sub>2</sub>		
350	14	332	428	100	293	320	340	1255	865	131	257	TG-14S	259
400	16	383	491	110	323	360	474	1655	1095	164	348	TG-20S	483
450	18	435	540	120	367	390	474	1655	1095	164	348	TG-20S	523
500	20	482	595	140	383	420	474	1655	1095	164	348	TG-20S	588
600	24	581	700	160	478	490	474	1655	1095	164	348	TG-20S	655

Selection criteria	Standard	Select when none of the following heavy duty items apply.
	Heavy duty	Select when any of the following items apply. ① Powder or high viscosity fluid (crude oil, etc.) ② Control specification (with positioner) ③ Emergency open valve or pipe dead end valve

## 841T/842T-3U

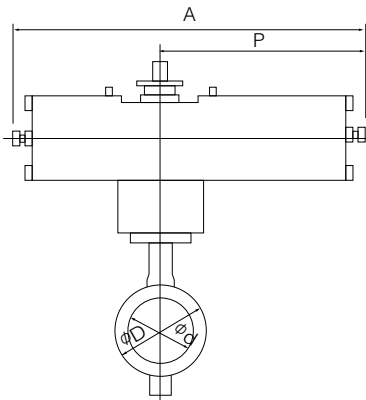

## 841T/842T-3K

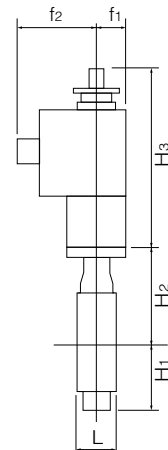
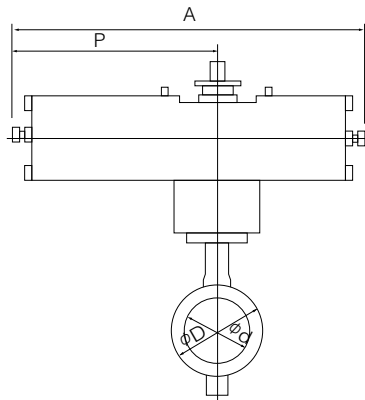

## 3U Installation direction

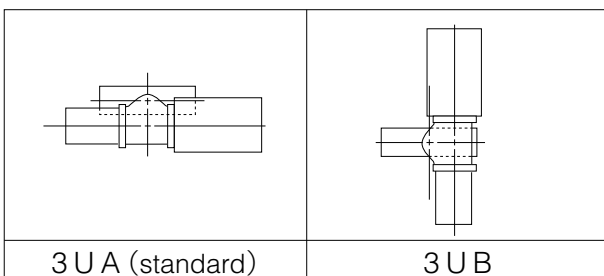

## 3K Installation direction

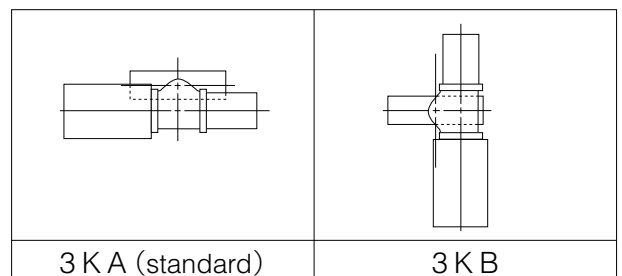

Single phase electric motor type 841T-4I(350mm to 450mm) / 842T-4I(350mm to 450mm)

■841T/842T

Nominal size		Dimension (mm)										Motor type	Approx. Mass (kg)
mm	inch	$\phi d$	$\phi D$	L	H <sub>1</sub>	H <sub>2</sub>	H <sub>3</sub>	A	P	F	K		
350	14	332	428	100	293	320	233	388	223	246	136	4I-4	89
400	16	383	491	110	323	360	233	388	223	246	136	4I-4	109
450	18	435	540	120	367	390	233	388	223	246	136	4I-4	158

■841T/842T-4I

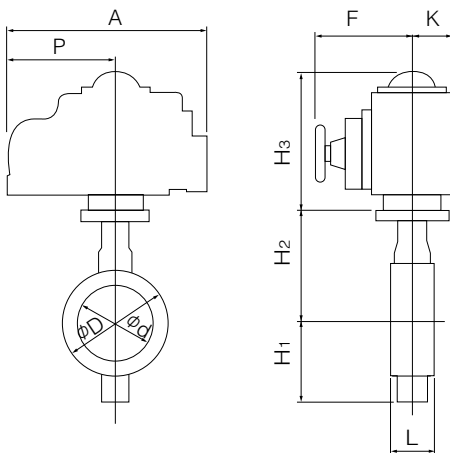

■4I Installation direction

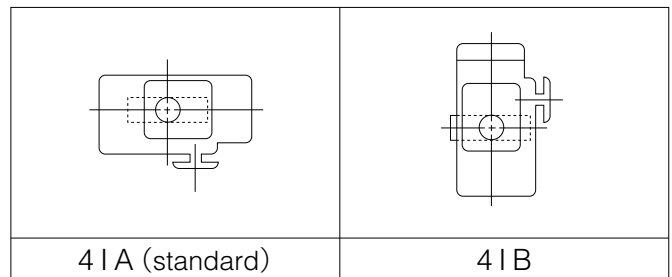

# 841T/842T

Three phase motor actuator type 841T-4L (350mm to 600mm) / 842T-4L (350mm to 600mm)

## 841T/842T

Nominal size		Dimension (mm)											Motor type	Approx. Mass (kg)
mm	inch	$\phi d$	$\phi D$	L	H <sub>1</sub>	H <sub>2</sub>	H <sub>3</sub>	E	K	F	M	P		
350	14	332	428	100	293	320	458	117	164	533	373	230	LTKD-01 0.4kW /MGH-3	189
400	16	383	491	110	323	360	458	117	164	533	373	230	LTKD-01 0.4kW /MGH-3	209
450	18	435	540	120	367	390	458	117	164	533	373	230	LTKD-01 0.4kW /MGH-3	252
500	20	482	595	140	383	420	492	117	164	567	370	230	LTKD-02 0.75kW /MGH-3	337
600	24	581	700	160	478	490	570	140	198	637	440	230	LTKD-05 0.75kW /MGH-4	505

## 841T/842T-4L

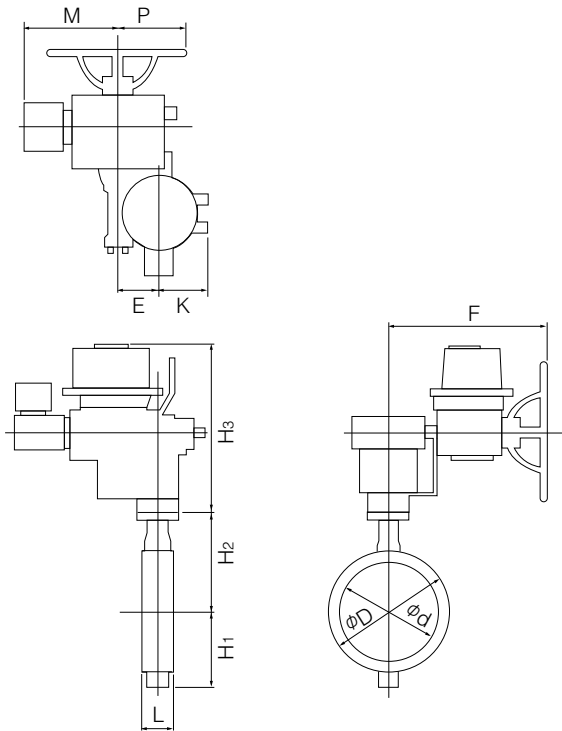

## 4L Installation direction

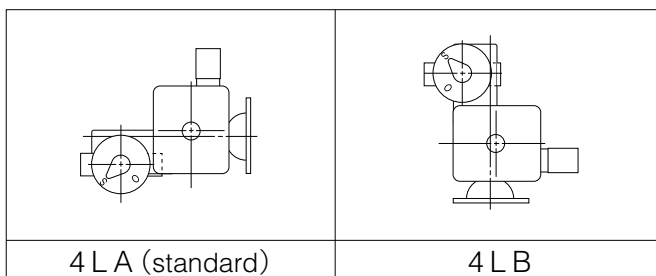

## 841T Cv value/pressure loss coefficient

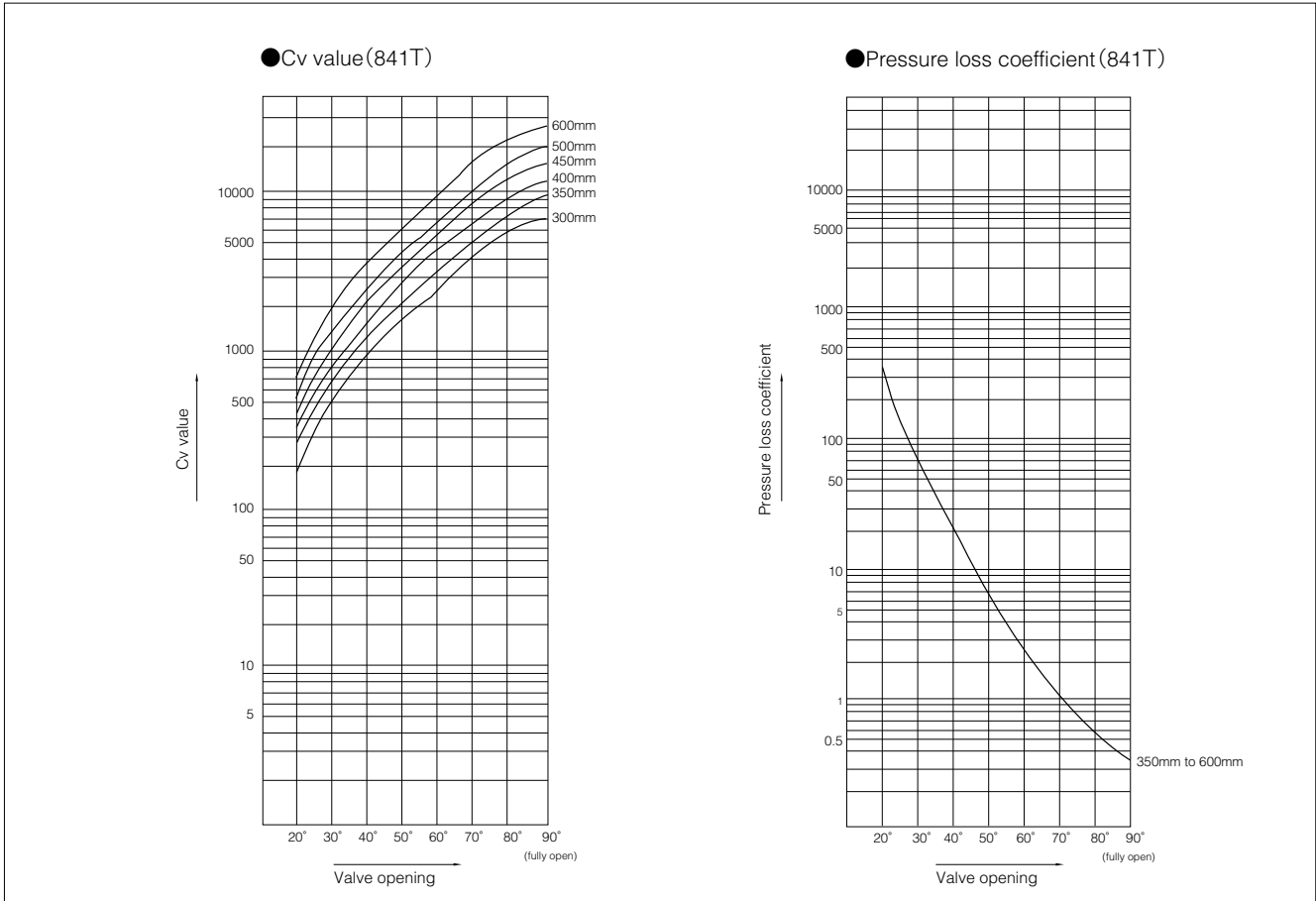

### 841T Cv value

Nominal size		Valve opening							
		20°	30°	40°	50°	60°	70°	80°	90°
mm	inch								
350	14	220	640	1235	2100	3350	5300	7800	9200
400	16	302	860	1643	2700	4300	6800	10300	12000
450	18	390	1140	2120	3400	5500	9100	13100	15500
500	20	478	1395	2600	4200	6800	11000	16000	19000
600	24	695	2080	3780	6100	9900	16000	23000	27600

### 841T Pressure loss coefficient

Nominal size		Valve opening							
		20°	30°	40°	50°	60°	70°	80°	90°
mm	inch								
350	14	600	68	19	7	3	1	0.4	0.3
400	16	606	66	19	7	3	1	0.4	0.3
450	18	611	61	18	7	3	1	0.4	0.3
500	20	619	64	19	7	3	1	0.4	0.3
600	24	618	63	18	7	3	1	1	0.3

# 841T/842T

## 842T Cv value/pressure loss coefficient

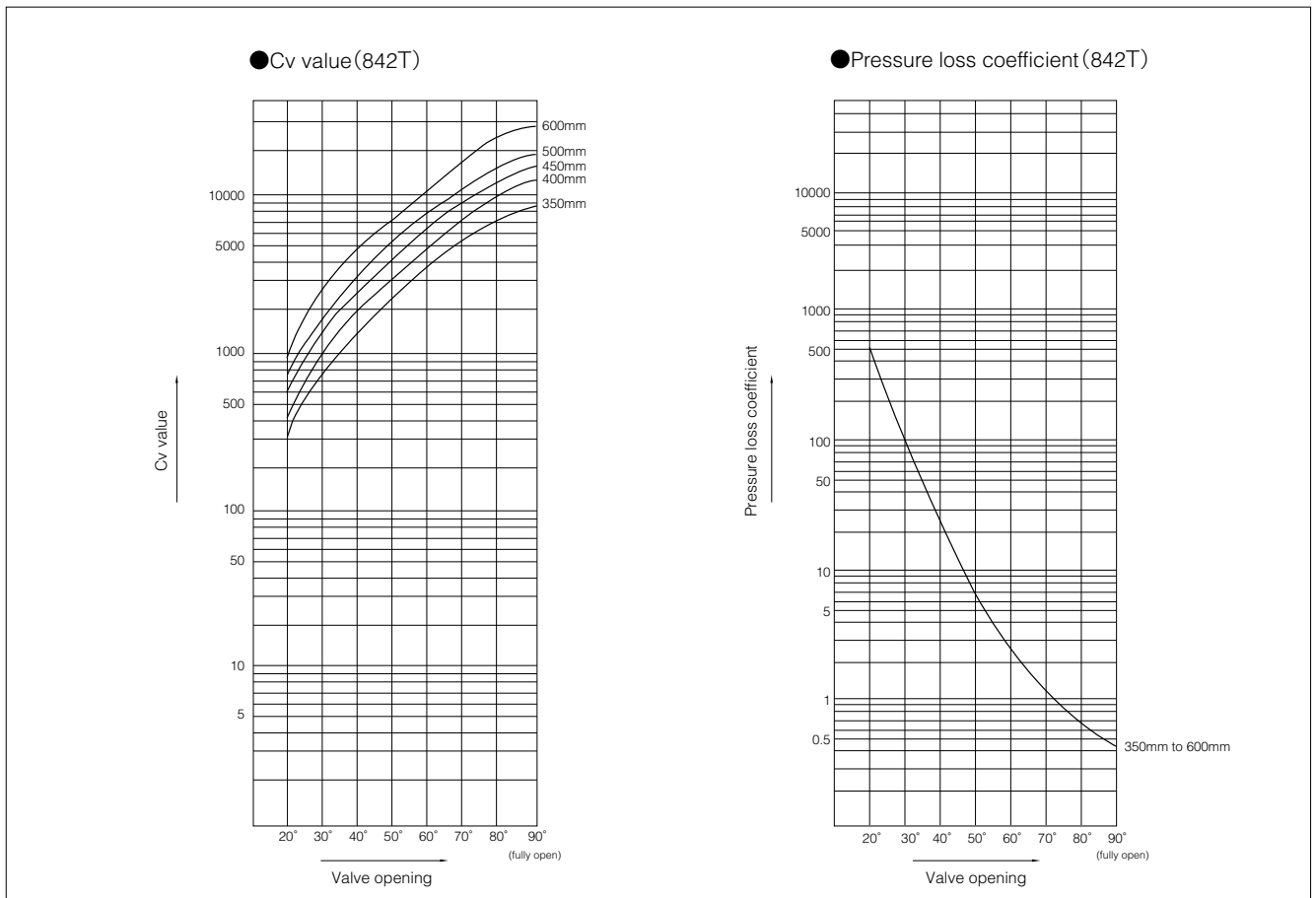

### 842T Cv value

Nominal size		Valve opening							
mm	inch	20°	30°	40°	50°	60°	70°	80°	90°
350	14	270	800	1450	2300	3600	5400	7400	8800
400	16	360	1100	1950	3000	4300	7400	11000	12000
450	18	460	1400	2500	4000	6200	9500	13000	15000
500	20	560	1700	3200	4800	7600	11500	15500	18000
600	24	820	2500	4500	7000	11500	17000	23000	26000

### 842T Pressure loss coefficient

Nominal size		Valve opening							
mm	inch	20°	30°	40°	50°	60°	70°	80°	90°
350	14	354	49	13	6	2	1	1	0.3
400	16	337	44	13	5	2	1	1	0.3
450	18	261	48	15	5	2	1	1	0.3
500	20	365	49	13	6	2	1	1	0.3
600	24	345	46	13	6	2	1	1	0.3

### 841T/842T Flange accommodation

Nominal size		JIS 10K	ASME		BS4504 PN10	DIN NP10	BS10 Table E
mm	inch		class 125	class 150			
350	14	D	D	D	D	D	D
400	16	D	D	D	D	D	D
450	18	T	T	T	T	T	T
500	20	T	T	T	T	T	X
600	24	T	T	T	T	T	X

D: With flange drilling  
T: With flange tapping  
X: Not applicable

### 841T/842T Applicable pipe list in case of **A**

Nominal size		SGP	Sch20	Sch40	VP (TS Flange)	Sch10S	Sch20S	Minimum internal diameter of piping (mm)
mm	inch							
350	14	○	○	○	○	—	—	322
400	16	○	○	○	—	—	—	372
450	18	○	○	○	—	—	—	421
500	20	○	○	○	—	—	—	463
600	24	—	○	○	—	—	—	566

### 841T/842T Applicable pipe list in case of **B**

Nominal size		SGP	Sch20	Sch40	Sch10S	Sch20S
mm	inch					
350	14	○	○	○	—	—
400	16	○	○	○	—	—
450	18	○	○	○	—	—
500	20	○	○	○	—	—
600	24	—	○	—	—	—

Remark 1: ○=Applicable

Remark 2: Butterfly valves are inserted into a pipe that was fitted with the disc when fully open.

In cases where you are using a pipe or flange that is less than the minimum inner pipe diameter, use is still possible if means are taken such as inserting a spacer between the valve and flange. For details, please consult us.

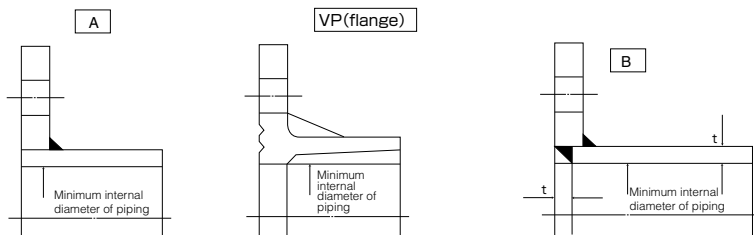

# 841T/842T

## 841T/842T Applicable gasket dimensions

Nominal size		841T/842T			
mm	inch	Recommended effective sealing I.D. (mm)	Max. effective sealing I.D. (mm)	Minimum I.D. (mm)	Min. effective sealing I.D. (mm)
350	14	359	359	332	416
400	16	410	410	383	479
450	18	457	457	435	533
500	20	508	508	482	590
600	24	610	610	581	693

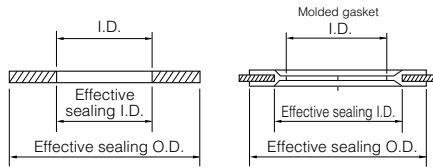

## 841T/842T Applicable standard for piping gasket list

Nominal size		Recommended effective sealing I.D. (mm)	Sheet gasket		PTFE molded gasket	
mm	inch		JIS10K	ASME class 125/150	JIS10K	ASME class 125/150
350	14	359	○	○	×	×
400	16	410	○	○	×	×
450	18	457	×	×	×	×
500	20	508	×	×	×	×
600	24	610	×	×	×	×

- : Standard gasket can be used  
 × : Standard gasket cannot be used. Use one with special dimensions.

## 841T/842T Piping bolt and nut sizes

### ■ Piping bolts sizes

Nominal size		JIS 10K		ASME class 125 / 150	
mm	inch	Long bolts and nuts	Setting bolts	Long bolts and nuts	Setting bolts
350	14	16-M22×215×45	—	12-U1 ×260×60	—
400	16	16-M24×230×50	—	16-U1 ×260×60	—
450	18	16-M24×245×50	8-M24×70×54	12-U1 1/8×285×65	8-U1 1/8× 85×70
500	20	16-M24×265×50	8-M24×70×54	16-U1 1/8×310×65	8-U1 1/8× 90×70
600	24	20-M30×300×60	8-M30×80×66	16-U1 1/4×345×70	8-U1 1/4×100×70

- Remarks:  
 1. Use thin hexagon nuts. For ASME class 125/150, use heavy hexagon nuts.  
 2. If the nominal diameter of the unified screw exceeds 1 inch, make the threading 8 threads per inch.  
 3. The table above does not apply if the material used is a special material which is not SS400.

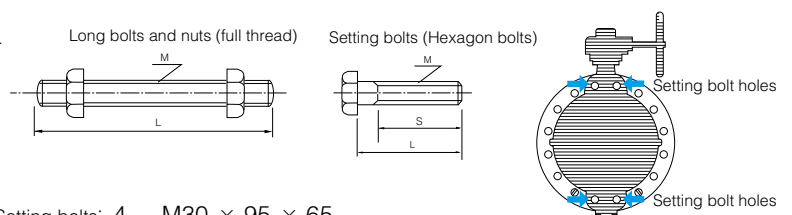

Example

Long bolts: 12 - M22 × 185 × 46  
 |        |        |        |  
 N        M        L        S

Setting bolts: 4 - M30 × 95 × 65  
 (Hexagon bolts) |        |        |        |  
 N        M        L        S

# MEMO
