

10 BAR Rated Butterfly Valve for General & Marine Use

704G Lugged

722F Double flanged

720F Double flanged

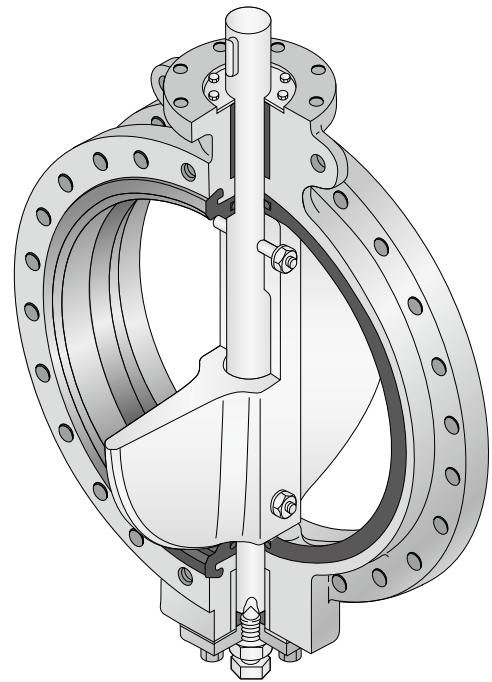
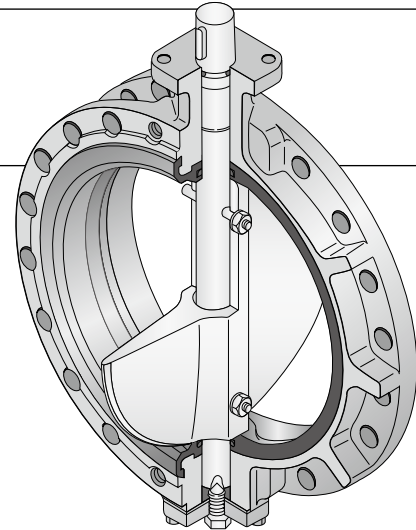
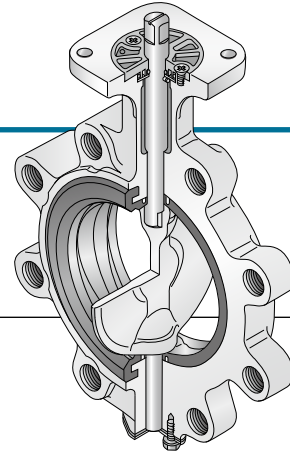

Today's ships have to work hard. With the extensive use of automated systems, minimum manning levels, extended journeys and quick turn round times, maintenance time is at a premium. Equipment must be ultra reliable and also meet the latest standards.

Features and Benefits

Long life and leak tight

The 704G/722F/720F are designed to meet all of these requirements. They are tough valves made to international standards with worldwide marine approvals. Long term leak tightness was achieved through attention to detail in the spindle sealing and seat design.

Low cost maintenance

The seat and disc can easily be replaced under a planned maintenance schedule. This ease of replacement does not affect the valve's function as the seat is positively located in machined grooves in the valve body.

Certification/Approval

Satisfies requirements of the major certification/approval bodies such as:

- Lloyd's Register of Shipping (LR)
- American Bureau of Shipping (ABS)
- Nippon Kaiji Kyokai (NK)
- Bureau Veritas (BV)

Standard Specifications

Type	704G	722F	720F
		Lugged type	Flanged type
Valve nominal size	50mm to 100mm ※1	125mm to 800mm	850mm to 1350mm
Flange accommodation ※2	JIS 10K, (JIS 5K, ASME Class 125/150, BS 4504 PN10)		
Max. working pressure	1.0MPa		
Body shell test	1.5MPa		
Seat leak test	1.1MPa		
Working temperature range	NBR : -10 to 80 degrees C, *EPDM : -20 to 120 degrees C		
Working temperature in continuous use ※3	NBR : 0 to 60 degrees C, *EPDM : 0 to 70 degrees C		
Standard materials ※4	Body	Cast steel, SCPH2	
	Disc	SCS 14 (316SS)	SCS 13 (304SS)
	Stem	SUS 420J2	SUS 403
	Seat ring ※5	NBR, *EPDM	
Coating	Lacquer primer (Munsell N7)		

- ※1 Available up to 600mm.
- ※2 Not all flange standards is applicable to all sizes. See "Flange accommodation" on p.414 for detail.
- ※3 'Working temperature in continuous use' stands for the temperature continuously kept exceeding one hour.
- ※4 Other materials, such as ductile iron body, aluminium bronze disc, etc, are also available. Consult us.
- ※5 Seating on 1000mm types and above are vulcanized to the body.
- * Never use an EPDM rubber seat ring if the valve is being used for oil or for a fluid containing even a slight amount of oil.

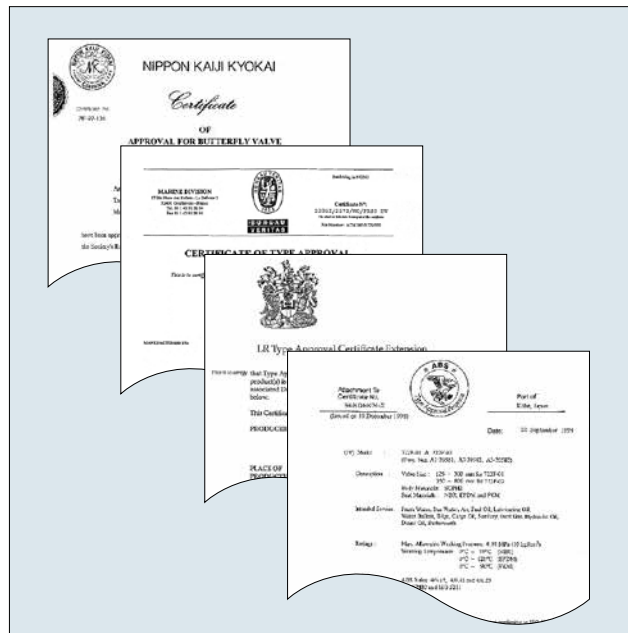

704G Expanded View of Components

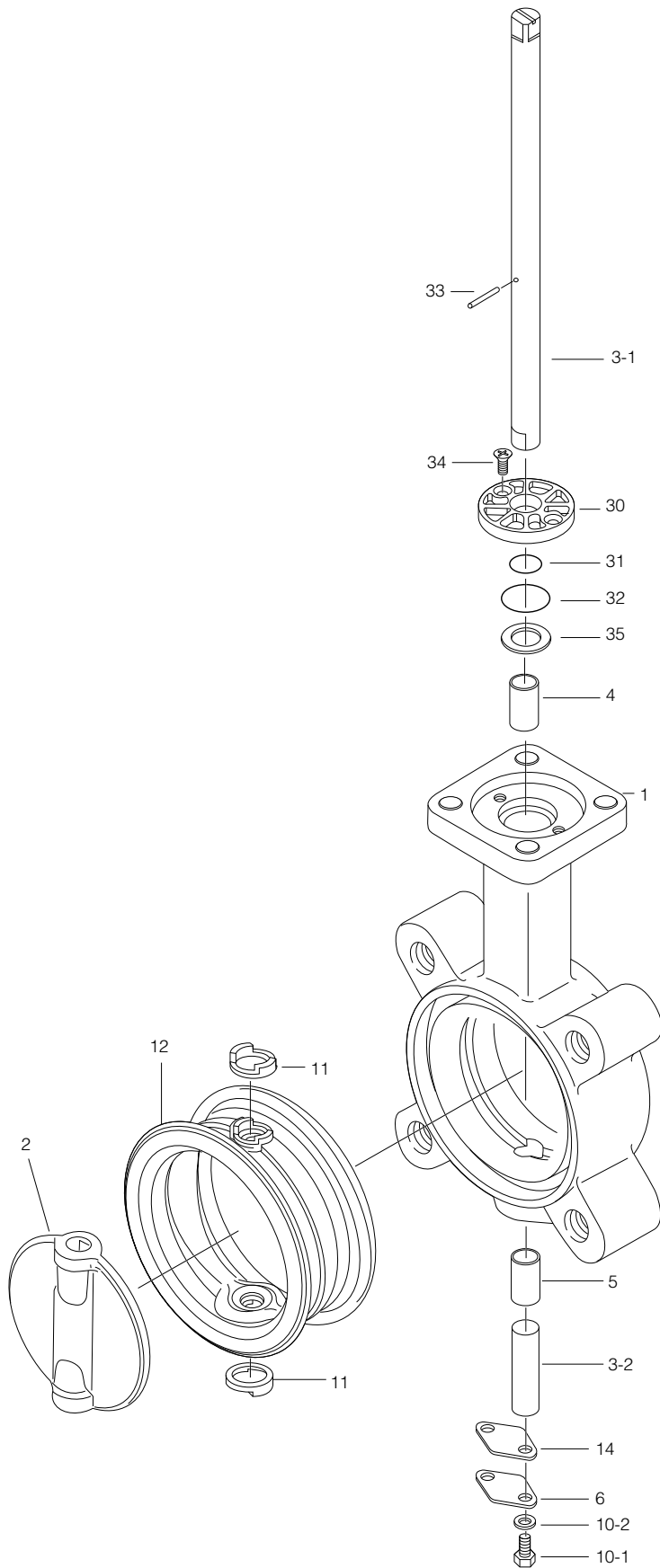

704G Parts list

■ 704G Parts list (50mm to 100mm)

No.	Description	Q'ty	Remarks
1	Body	1	
2	Disc	1	
3-1	Upper stem	1	
3-2	Lower stem	1	
4	Bearing	1	
5	Bearing	1	
6	Bottom cover	1	
10-1	Hexagon bolt	2	
10-2	Spring washer	2	
★ 11	Secondary ring	2	
★ 12	Seat ring	1	
★ 14	Gasket	1	
★ 30	Bushing	1	
★ 31	O-ring	1	
★ 32	O-ring	1	
33	Spring pin	1	
34	Machine screw	2	
35	Plate	1	

Remark: The ★ indicates recommended spare parts. They are supplied as "Seat ring set".

722F Expanded View of Components

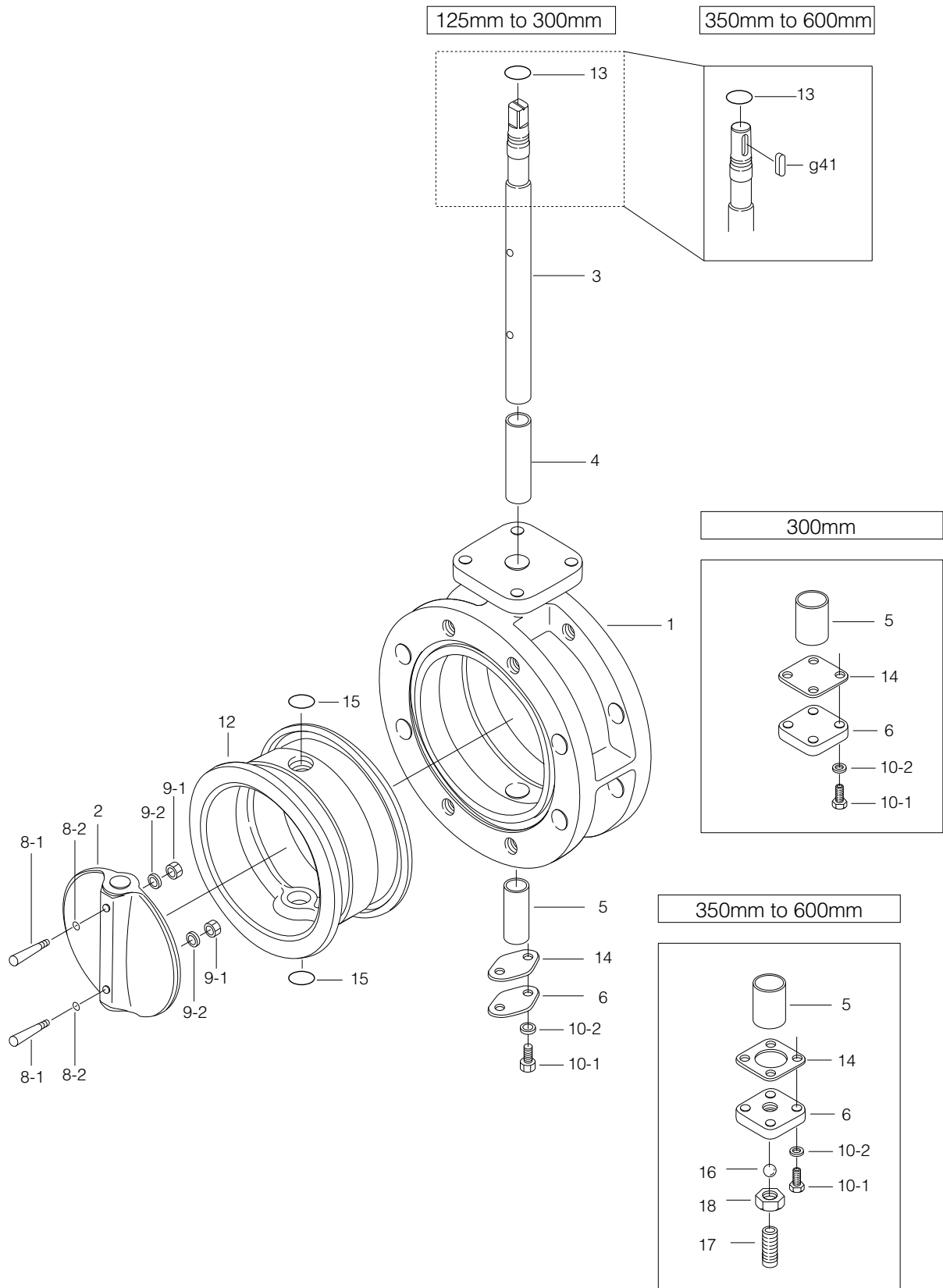

722F Parts list

■ 722F Parts list (125mm to 300mm)

No.	Description	Q'ty	Remarks
1	Body	1	
2	Disc	1	
3	Stem	1	
4	Bushing	1	
5	Bushing	1	
6	Bottom cover	1	
★ 8-1	Taper bolt	1	125mm
		2	150mm to 300mm
★ 8-2	O-ring	4	Only 300mm
★ 9-1	Hexagon nut	1	125mm
		2	150mm to 300mm
★ 9-2	Spring washer	1	125mm
		2	150mm to 300mm
10-1	Hexagon bolt	2	125mm to 250mm
		4	300mm
10-2	Spring washer	2	125mm to 250mm
		4	300mm
★ 12	Seat ring	1	
★ 13	O-ring	1	
★ 14	Sheet packing	1	
★ 15	O-ring	2	See Remark 2.

■ 722F Parts list (350mm to 600mm)

No.	Description	Q'ty	Remarks
1	Body	1	
2	Disc	1	
3	Stem	1	
4	Bushing	1	
5	Bushing	1	
6	Bottom cover	1	
★ 8-1	Taper bolt	2	
★ 8-2	O-ring	4	
★ 9-1	Hexagon nut	2	
★ 9-2	Spring washer	2	
10-1	Hexagon bolt	4	
10-2	Spring washer	4	
★ 12	Seat ring	1	
★ 13	O-ring	1	
★ 14	Sheet packing	1	
★ 15	O-ring	2	See Remark 2.
16	Ball	1	
17	Hollow bolt	1	
18	Lock nut	1	
g41	Key	1	

Remark 1: The ★ indicates recommended spare parts. They are supplied as "Seat ring set".

Remark 2: The O-ring material (item number 15) should be the same as the sea ring (item number 12).

722F·720F Expanded View of Components

1000mm to 1350mm

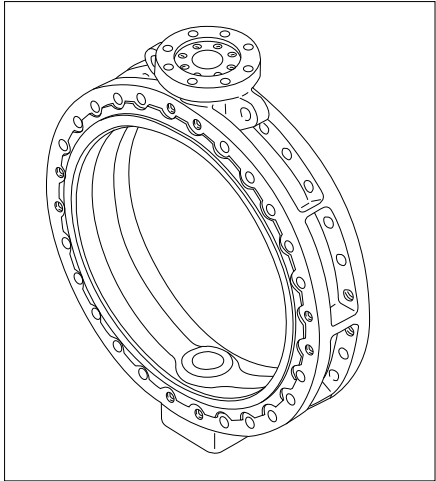

722F and 720F, 650mm to 1350mm

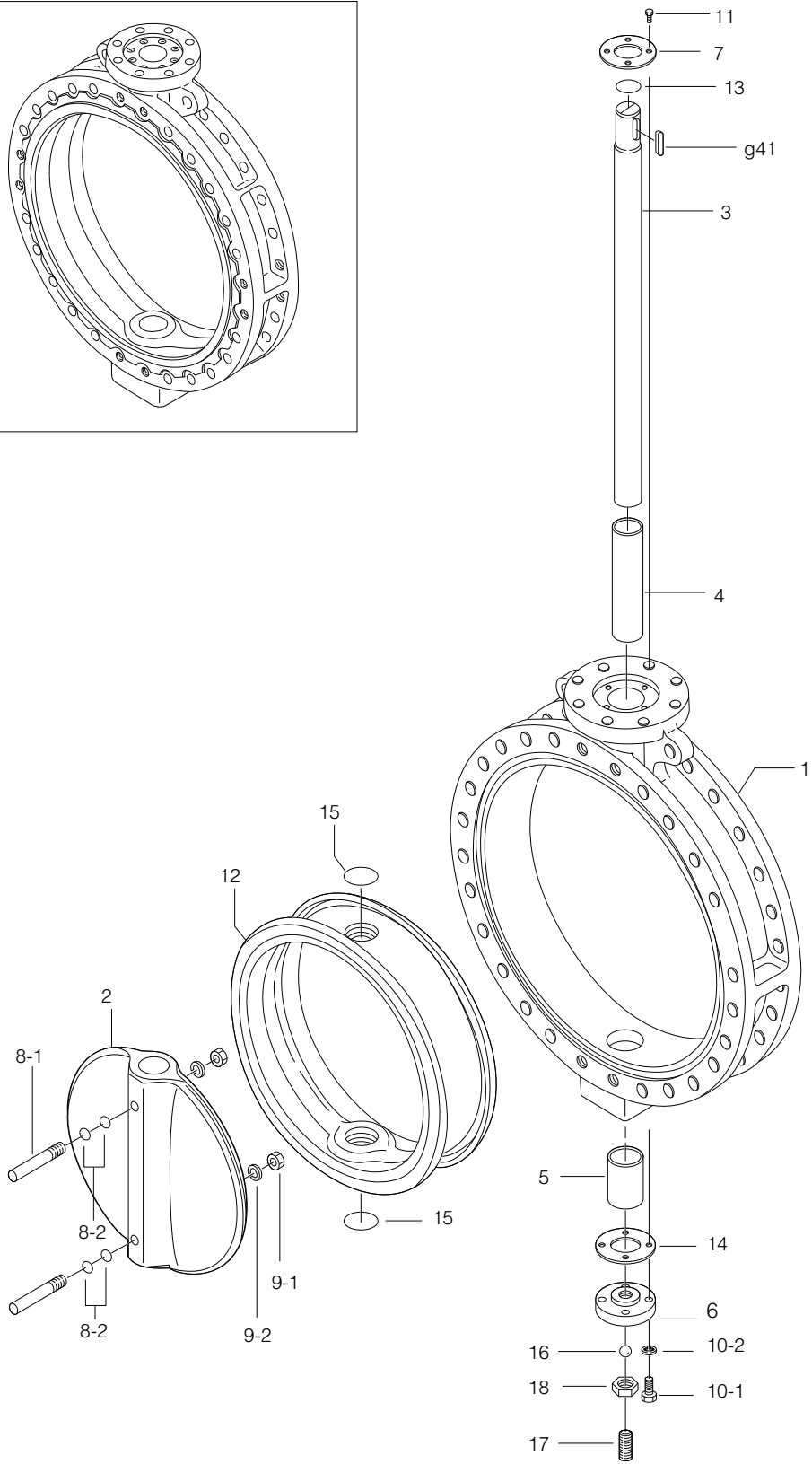

722F・720F Parts list

■ 722F and 720F Parts list (722F: 650mm to 800mm / 720F: 850mm to 1350mm)

No.	Description	Q'ty	Remarks
1	Body	1	
2	Disc	1	
3	Stem	1	
4	Bushing	1	
5	Bushing	1	
6	Bottom cover	1	
7	Retainer plate	1	
★ 8-1	Taper bolt	2	650mm to 900mm
		4	1000mm to 1350mm
★ 8-2	O-ring	4	650mm to 900mm
		8	1000mm to 1350mm
★ 9-1	Hexagon nut	2	650mm to 900mm
		4	1000mm to 1350mm
★ 9-2	Spring washer	2	650mm to 900mm
		4	1000mm to 1350mm
10-1	Hexagon bolt	4	650mm to 850mm
		8	900mm to 1350mm
10-2	Spring washer	4	650mm to 850mm
		8	900mm to 1350mm
11	Hexagon bolt	4	650mm to 850mm
		8	900mm to 1350mm
★ 12	Seat ring	1	1000mm to 1350mm:Vulcanized to the body
★ 13	O-ring	1	See Remark 2.
★ 14	Sheet packing	1	
★ 15	O-ring	2	See Remark 2.
16	Ball	1	
17	Hollow bolt	1	
18	Lock nut	1	
g41	Key	1	

Remark 1: The ★ indicates recommended spare parts. They are supplied as "Seat ring set".

Since the seat ring is vulcanized to the body of types 1000mm to 1350mm, please consult us if you wish to replace it.

Remark 2: The O-ring material (item numbers 13 and 15) should be the same as the seatring (item number 12).

704G Actuator Selection Chart

704G

Model	Category	Size <small>($\frac{mm}{inch}$)</small>			
		50	65	80	100
1T	Standard Heavy duty	1T-1			
2U	Standard Heavy duty	2U-0	2U-1		
2G	Standard Heavy duty	2G-1			
7E	Standard Heavy duty	T35	T85	T200	
7G,7F	Standard Heavy duty	T85S	T200S	T380S	
4 I	ON-OFF Control	4 I-00	4 I-0	4 I-1	
4J	Standard Heavy duty	SRJ-010			

Selection criteria	Standard	Select when none of the following heavy duty items apply.
	Heavy duty	Select when any of the following items apply. ① Powder or high viscosity fluid (crude oil, etc.), slurry ② Control specification (with positioner) ③ Emergency open valve or pipe dead end valve

704G/722F/720F Pressure-Temperature Rating

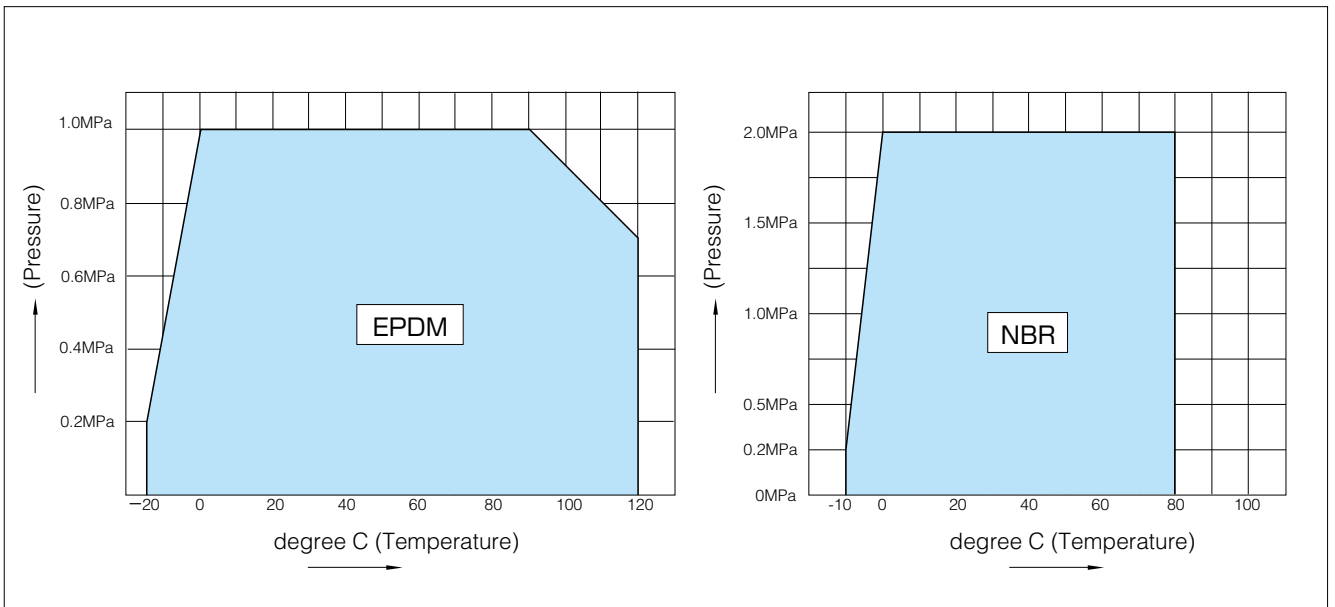

722F Actuator selection chart

722F

Model	Category	Size <small>($\frac{mm}{inch}$)</small>																
		125	150	200	250	300	350	400	450	500	550	600	650	700	750	800		
		5	6	8	10	12	14	16	18	20	22	24	26	28	30	32		
1T	Standard	1T-2		1T-3														
	Heavy duty	1T-2		1T-3														
2U,2S	Standard	2U-2		2U-3		2U-4		2U-5			2U-6		MGH-4	MGH-4 1/2				
	Heavy duty	2U-2		2U-3		2U-4		2U-5			2U-6		MGH-4	MGH-4 1/2				
2G,2R	Standard	2G-2		2G-3		2G-4		2R-3			2R-4							
	Heavy duty	2G-2		2G-3		2G-4		2R-3			2R-4							
7E,3A	Standard	T200		T380		T750		TGA-125		TGA-140		TGA-180		TGA-200		TGA-220		
	Heavy duty	T200		T380		T750		TGA-125		TGA-140		TGA-160		TGA-180		TGA-200		TGA-220
7G,7F 3U,3K	Standard	T380S		T750S		TG-10S		TG-12S			TG-14S		TG-20S					
	Heavy duty	T380S		T750S		TG-10S		TG-12S			TG-14S		TG-20S					
4I	ON-OFF	4I-2		4I-2.5		4I-3			4I-4									
	Control	4I-2		4I-2.5		4I-3			4I-4									
4J,4L	Standard	SRJ-020			SRJ-060			LTKD-01 0.2kW/MGH-3		LTKD-01 0.4kW/MGH-3		LTKD-02 0.75kW/MGH-4	LTKD-05 0.75kW/MGH-4		LTKD-05 0.75kW/MGH-5	LTKD-05 1.5kW/MGH-5	LTKD-1 1.5kW/MGH-5	
	Heavy duty	SRJ-020			SRJ-060			LTKD-01 0.2kW/MGH-3		LTKD-01 0.4kW/MGH-3		LTKD-02 0.75kW/MGH-4	LTKD-05 0.75kW/MGH-4		LTKD-05 0.75kW/MGH-5	LTKD-05 1.5kW/MGH-5	LTKD-1 1.5kW/MGH-5	

Remark: For the 400mm type with the accessories below, type 4I-4 should be selected.

- Micom unit
- Servo unit
- Speed control unit
- Potentiometer

Selection criteria	Standard	Select when none of the following heavy duty items apply.
	Heavy duty	Select when any of the following items apply. ① Powder or high viscosity fluid (crude oil, etc.), slurry ② Control specification (with positioner) ③ Emergency open valve or pipe dead end valve

720F Actuator selection chart

720F

Model	Category	Size <small>($\frac{mm}{inch}$)</small>						
		850	900	1000	1100	1200	1350	
		34	36	40	44	48	54	
2S	Standard	MGH-5			MGH-6		MGH-7	
	Heavy duty	MGH-5			MGH-6		MGH-7	
3A	Standard	TGA-220		TGA-250				
	Heavy duty	TGA-220		TGA-250				
4L	Standard	LTKD-1 1.5kW/MGH-5		LTKD-1 2.2kW/MGH-5		LTKD-1 1.5kW/MGH-6		LTKD-1 2.2kW/MGH-7
	Heavy duty	LTKD-1 1.5kW/MGH-5		LTKD-1 2.2kW/MGH-5		LTKD-1 1.5kW/MGH-6		LTKD-1 2.2kW/MGH-7

Selection criteria	Standard	Select when none of the following heavy duty items apply.
	Heavy duty	Select when any of the following items apply. ① Powder or high viscosity fluid (crude oil, etc.), slurry ② Control specification (with positioner) ③ Emergency open valve or pipe dead end valve

704G (Lugged) 722F (Double Flanged) / 720F (Double Flanged)

704G / 722F / 720F Dimension List

704G

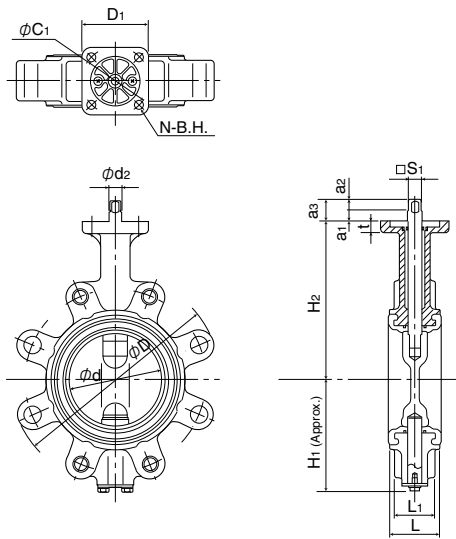

704G Dimensions

Nominal size		Dimension (mm)																Approx. Weight (kg)
mm	inch	φd	L	L ₁	φD	H ₁	H ₂	d ₂	a ₁	a ₂	a ₃	S ₁	D ₁	t	φC ₁	N	BH	
50	2	56	43	33	155	67	138	10	11	10.5	21.5	8	70	12	70	4	9	3.4
65	2 1/2	69	46	36	175	78	151	10	11	10.5	21.5	8	70	12	70	4	9	4.4
80	3	84	46	36	187	85(109)	156	12	11	11.5	22.5	10	70	12	70	4	9	5(5.5)
100	4	104	52	42	220	117	167	14	11	11.5	22.5	12	70	12	70	4	9	7.7

Remark: Value in brackets is for JIS 10K flanges.

722F

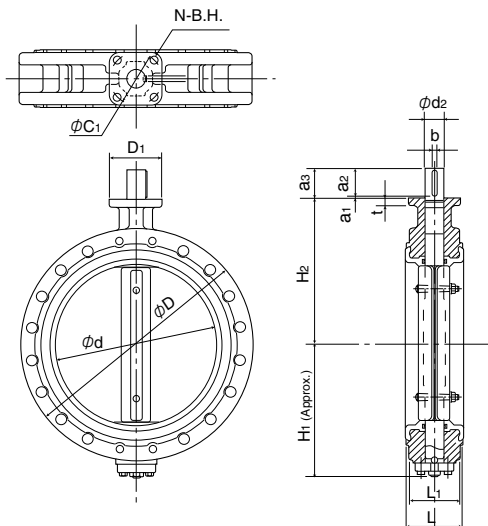

722F Dimensions

Nominal size		Dimension (mm)																Approx. Weight (kg)	
mm	inch	φd	L	L ₁	φD	H ₁	H ₂	φd ₂	a ₁	a ₂	a ₃	S ₁	b	D ₁	t	φC ₁	N		BH
125	5	129	100	—	250	139	165	18	11	16.5	27.5	14	—	102	14	102	4	11	18
150	6	154	100	—	280	157	180	18	11	16.5	27.5	14	—	102	14	102	4	11	19
200	8	194	100	—	330	181	210	22	10	20	30	18	—	102	14	102	4	11	37
250	10	250	110	—	400	221	250	30	5	30	35	24	—	102	14	102	4	11	43
300	12	296	110	—	445	251	280	32	5	30	35	24	—	125	16	125	4	13	52
350	14	334	120	110	490	298	320	40	6	45	54	—	12	140	20	140	4	19	70
400	16	384	130	116	560	334	360	46	6	56	65	—	14	140	20	140	4	19	93
450	18	435	150	134	620	356	390	50	6	70	79	—	14	140	20	140	4	19	132
500	20	482	160	140	675	382	420	50	6	70	79	—	14	140	25	140	4	19	182
550	22	531	170	156	745	418	460	55	6	70	79	—	16	165	25	165	4	23	225
600	24	581	170	156	795	476	490	55	6	70	79	—	16	165	25	165	4	23	270
650	26	627	170	150	845	586	510	65	10	60	75	—	18	260	32	220	4	23	415
700	28	670	180	160	905	629	560	75	10	80	95	—	20	320	35	280	8	23	585
750	30	723	190	170	970	659	590	75	10	80	95	—	20	320	35	280	8	23	680
800	32	772	200	180	1020	679	620	75	10	80	95	—	20	320	35	280	8	23	810

720F

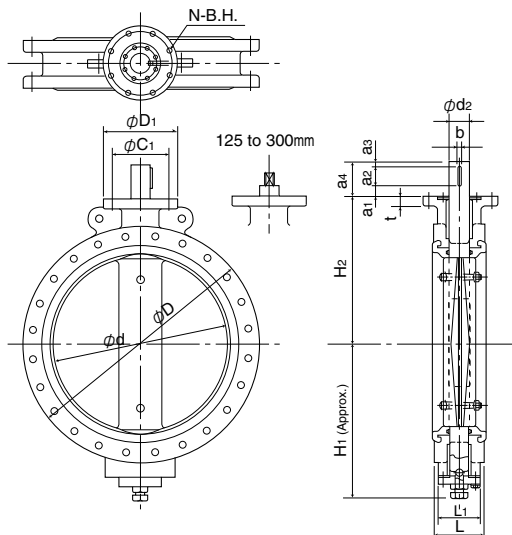

720F Dimensions

Nominal size		Dimension (mm)																Approx. Weight (kg)	
mm	inch	φd	L	L ₁	φD	H ₁	H ₂	φd ₂	a ₁	a ₂	a ₃	a ₄	b	φD ₁	t	φC ₁	N		BH
850	34	822	210	—	1070	709	650	75	10	80	5	95	20	320	40	280	8	23	※
900	36	858	230	—	1120	759	685	75	10	80	5	95	20	320	40	280	8	23	※
1000	40	975	250	210	1235	819	745	95	10	100	10	120	24	320	45	280	8	23	※
1100	44	1070	280	210	1345	874	820	95	10	100	10	120	24	320	45	280	8	23	※
1200	48	1170	300	225	1465	948	880	95	10	100	10	120	24	320	45	280	8	23	※
1350	54	1314	330	300	1630	1030	960	120	60	140	10	210	32	320	45	280	8	23	※

※Please consult us.

Lock lever type 704G-1T(50mm to 100mm) / 722F-1T(125mm to 200mm)

Type	Nominal size		Dimension (mm)							Lever type	Approx. Mass (kg)
	mm	inch	ϕd	ϕD	L	H ₁	H ₂	H ₃	W		
704G	50	2	56	155	43	67	138	66	200	1T-1	4
	65	2 1/2	69	175	46	78	151	66	200	1T-1	5
	80	3	84	187	46	85 (109)	156	66	200	1T-1	5.6 (6.1)
	100	4	104	220	52	117	167	66	200	1T-1	8.3
722F	125	5	129	250	100	139	165	92	300	1T-2	19.3
	150	6	154	280	100	157	180	92	300	1T-2	20.3
	200	8	194	330	100	181	210	97	350	1T-3	38.7

Remark: Value in brackets is for JIS 10K flanges.

704G / 722F-1T

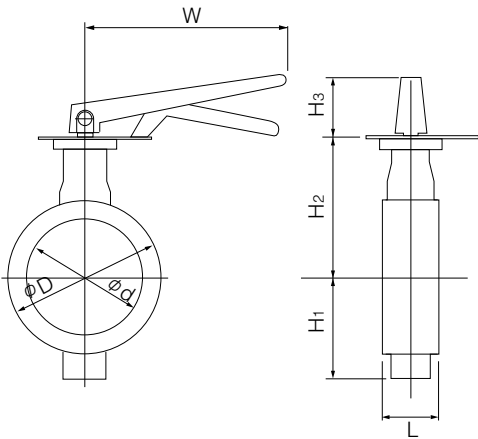

1T Installation direction

1T LS (standard)	1T LR	1T RS	1T RR
1T XS	1T XR	1T VS	1T VR

704G (Lugged) / 722F (Double Flanged) / 720F (Double Flanged)

Worm Gear Type 704G-2U (50mm to 100mm) / 722F-2U (125mm to 600mm) / 722F-2S (650mm to 800mm) / 720F-2S (850mm to 1350mm)

704G-2U (50mm to 100mm)

Type	Nominal size		Dimension (mm)										Gear type	Approx. Weight (kg)
	mm	inch	ϕd	ϕD	L	H ₁	H ₂	H ₃	E	K	F	ϕW		
704G	50	2	56	155	43	67	138	29.5	36	46	160	100	2U-0	5.7
	65	2 1/2	69	175	46	78	151	29.5	36	46	160	100	2U-0	6.7
	80	3	84	187	46	85 (109)	156	29.5	36	46	160	100	2U-1	7.3(7.8)
	100	4	104	220	52	117	167	29.5	36	46	160	100	2U-1	10

Remark: Value in brackets is for JIS 10K flanges.

722F-2U (125mm to 600mm) / 722F-2S (650mm to 800mm) / 720F-2S (850mm to 1350mm)

Type	Nominal size		Dimension (mm)											Gear type	Approx. Weight (kg)
	mm	inch	ϕd	ϕD	L	H ₁	H ₂	H ₃	E	K	G	F	ϕW		
722F	125	5	129	250	100	139	165	34.5	44	53	—	173.5	160	2U-2	22.2
	150	6	154	280	100	157	180	34.5	44	53	—	173.5	160	2U-2	23.2
	200	8	194	330	100	181	210	41.5	67	75	—	198	200	2U-3	45
	250	10	250	400	110	221	250	41.5	67	75	—	198	200	2U-3	51
	300	12	296	445	110	251	280	48	87.5	90	—	222.5	200	2U-4	66
	350	14	334	490	120	298	320	50	90	105	—	266	280	2U-5	84
	400	16	384	560	130	334	360	50	90	105	—	266	280	2U-5	107
	450	18	435	620	150	356	390	50	90	105	—	266	280	2U-5	146
	500	20	482	675	160	382	420	50	90	105	—	266	280	2U-5	196
	550	22	531	745	170	418	460	61	113	140	—	352	400	2U-6	256
	600	24	581	795	170	476	490	61	113	140	—	352	400	2U-6	301
	650	26	627	845	170	586	510	65	140	198	—	400	450	MGH-4	463
	700	28	670	905	180	629	560	75	185	267	—	457	500	MGH-4 1/2	692
	750	30	723	970	190	659	590	75	185	267	—	457	500	MGH-4 1/2	782
800	32	772	1020	200	679	620	75	185	267	—	457	500	MGH-4 1/2	907	
720F	850	34	822	1070	210	709	650	100	210	293	—	490	500	MGH-5	1050
	900	36	858	1120	230	759	685	100	210	293	—	490	500	MGH-5	1150
	1000	40	975	1235	250	819	745	100	210	293	350	490	500	MGH-6	1384
	1100	44	1070	1345	280	874	820	100	210	293	350	490	500	MGH-6	1584
	1200	48	1168	1465	300	949	880	100	210	293	350	490	500	MGH-6	1984
1350	54	1314	1630	330	1030	960	151	280	293	310	675	600	MGH-7	2436	

704G/722F/720F-2U/2S
(125mm to 900mm)

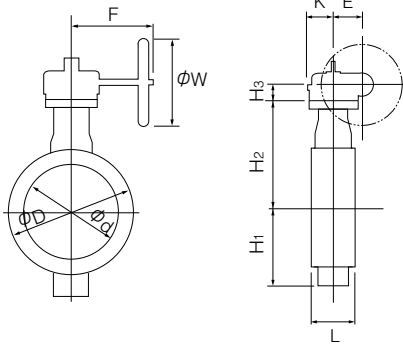

720F-2S
(1000mm to 1350mm)

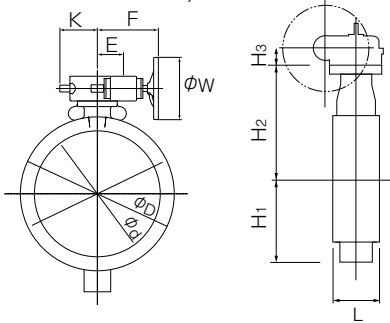

2U / 2S Installation Direction
(125mm to 900mm)

2UA/2SA(standard)	2UAR/2SAR	2UB/2SB	2UBR/2SBR

2S Installation Direction
(1000mm to 1350mm)

2SA(standard)	2SAR	2SB	2SBR

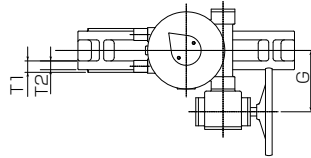

704G (Lugged) / 722F (Double Flanged) / 720F (Double Flanged)

Center handle type 704G-2G (50mm to 100mm) / 722F-2G (125mm to 300mm) / 722F-2R (350mm to 600mm)

704G-2G (50mm to 100mm)

Nominal size		Dimension (mm)							Center handle type	Approx. Mass (kg)
mm	inch	ϕd	ϕD	L	H ₁	H ₂	H ₃	ϕW		
50	2	56	155	43	67	138	136	100	2G-1	6.3
65	2 1/2	69	175	46	78	151	136	100	2G-1	7.3
80	3	84	187	46	85 (109)	156	136	100	2G-1	7.9(8.4)
100	4	104	220	52	117	167	136	100	2G-1	10.6

Remark: Value in brackets is for JIS 10K flanges.

722F-2G (125mm to 300mm) / 722F-2R (350mm to 600mm)

Nominal size		Dimension (mm)							Center handle type	Approx. Mass (kg)
mm	inch	ϕd	ϕD	L	H ₁	H ₂	H ₃	ϕW		
125	5	129	250	100	139	165	136	100	2G-2	22
150	6	154	280	100	157	180	136	100	2G-2	23
200	8	194	330	100	181	210	151	200	2G-3	45
250	10	250	400	110	221	250	151	200	2G-3	51
300	12	296	445	110	251	280	161	200	2G-4	60
350	14	334	490	120	298	320	409	355	2R-3	106
400	16	384	560	130	334	360	409	355	2R-3	128
450	18	435	620	150	356	390	409	355	2R-3	168
500	20	482	675	160	382	420	409	355	2R-3	218
550	22	531	745	170	418	460	498	450	2R-4	283
600	24	581	795	170	476	490	498	450	2R-4	328

704G / 722F-2G / 2R

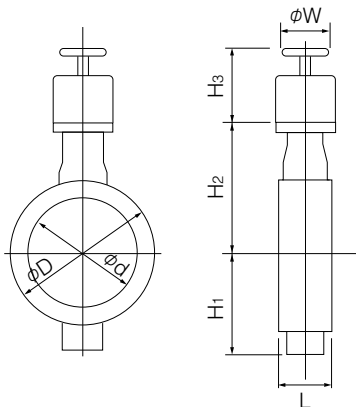

Double-acting Pneumatic Cylinder Type 704G-7E (50mm to 100mm) / 722F-7E (125mm to 350mm)

Standard

Type	Nominal size		Dimension (mm)										Cylinder type	Approx. Weight (kg)
	mm	inch	ϕd	ϕD	L	H ₁	H ₂	H ₃	A	P	f ₁	f ₂		
704G	50	2	56	155	43	67	138	125	228	116	57	29	T35	5
	65	2 1/2	69	175	46	78	151	125	228	116	57	29	T35	6
	80	3	84	187	46	85 (109)	156	168	276	142	75	47	T85	10 (11)
	100	4	104	220	52	117	167	168	276	142	75	47	T85	13
722F	125	5	129	250	100	139	165	203	346	176	79	57	T200	27
	150	6	154	280	100	157	180	203	346	176	79	57	T200	28
	200	8	194	330	100	181	210	203	346	176	79	57	T200	46
	250	10	250	400	110	221	250	231	423	214	91	69	T380	58
	300	12	296	445	110	251	280	269	546	270	118	85	T750	77
	350	14	334	490	120	298	320	269	546	270	118	85	T750	103

Remark: Value in brackets is for JIS 10K flanges.

Heavy duty

Type	Nominal size		Dimension (mm)										Cylinder type	Approx. Weight (kg)
	mm	inch	ϕd	ϕD	L	H ₁	H ₂	H ₃	A	P	f ₁	f ₂		
704G	50	2	56	155	43	67	138	125	228	116	57	29	T35	5
	65	2 1/2	69	175	46	78	151	125	228	116	57	29	T35	6
	80	3	84	187	46	85 (109)	156	168	276	142	75	47	T85	10 (11)
	100	4	104	220	52	117	167	203	346	176	79	57	T200	16
722F	125	5	129	250	100	139	165	203	346	176	79	57	T200	27
	150	6	154	280	100	157	180	203	346	176	79	57	T200	28
	200	8	194	330	100	181	210	231	423	214	91	69	T380	52
	250	10	250	400	110	221	250	269	546	270	118	85	T750	68
	300	12	296	445	110	251	280	269	546	270	118	85	T750	77

704G / 722F-7E

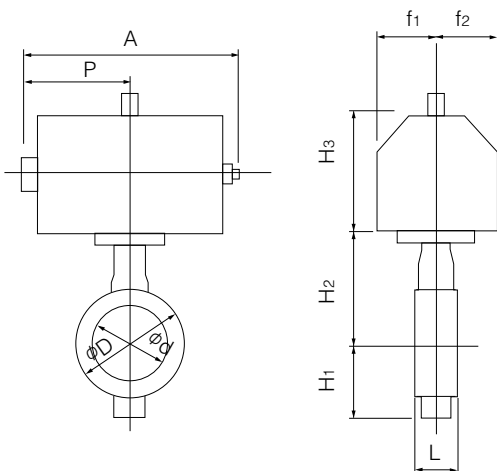

Selection criteria	Standard	Select when none of the following heavy duty items apply.
	Heavy duty	Select when any of the following items apply. ① Powder or high viscosity fluid (crude oil, etc.), slurry ② Control specification (with positioner) ③ Emergency open valve or pipe dead end valve

7E Installation Direction

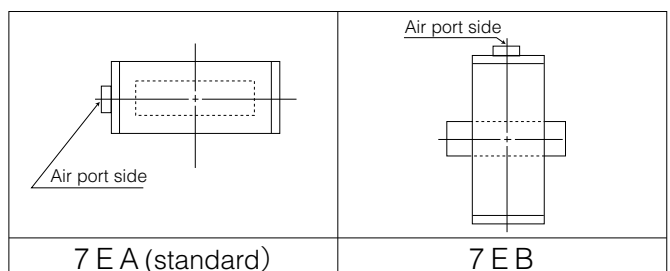

704G (Lugged) 722F (Double Flanged) / 720F (Double Flanged)

Double-acting pneumatic cylinder type 722F-3A (400mm to 800mm) / 720F-3A (850mm, 900mm)

Standard

Type	Nominal size		Dimension (mm)										Cylinder type	Approx. Mass (kg)
	mm	inch	ϕd	ϕD	L	H ₁	H ₂	H ₃	A	P	f ₁	f ₂		
722F	400	16	384	560	130	334	360	364	754	381	100	164	TGA-125	134
	450	18	435	620	150	356	390	437	840	432	100	180	TGA-140	192
	500	20	482	675	160	382	420	465	954	483	130	203	TGA-160	289
	550	22	531	745	170	418	460	465	954	483	130	203	TGA-160	339
	600	24	581	795	170	476	490	478	1069	543	130	221	TGA-180	408
	650	26	627	845	170	586	510	478	1069	543	130	221	TGA-180	566
	700	28	670	905	180	629	560	570	1175	599	160	254	TGA-200	812
	750	30	723	970	190	659	590	570	1175	599	160	254	TGA-200	907
720F	850	34	822	1070	210	709	650	600	1263	642	160	271	TGA-220	1151
	900	36	858	1120	230	759	685	633	1394	707	160	302	TGA-250	1317

Heavy duty

Type	Nominal size		Dimension (mm)										Cylinder type	Approx. Mass (kg)
	mm	inch	ϕd	ϕD	L	H ₁	H ₂	H ₃	A	P	f ₁	f ₂		
722F	350	14	334	490	120	298	320	364	754	381	100	164	TGA-125	111
	400	16	384	560	130	334	360	412	840	432	100	180	TGA-140	147
	450	18	435	620	150	356	390	465	954	483	130	203	TGA-160	239
	500	20	482	675	160	382	420	465	954	483	130	203	TGA-160	289
	550	22	531	745	170	418	460	478	1069	543	130	221	TGA-180	363
	600	24	581	795	170	476	490	525	1175	599	160	254	TGA-200	464
	650	26	627	845	170	586	510	600	1263	642	160	271	TGA-220	672
	700	28	670	905	180	629	560	600	1263	642	160	271	TGA-220	842
	750	30	723	970	190	659	590	633	1394	707	160	302	TGA-250	996
800	32	772	1020	200	679	620	633	1394	707	160	302	TGA-250	1126	

722F / 720F-3A

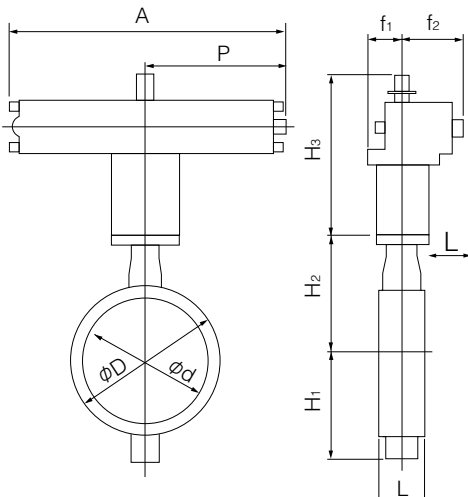

Selection criteria	Standard	Select when none of the following heavy duty items apply.
	Heavy duty	Select when any of the following items apply. ① Powder or high viscosity fluid (crude oil, etc.), slurry ② Control specification (with positioner) ③ Emergency open valve or pipe dead end valve

3A Installation direction

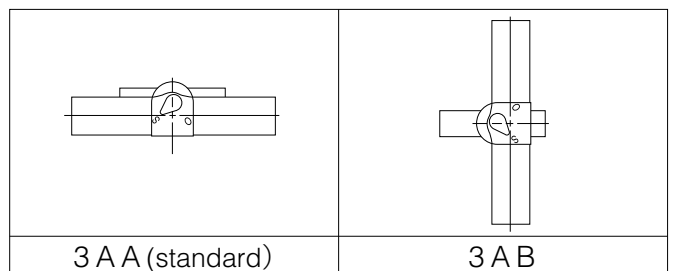

Single-acting Pneumatic Cylinder Type 704G-7G (Air to open: 50mm to 100mm) / 722F-7G (Air to open: 125mm to 200mm)
 704G-7F (Air to close: 50mm to 100mm) / 722F-7F (Air to close: 125mm to 200mm)

■ Standard

Type	Nominal size		Dimension (mm)										Cylinder type	Approx. Weight (kg)
	mm	inch	ϕd	ϕD	L	H ₁	H ₂	H ₃	A	P	f ₁	f ₂		
704G	50	2	56	155	43	67	138	168	364	183	75	47	T85S	10
	65	2 1/2	69	175	46	78	151	203	449	226	79	57	T200S	16
	80	3	84	187	46	85 (109)	156	203	449	226	79	57	T200S	16 (17)
	100	4	104	220	52	117	167	203	449	226	79	57	T200S	19
722F	125	5	129	250	100	139	165	231	550	276	91	69	T380S	38
	150	6	154	280	100	157	180	231	550	276	91	69	T380S	39
	200	8	194	330	100	181	210	269	723	360	118	85	T750S	70

Remark: Value in brackets is for JIS 10K flanges.

■ Heavy Duty

Type	Nominal size		Dimension (mm)										Cylinder type	Approx. Weight (kg)
	mm	inch	ϕd	ϕD	L	H ₁	H ₂	H ₃	A	P	f ₁	f ₂		
704G	50	2	56	155	43	67	138	168	364	183	75	47	T85S	10
	65	2 1/2	69	175	46	78	151	203	449	226	79	57	T200S	16
	80	3	84	187	46	85 (109)	156	203	449	226	79	57	T200S	16 (17)
	100	4	104	220	52	117	167	231	550	276	91	69	T380S	27
722F	125	5	129	250	100	139	165	231	550	276	91	69	T380S	38
	150	6	154	280	100	157	180	231	550	276	91	69	T380S	39
	200	8	194	330	100	181	210	269	723	360	118	85	T750S	70

Remark: Value in brackets is for JIS 10K flanges.

Selection criteria	Standard	Select when none of the following heavy duty items apply.
	Heavy duty	Select when any of the following items apply. ① Powder or high viscosity fluid (crude oil, etc.), slurry ② Control specification (with positioner) ③ Emergency open valve or pipe dead end valve

■ 704G / 722F-7G / 7F

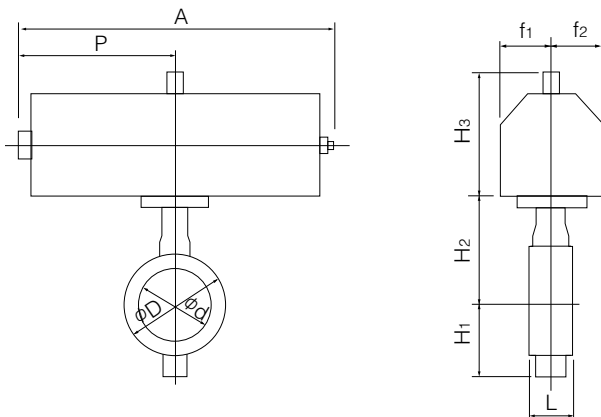

■ 7F Installation Direction

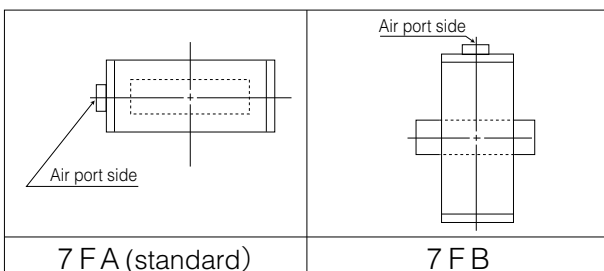

■ 7G Installation Direction

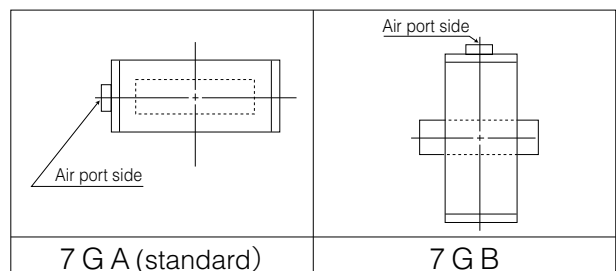

704G (Lugged) 722F (Double Flanged) / 720F (Double Flanged)

Single-acting pneumatic cylinder type 722F-3U (Air to open: 200mm to 600mm) / 722F-3K (Air to close: 200mm to 600mm)

Standard

Nominal size		Dimension (mm)										Cylinder type	Approx. Mass (kg)
mm	inch	ϕd	ϕD	L	H ₁	H ₂	H ₃	A	P	f ₁	f ₂		
250	10	250	400	110	221	250	307	945	585	70	165	TG-10S	99
300	12	296	445	110	251	280	307	1080	720	94	206	TG-12S	153
350	14	334	490	120	298	320	307	1080	720	94	206	TG-12S	171
400	16	384	560	130	334	360	340	1255	865	131	257	TG-14S	291
450	18	435	620	150	356	390	340	1255	865	131	257	TG-14S	330
500	20	482	675	160	382	420	474	1655	1095	164	348	TG-20S	593
550	22	531	745	170	418	460	474	1655	1095	164	348	TG-20S	636
600	24	581	795	170	476	490	474	1655	1095	164	348	TG-20S	681

Heavy duty

Nominal size		Dimension (mm)										Cylinder type	Approx. Mass (kg)
mm	inch	ϕd	ϕD	L	H ₁	H ₂	H ₃	A	P	f ₁	f ₂		
200	8	194	330	100	181	210	307	945	585	70	165	TG-10S	93
250	10	250	400	110	221	250	307	1080	720	94	206	TG-12S	144
300	12	296	445	110	251	280	307	1080	720	94	206	TG-12S	153
350	14	334	490	120	298	320	340	1255	865	131	257	TG-14S	267
400	16	384	560	130	334	360	340	1255	865	131	257	TG-14S	291
450	18	435	620	150	356	390	474	1655	1095	164	348	TG-20S	543
500	20	482	675	160	382	420	474	1655	1095	164	348	TG-20S	593
550	22	531	745	170	418	460	474	1655	1095	164	348	TG-20S	636
600	24	581	795	170	476	490	474	1655	1095	164	348	TG-20S	681

722F-3U

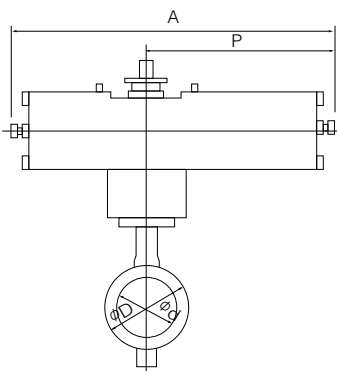

722F-3K

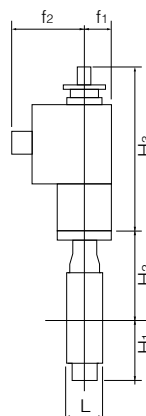
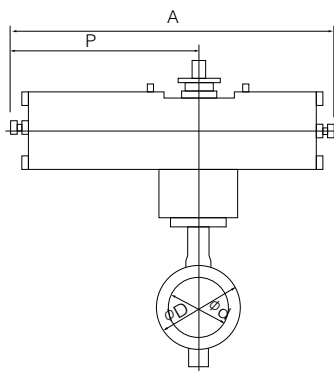

Selection criteria	Standard	Select when none of the following heavy duty items apply.
	Heavy duty	Select when any of the following items apply. ① Powder or high viscosity fluid (crude oil, etc.), slurry ② Control specification (with positioner) ③ Emergency open valve or pipe dead end valve

3U Installation direction

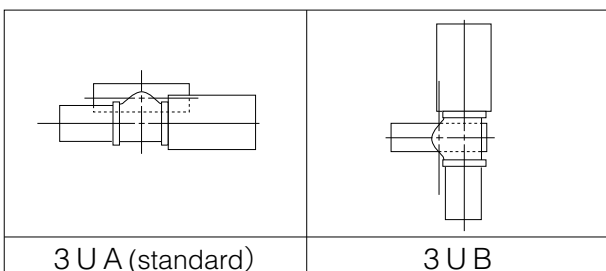

3K Installation direction

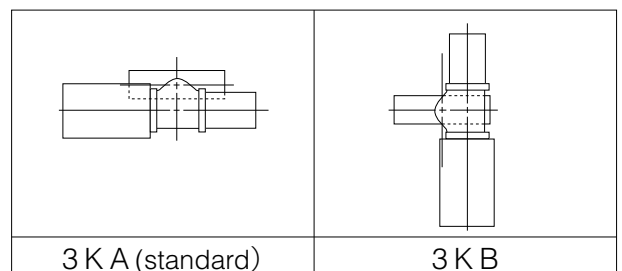

Single Phase Motor Type 704G-4 I (50mm to 100mm) / 722F-4 I (125mm to 500mm)

704G-4 I

Nominal size		Dimension (mm)										Motor type	Approx. Weight (kg)
mm	inch	ϕd	ϕD	L	H ₁	H ₂	H ₃	A	P	F	K		
50	2	56	155	43	67	138	121	161	84	58	45	4 I-00	5.9
							150	202	100	85	54	4 I-0	7.6
65	2 1/2	69	175	46	78	151	150	202	100	85	54	4 I-0	8.6
80	3	84	187	46	85 (109)	156	150	202	100	85	54	4 I-0	9.2(11.9)
100	4	104	220	52	117	167	165	252	138	126	65	4 I-1	14.1

Remark: Value in brackets is for JIS 10K flanges.

722F-4 I

Nominal size		Dimension (mm)										Motor type	Approx. Weight (kg)
mm	inch	ϕd	ϕD	L	H ₁	H ₂	H ₃	A	P	F	K		
125	5	129	250	100	139	165	198	310	167	154	85	4 I-2	30
150	6	154	280	100	157	180	198	310	167	154	85	4 I-2	31
200	8	194	330	100	181	210	198	310	167	154	85	4 I-2.5	51
250	10	250	400	110	221	250	230	388	223	246	136	4 I-3	67
300	12	296	445	110	251	280	230	388	223	246	136	4 I-3	76
350	14	334	490	120	298	320	230	388	223	246	136	4 I-3	93
400	16	384	560	130	334	360	230	388	223	246	136	4 I-3	116
							255	388	223	246	136	4 I-4	122
450	18	435	620	150	356	390	230	388	223	246	136	4 I-4	161
500	20	482	675	160	382	420	230	388	223	246	136	4 I-4	211

Remark: For the 400mm type with the accessories below, type 4I-4 should be selected.

- Micom unit
- Servo unit
- Speed control unit
- Potentiometer

Selection criteria	Standard	Select when none of the following heavy duty items apply.
	Heavy duty	Select when any of the following items apply. ① Powder or high viscosity fluid (crude oil, etc.), slurry ② Control specification (with positioner) ③ Emergency open valve or pipe dead end valve

704G / 722F-4 I

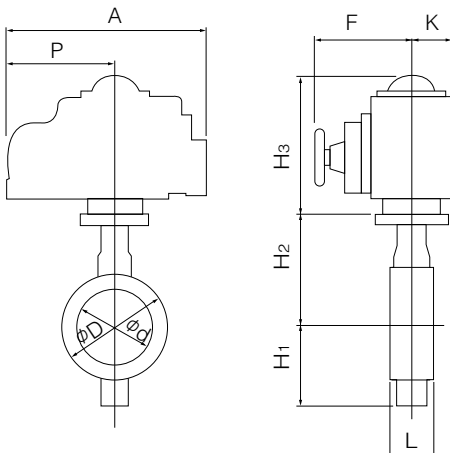

4 I Installation Direction

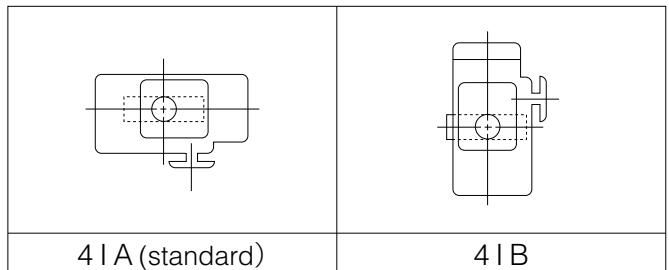

704G (Lugged) 722F (Double Flanged) / 720F (Double Flanged)

Three phase motor actuator type 704G-4J (50mm to 100mm)

704G-4J

Nominal size		Dimension (mm)											Motor type	Approx. Mass (kg)
mm	inch	ϕd	ϕD	L	H ₁	H ₂	H ₃	H ₄	A	P	F	K		
50	2	56	155	43	67	138	218	3.2	353	167	272	104	SRJ-010	17.1
65	2 1/2	69	175	46	78	151	218	3.2	353	167	272	104	SRJ-010	18.1
80	3	84	187	46	85 (109)	156	218	3.2	353	167	272	104	SRJ-010	18.7(19.2)
100	4	104	220	52	117	167	218	3.2	353	167	272	104	SRJ-010	21.2

Remark: Value in brackets is for JIS 10K flanges.

704G-4J

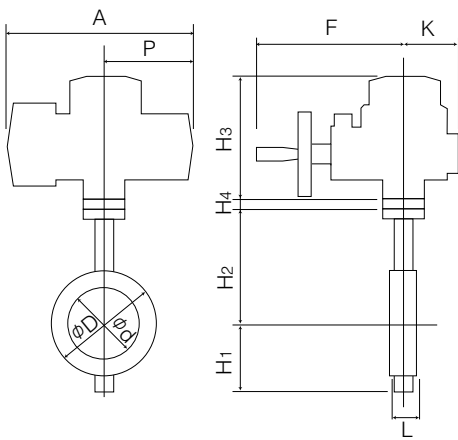

4J Installation direction

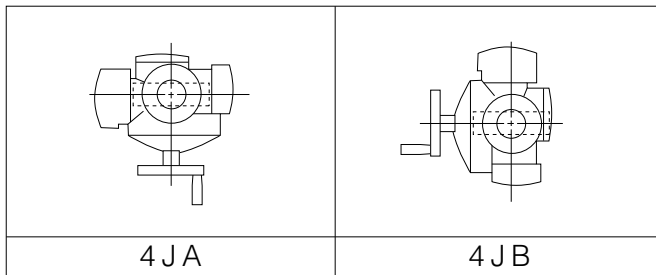

Three Phase Motor Actuator Type 722F-4L (350mm to 800mm) / 720F-4L (850mm to 1350mm)

Type	Nominal size		Dimension (mm)											Cylinder type	Approx. Weight (kg)	
	mm	inch	ϕd	ϕD	L	H ₁	H ₂	H ₃	E	G	K	F	M			P
722F	350	14	334	490	120	298	320	488	117	—	164	533	364	230	LTKD-01 0.2kW/MGH-3	213
	400	16	384	560	130	334	360	488	117	—	164	533	364	230	LTKD-01 0.2kW/MGH-3	230
	450	18	435	620	150	356	390	488	117	—	164	533	357	230	LTKD-01 0.4kW/MGH-3	268
	500	20	482	675	160	382	420	488	117	—	164	533	357	230	LTKD-01 0.4kW/MGH-3	303
	550	22	531	745	170	418	460	558	140	—	198	592	375	230	LTKD-02 0.75kW/MGH-4	411
	600	24	581	795	170	476	490	590	140	—	198	638	415	360	LTKD-05 0.75kW/MGH-4	500
	650	26	627	845	170	586	510	569	140	—	198	638	415	360	LTKD-05 0.75kW/MGH-4	600
	700	28	670	905	180	629	560	639	210	—	293	748	415	360	LTKD-05 0.75kW/MGH-5	885
	750	30	723	970	190	659	590	639	210	—	293	748	443	360	LTKD-05 1.5kW/MGH-5	980
	800	32	772	1020	200	679	620	679	210	—	293	799	503	410	LTKD-1 1.5kW/MGH-5	1180
720F	850	34	822	1070	210	709	650	680	210	—	293	799	503	410	LTKD-1 1.5kW/MGH-5	1192
	900	36	858	1120	230	759	685	680	210	—	293	799	524	410	LTKD-1 2.2kW/MGH-5	1269
	1000	40	975	1235	250	819	745	699	—	350	293	972	503	410	LTKD-1 1.5kW/MGH-6	1670
	1100	44	1070	1345	280	874	820	699	—	350	293	972	503	410	LTKD-1 1.5kW/MGH-6	1870
	1200	48	1170	1465	300	948	880	699	—	350	293	972	503	410	LTKD-1 1.5kW/MGH-6	2270
	1350	54	1314	1630	330	1030	960	699	—	310	293	1090	524	410	LTKD-1 2.2kW/MGH-7	2650

722F/720F-4L (350mm to 600mm)

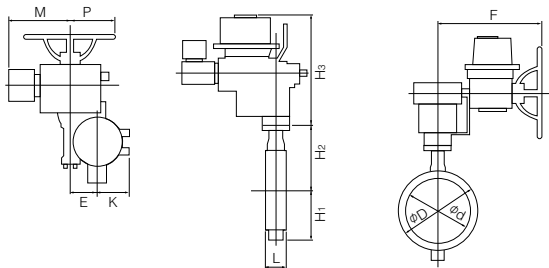

4L Installation Direction (350mm to 600mm)

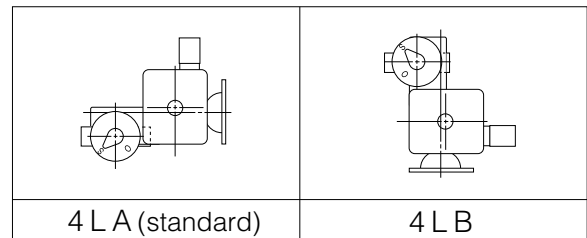

722F/720F-4L (650mm to 900mm)

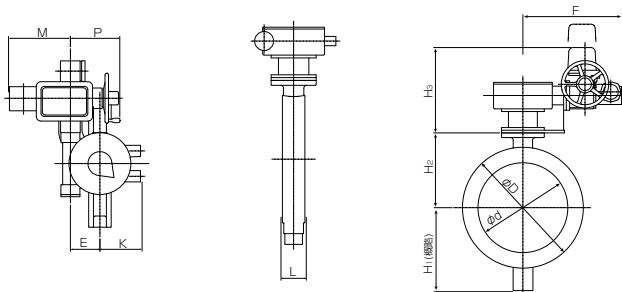

4L Installation Direction (650mm to 900mm)

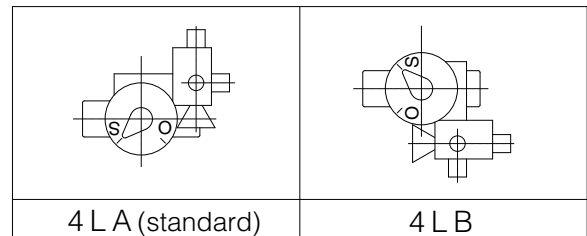

722F/720F-4L (1000mm to 1350mm)

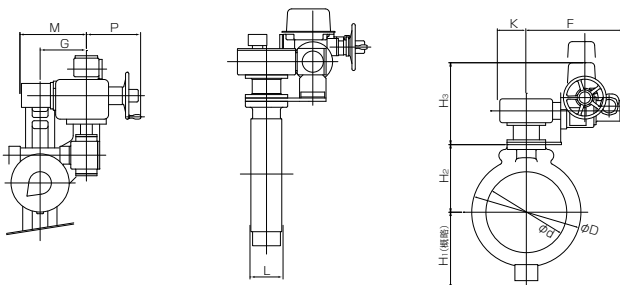

4L Installation Direction (1000mm to 1350mm)

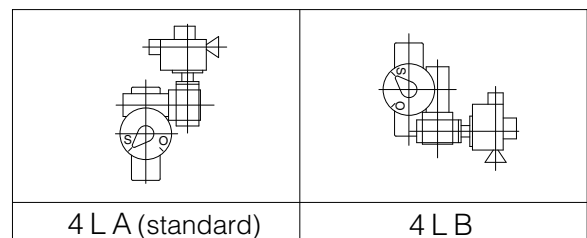

704G (Lugged) 722F (Double Flanged) / 720F (Double Flanged)

704G / 722F / 720F Cv value / Pressure loss coefficient

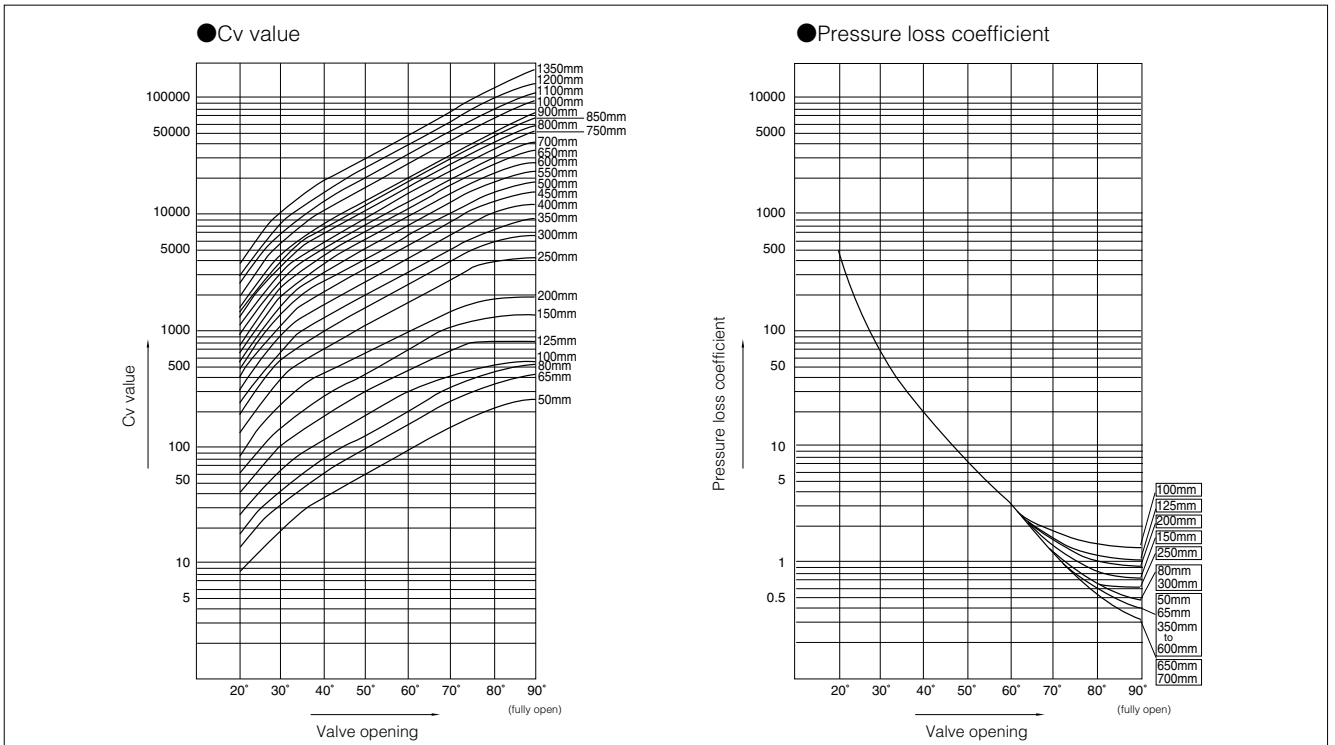

704G / 722F / 720F Cv value

Nominal size	Nominal size		Valve opening							
	mm	inch	20°	30°	40°	50°	60°	70°	80°	90°
704G	50	2	8	15	25	40	64	103	160	200
	65	2 1/2	12	25	41	64	102	162	260	320
	80	3	15	33	57	95	163	271	450	580
	100	4	27	58	100	162	269	444	749	880
722F	125	5	40	102	180	297	457	692	767	800
	150	6	61	146	272	429	710	1039	1295	1350
	200	8	71	239	417	646	969	1457	1836	1950
	250	10	139	375	693	1135	1746	2724	3855	4200
	300	12	184	544	995	1593	2461	3909	5571	6400
	350	14	215	678	1248	1982	3028	4827	7054	9000
	400	16	304	905	1656	2649	4094	6460	9782	12000
	450	18	381	1158	2136	3433	5274	8120	12430	15000
	500	20	496	1440	2631	4209	6434	10085	15436	17500
	550	22	571	1765	3234	5141	7833	12066	17999	22500
	600	24	688	2074	3815	6126	9433	14595	21897	26500
	650	26	817	2441	4473	7159	11013	17254	26972	32500
	700	28	934	2807	5122	8152	12511	19728	30929	39000
750	30	935	3220	5965	9450	14328	22687	38260	52000	
800	32	1200	3721	6791	10771	16553	26976	43316	59000	
720F	850	34	1164	4018	7516	12063	18567	29284	46350	66000
	900	36	1358	4497	8298	13177	20139	32362	53126	73000
	1000	40	1784	5835	10740	17060	26110	42070	68860	95000
	1100	44	2075	7030	13020	20680	31530	50420	83340	114000
	1200	48	2570	8520	15710	24900	37930	60280	98640	138000
1350	54	3385	10180	18810	30490	47840	75750	119000	173000	

704G / 722F / 720F Pressure Loss Coefficient

Nominal size	Nominal size		Valve opening							
	mm	inch	20°	30°	40°	50°	60°	70°	80°	90°
704G	50	2	257	68	25	10	4	2	1	0.4
	65	2 1/2	310	75	28	11	4	2	1	0.4
	80	3	394	83	27	10	3	1	0.4	0.2
	100	4	350	78	26	10	4	1	0.4	0.3
722F	125	5	399	61	19	7	3	1	1	1
	150	6	336	58	17	7	2	1	1	1
	200	8	745	65	22	9	4	2	1	1
	250	10	464	63	19	7	3	1	1	1
	300	12	545	62	19	7	3	1	1	0.4
	350	14	615	62	18	7	3	1	1	0.3
	400	16	540	61	18	7	3	1	1	0.3
	450	18	560	61	18	7	3	1	1	0.3
	500	20	510	61	18	7	3	1	1	0.4
	550	22	571	60	18	7	3	1	1	0.3
	600	24	561	62	18	7	3	1	1	0.3
	650	26	553	62	18	7	3	1	1	0.4
	700	28	573	63	19	8	3	1	1	0.3
	750	30	758	64	19	7	3	1	0.5	0.3
800	32	599	62	19	7	3	1	0.5	0.3	
720F	850	34	815	68	20	8	3	1	0.5	0.3
	900	36	756	69	20	8	3	1	0.5	0.3
	1000	40	645	60	18	7	3	1	0.4	0.2
	1100	44	701	61	18	7	3	1	0.4	0.2
	1200	48	658	60	18	7	3	1	0.4	0.2
	1350	54	611	68	20	8	3	1	0.5	0.2

704G (Lugged) 722F (Double Flanged) / 720F (Double Flanged)

704G / 722F / 720F Flange accommodation

Type	Nominal size		JIS		ASME		BS4504 PN10	DIN NP10
	mm	inch	5K	10K	class 125	class 150		
704G	50	2	○	○	○	○	○	○
	65	2 1/2	○	○	○	○	○	○
	80	3	◎	○	◎	◎	○	○
	100	4	○	○	○	○	○	○
722F	125	5	○	○	◎	◎		
	150	6	○	○	◎	◎		
	200	8	○	○	◎	◎		
	250	10	○	○	◎	◎		
	300	12	○	○	◎	◎		
	350	14	○	○	◎	◎		
	400	16	○	○	◎	◎		
	450	18	○	○	◎	◎		
	500	20	○	○	◎	◎		
	550	22	○	○	—	—		
	600	24	○	○	◎	◎		
	650	26	○	○	Consult us if the flange standard is not JIS 5K/10K in 650mm type and over.			
	700	28	○	○				
	750	30	○	○				
800	32	○	○					
850	34	○	○					
900	36	○	○					
720F	1000	40	○	○				
	1100	44	○	○				
	1200	48	○	○				
	1350	54	○	○				

○ : Can be used without flange drilling.
 ◎ : Tapped holes only. (ASME body only)

704G / 722F / 720F Applicable Pipe List in Case of **A**

Type	Nominal size		SGP	STPY	Sch20	Sch40	Sch10S	Sch20S	Minimum internal diameter of piping (mm)
	mm	inch							
704G	50	2	○	—	○	○	○	○	38
	65	2 1/2	○	—	○	○	○	○	54
	80	3	○	—	○	○	○	○	72
	100	4	○	—	○	○	○	○	92
722F	125	5	○	—	○	○	○	○	85
	150	6	○	—	○	○	○	○	121
	200	8	○	—	○	○	○	○	173
	250	10	○	—	○	○	○	○	230
	300	12	○	—	○	○	○	○	281
	350	14	○	○	○	○	—	—	317
	400	16	○	○	○	○	—	—	368
	450	18	○	○	○	○	—	—	414
	500	20	○	○	○	○	—	—	459
	550	22	—	○	○	○	—	—	505
	600	24	—	○	○	○	—	—	559
	650	26	—	○	○	○	—	—	612
	700	28	—	○	—	—	—	—	653
	750	30	—	○	—	—	—	—	705
720F	800	32	—	○	—	—	—	—	754
	850	34	—	○	—	—	—	—	803
	900	36	—	○	—	—	—	—	834
	1000	40	—	○	—	—	—	—	950
	1100	44	—	○	—	—	—	—	1040
	1200	48	—	○	—	—	—	—	1138
	1350	54	—	○	—	—	—	1277	

Remark 1: ○=Applicable

Remark 2: Butterfly valves are inserted into a pipe that was fitted with the disc when fully open.

In cases where you are using a pipe or flange that is less than the minimum inner pipe diameter, use is still possible if means are taken such as inserting a spacer between the valve and flange. For details, please consult us.

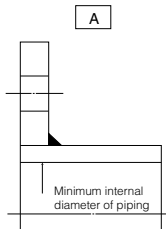

704G (Lugged) 722F (Double Flanged) / 720F (Double Flanged)

704G / 722F / 720F Applicable pipe list in case of **B**

Type	Nominal size		SGP	STPY	Sch20	Sch40	Sch10S	Sch20S
	mm	inch						
704G	50	2	○	—	○	○	○	○
	65	2 1/2	○	—	○	○	○	○
	80	3	○	—	○	○	○	○
	100	4	○	—	○	○	○	○
722F	125	5	○	—	○	○	○	○
	150	6	○	—	○	○	○	○
	200	8	○	—	○	○	○	○
	250	10	○	—	○	○	○	○
	300	12	○	—	○	○	○	○
	350	14	○	○	○	○	—	—
	400	16	○	○	○	○	—	—
	450	18	○	○	○	○	—	—
	500	20	○	○	○	○	—	—
	550	22	—	○	○	○	—	—
	600	24	—	○	○	○	—	—
	650	26	—	○	○	○	—	—
	700	28	—	○	—	—	—	—
	750	30	—	○	—	—	—	—
800	32	—	○	—	—	—	—	
720F	850	34	—	○	—	—	—	—
	900	36	—	○	—	—	—	—
	1000	40	—	○	—	—	—	—
	1100	44	—	○	—	—	—	—
	1200	48	—	○	—	—	—	—
	1350	54	—	○	—	—	—	—

Remark 1: ○=Applicable

Remark 2: Butterfly valves are inserted into a pipe that was fitted with the disc when fully open.

In cases where you are using a pipe or flange that is less than the minimum inner pipe diameter, use is still possible if means are taken such as inserting a spacer between the valve and flange. For details, please consult us.

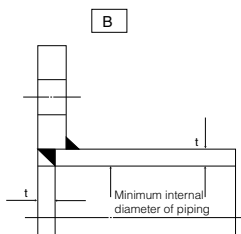

704G / 722F / 720F Piping Bolts Sizes

Type	Nominal size		JIS 5K		JIS 10K	
	mm	inch	Hexagon Bolts and Nuts	Hexagon Bolts	Hexagon Bolts and Nuts	Hexagon Bolts
704G	50	2	—	8-M12×30×25	—	8-M16×35×30
	65	2 1/2	—	8-M12×35×30	—	8-M16×35×30
	80	3	—	8-M16×35×30	—	16-M16×35×30
	100	4	—	16-M16×40×35	—	16-M16×40×35
722F	125	5	8-M16×60×38	8-M16×40×35	8-M20×65×46	8-M20×45×37
	150	6	8-M16×60×38	8-M16×40×35	8-M20×70×46	8-M20×50×42
	200	8	8-M20×65×46	8-M20×50×42	16-M20×70×46	8-M20×50×42
	250	10	16-M20×70×46	8-M20×50×42	16-M22×75×50	8-M22×50×42
	300	12	16-M20×70×46	8-M20×50×42	24-M22×75×50	8-M22×50×42
	350	14	16-M22×80×50	8-M22×55×47	24-M22×80×50	8-M22×55×47
	400	16	24-M22×85×50	8-M22×55×47	24-M24×90×54	8-M24×60×50
	450	18	24-M22×90×50	8-M22×60×50	32-M24×100×54	8-M24×65×54
	500	20	32-M22×90×50	8-M22×60×50	32-M24×100×54	8-M24×70×54
	550	22	32-M24×100×54	8-M24×65×54	32-M30×110×66	8-M30×70×54
	600	24	32-M24×100×54	8-M24×65×54	40-M30×110×66	8-M30×70×54
	650	26	40-M24×100×54	8-M24×70×54	40-M30×110×66	8-M30×80×66
	700	28	40-M24×100×54	8-M24×70×54	40-M30×110×66	8-M30×80×66
	750	30	40-M30×110×66	8-M30×80×66	40-M30×115×66	8-M30×80×66
720F	850	34	40-M30×110×66	8-M30×80×66	48-M30×115×66	8-M30×80×66
	900	36	32-M30×115×66	16-M30×75×66	40-M30×120×66	16-M30×80×66
	1000	40	40-M30×130×72	16-M30×90×66	40-M36×145×84	16-M36×110×78
	1100	44	40-M30×130×72	16-M30×90×66	40-M36×145×84	16-M36×110×78
	1200	48	48-M30×130×72	16-M30×90×66	48-M36×150×84	16-M36×110×78
	1350	54	56-M30×135×72	16-M30×90×66	56-M42×165×96	16-M42×110×90

Remarks:

1. The bolt for valve positioning uses the screw hole.
2. The hexagon bolt is used in the screw hole part for valve positioning.
3. Please use a hexagon nut with 80% threading.
4. For uses other than marine, use SS400 as the bolt (and nut) material.

Example

Hexagon bolts: 4 - M30 × 95 × 65

Hexagon bolts

