

304YA Wafer

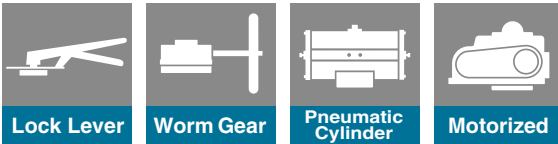
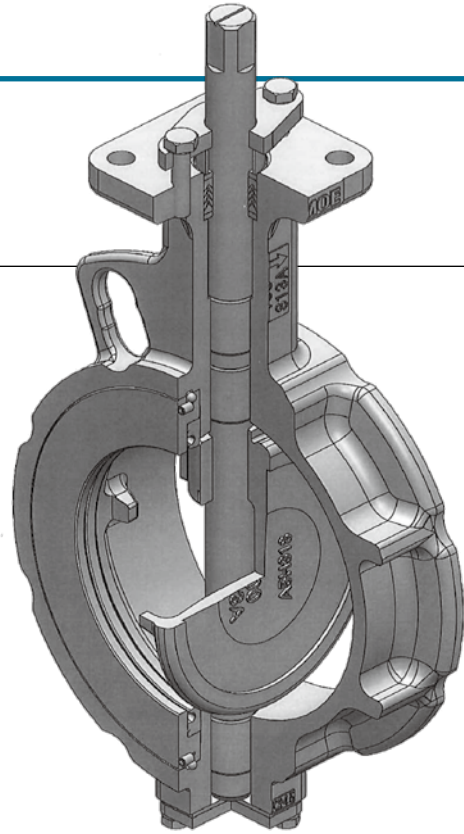

Features and Benefits

Weight saving

30% weight saving with suitable design of 1.0MPa
(compared with existing 304Y 300mm)

Self aligning disc design

Contact area of the body and the disc is spherical.
These spherical centers are displaced. When valve position is fully close, these surfaces are attached. When valve position is fully open, there is a clearance between the body and the disc. It can get both of smooth rotation and seal performance.

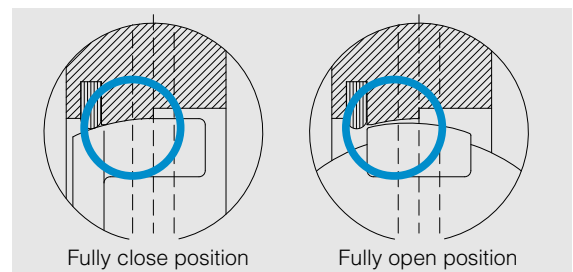

Applicable for hot/cold water supply

Low temperature range expansion

Change from -20 degrees C to -29 degrees C

Easy replacement of the seat ring

The ball lock method is used to simplify replacement of the seat ring.

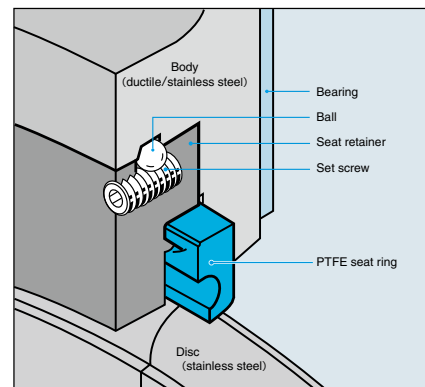

Standard Specifications

Valve Model		304YA	
Valve type		Double eccentric (Water)	
Valve nominal size		40, 50, 65, 80, 100, 125, 150, 200, 250, 300mm 1 1/2, 2, 2 1/2, 3, 4, 5, 6, 8, 10, 12inch	
Max. allowable working pressure		1.0MPa	
Allowable seat leakage		ISO 5208 leakage A (Tight shut off)	
Flow direction		Bi-directional Standard direction of pressurization : Retainer side Maximum pressure on shaft side (200mm to 300mm) : 0.6MPa	
Applicable standards	Face to face dimensions	JIS B 2002 (Series46) / ISO 5752 (Series20)	
	Flange accommodation	JIS 5K / 10K / ASME Class 150	
	Top flange	In compliance with ISO 5211	
Standard Materials ^{※1}	Body	FCD450	SCS13A
	Disc	SCS13A	
	Shaft	SUS420J2	SUS630 (H1150)
	Seating	RPTFE (Carbon and graphite contained)	
	Seating retainer	SF490A ^{※2} or S25C or S45C	SCS13A ^{※2} or SUS304
	Shaft bearing	PTFE+ SS400	PTFE+ SUS316L
	Bottom gasket	#8121 or T#1215-A Expanded graphite (Low temperature : -29°C~200°C V#7020)	
Gland packing	RPTFE (Graphite contained)		
Maximum Temperature Range		FCD450 body: -20°C or over ~ less than 200°C	SCS13A body: -29°C or over ~ less than 200°C
Test pressure	Body Shell	working pressure × 1.5 (Hydraulic pressure)	
	Seat leak	working pressure × 1.1 (Pneumatic pressure)	
Actuators	Lock lever	1T	40 to 150mm (1 1/2 to 6inch)
	Worm gear	2U	40 to 300mm (1 1/2 to 12inch)
		7E	40 to 300mm (1 1/2 to 12inch)
		7F, 7G	40 to 200mm (1 1/2 to 8inch)
	Pneumatic cylinder	3U, 3K	250, 300mm (10, 12inch)
		4I	40 to 300mm (1 1/2 to 12inch)
4J		40 to 300mm (1 1/2 to 12inch)	
Motorized			
Fluid types		Air Gas, Hot air, Water, Chemical solution, Steam	
Surface treatment	Body	FCD450 only : nitriding treatment	
	Disc	Hard chrome plating	
	Seating retainer	SF490A ^{※2} or S25C or S45C : Alkaline blackening	
Coating		FCD450-body only : Modified silicon resin coating (Munsell N7)	

※1. The parts that use properly by body material and specification, please refer to the Following table.

※2. In case of 40mm

Case of SCS body : Material is SCS13A only. (Common parts is 304Y)

Case of FCD body : Material is SF490A only. (Common parts is 304Y)

※ There is possibility of seat leakage when fluid (powder/liquid) is solidified by working temperature and other cause, especially the valve is in a vertical position(e.g. at the bottom area of discharge spout of hopper and tank). Please consult us.

Specification	Body's Material	Temperature range	Parts material			
			Shaft	Seating	Bottom gasket	Grand packing
for Standard	SCS13A	0°C to 200°C	SUS630	RPTFE: (Carbon and graphite contained)	#8121 or T#1215-A	RPTFE: (Graphite contained)
	FCD450		SUS420J2			
for Low Temperature	SCS13A	-29°C to 200°C	SUS630			
	FCD450	-20°C to 200°C	SUS420J2		V#7020	

304YA Expanded view of components

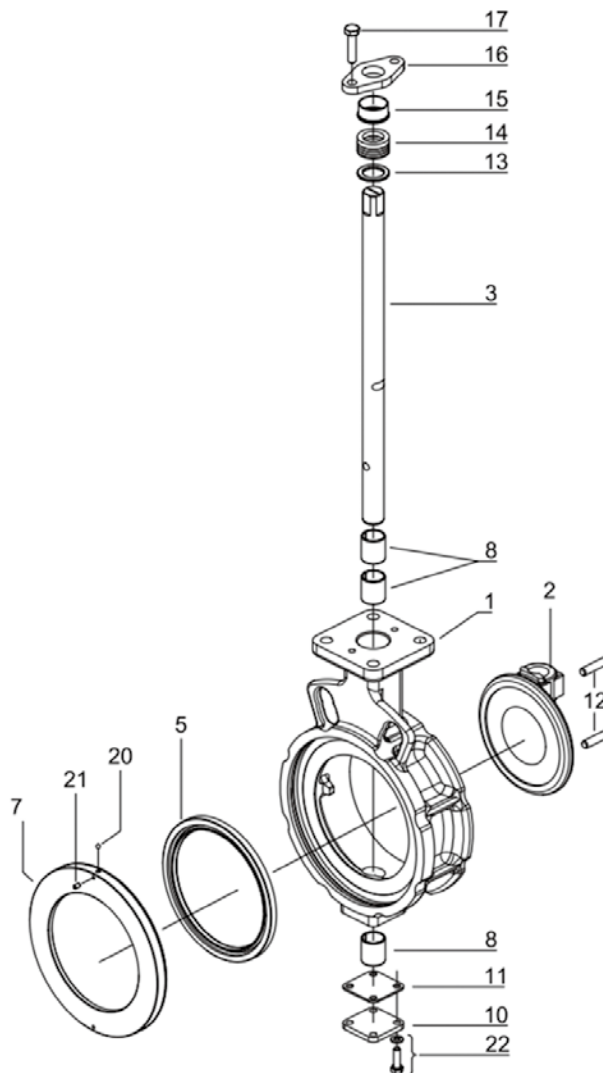

304YA Parts list

304YA Parts list

No.	Description	Q'ty	Remarks
1	Body	1	
2	Disc	1	
3	Shaft	1	
★ 5	Seating ring	1	
7	Seating retainer	1	
8	Shaft bearing	3	
10	Bottom cover	1	
★ 11	Bottom gasket	1	
12	Taper pin	2	
13	Packing retainer	1	
★ 14	Gland packing	1 set	
15	Rough gland	1 set	
16	Gland flange	1	
17	Hxagon bolt	2	
★ 20	Ball	2	40mm to 100mm
		3	125mm to 300mm
★ 21	Hexagon socket set screw	2	40mm to 100mm
		3	125mm to 300mm
22	Hexagon bolt, Spring washer	4	

Remark: The ★ indicates recommended spare parts. They are supplied as "Seat ring set" with a small hexagonal spanner to remove set screws (Part #21 Set screw).

304YA Actuator selection chart

■ 304YA

Model	Size $\left(\frac{\text{mm}}{\text{inch}}\right)$									
	40	50	65	80	100	125	150	200	250	300
	1 1/2	2	2 1/2	3	4	5	6	8	10	12
1T	1T-1					1T-2				
2U	2U-0	2U-1		2U-2			2U-3	2U-4		
7E	T35		T85		T200		T380		T750	
7G,7F	T85S		T200S		T380S	T750S				
3U,3K									TG-12S	
4I	4I-0			4I-1	4I-2		4I-2.5		4I-3	
4J	SRJ-010					SRJ-020	SRJ-060			

304YA Pressure and temperature rating

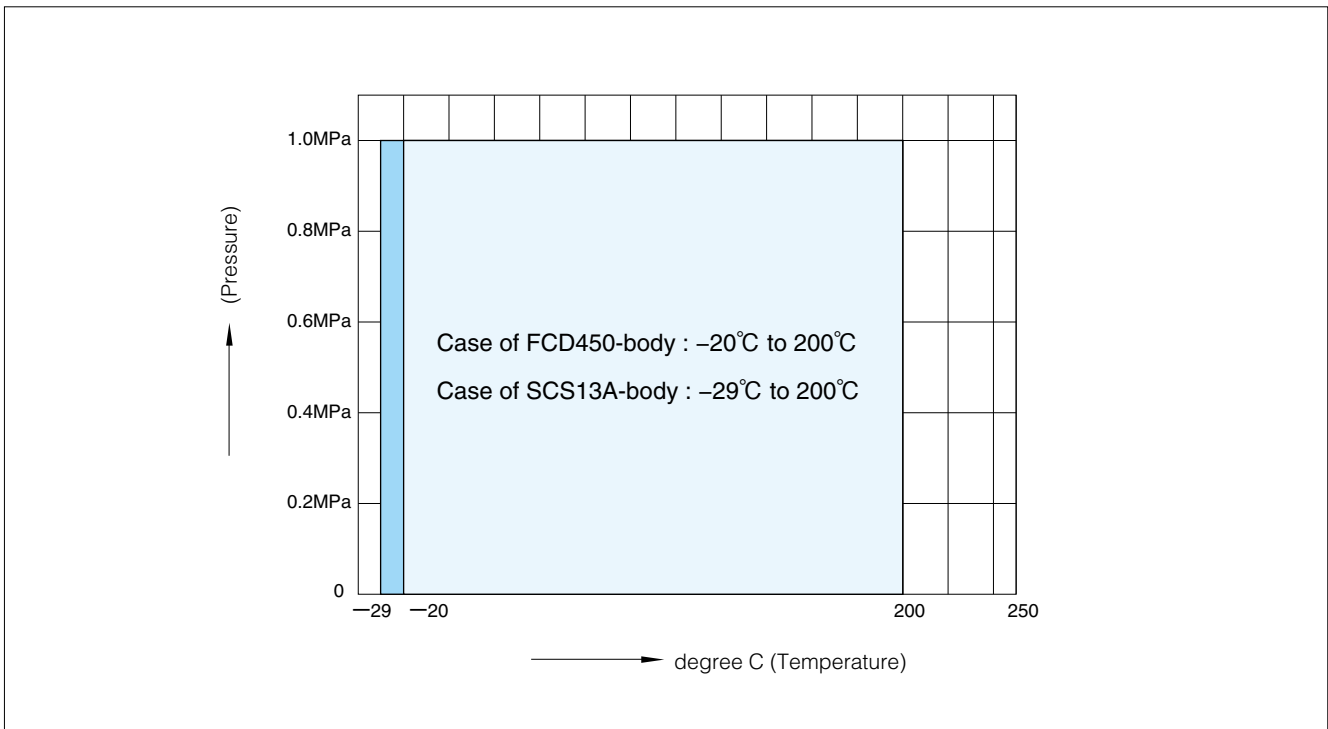

Tom Disco® 304YA

304YA Bare shaft

■304YA-01

Nominal size		Dimension (mm)													Approx. Mass (kg)	
mm	inch	ϕd	ϕD	L	L ₂	H ₁	H ₂	a ₁	a ₂	a ₃	ϕd_2	$\square S_1$	t	Flange type	SCS-body	FCD-body
40	1 1/2	48	81	33	15	57	106	46.5	10.5	36	10	8	11	F07	1.7	1.6
50	2	59	96	43	25.4	67	114	46.5	10.5	36	10	8	11	F07	2.3	2.1
65	2 1/2	73	115	46	27.4	75	125	46.5	10.5	36	12	10	11	F07	3.0	2.8
80	3	87	127	46	24.5	83	132	47.5	11.5	36	14	12	11	F07	3.5	3.2
100	4	109	152	52	28.3	97	147	52.5	16.5	36	16	14	11	F07	4.6	4.3
125	5	137	183	56	30.1	111	166	52.5	16.5	36	18	14	13	F10	7.1	6.7
150	6	163	211	57	28.9	129	181	52.5	16.5	36	20	16	13	F10	8.9	8.4
200	8	213	257	62	30.8	156	212	55	20	35	22	18	13	F10	12.3	11.6
250	10	263	322	70	33.3	184	243	60	30	30	28	24	13	F10	21.0	19.9
300	12	315	367	80	40.8	213	290	63	30	33	30	24	16	F12	28.2	26.8

■304YA-01

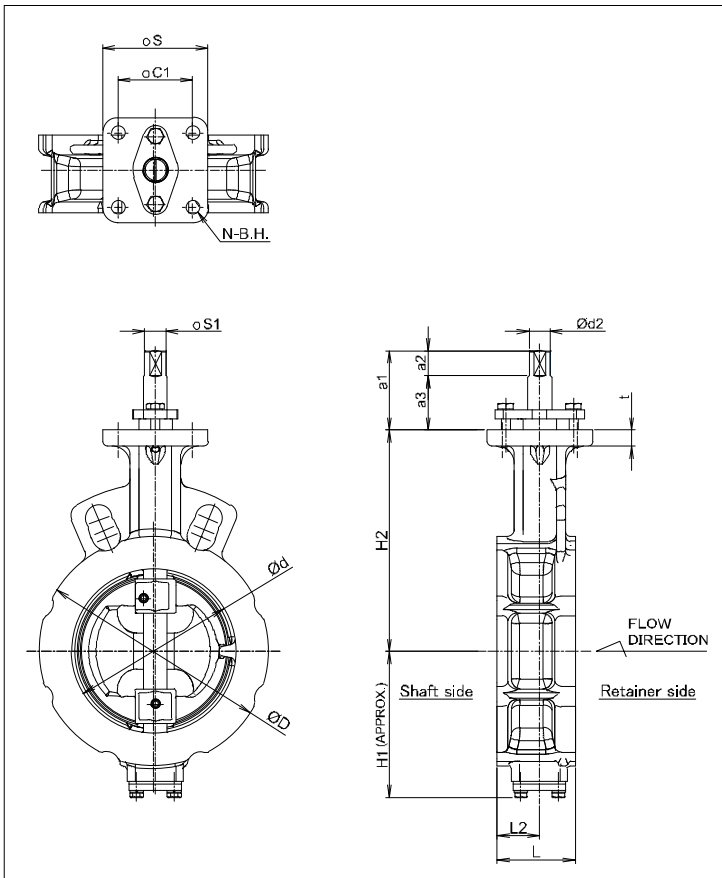

■Top flange

Flange type	$\square S$	ϕC_1	N	B.H.
F07	70	49.5	4	9
F10	102	72.1	4	11
F12	125	88.4	4	13

Lock lever type 304YA-1T (40mm to 150mm)

■ 304YA-1T

Nominal size		Dimension (mm)										Lever type	Approx. Mass (kg)
mm	inch	ϕd	ϕD	L	L ₂	H ₁	H ₂	H ₃	H ₄	Q	W		
40	1 1/2	48	81	33	15	57	106	66	25	75	200	1T-1	2.8
50	2	59	96	43	25.4	67	114	66	25	75	200	1T-1	3.3
65	2 1/2	73	115	46	27.4	75	125	66	25	75	200	1T-1	4.1
80	3	87	127	46	24.5	83	132	66	25	75	200	1T-1	4.5
100	4	109	152	52	28.3	97	147	66	25	75	200	1T-1	5.7
125	5	137	183	56	30.1	111	166	92	25	87.5	300	1T-2	9.3
150	6	163	211	57	28.9	129	181	92	25	87.5	300	1T-2	11.1

■ 304YA-1T

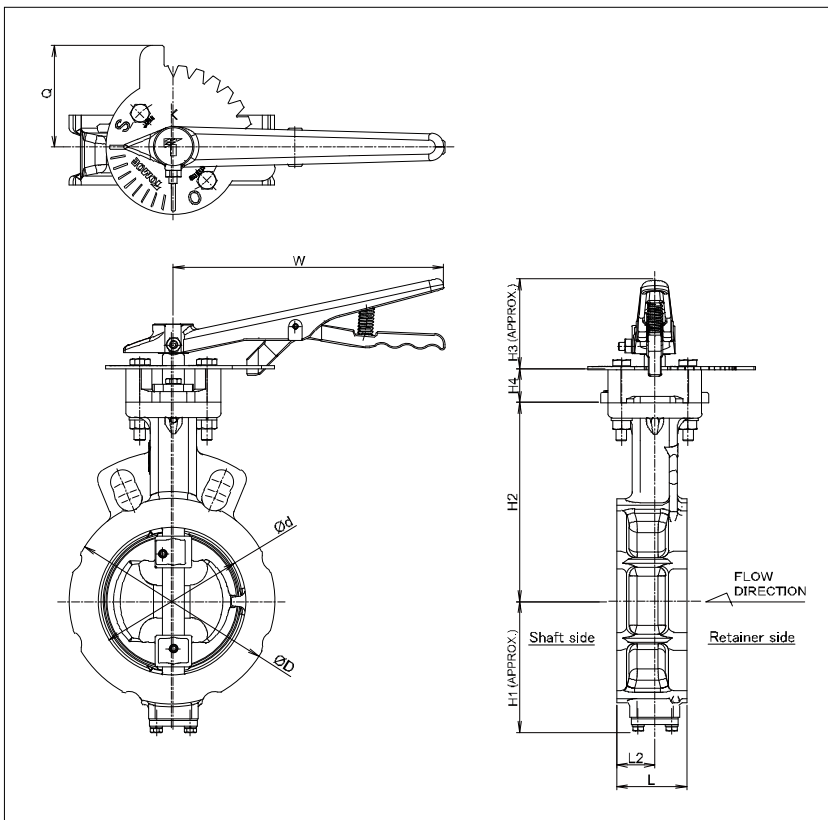

■ 1T Installation direction

<p>Retainer side</p> <p>Flow</p> <p>Shaft side</p> <p>1TA</p>	<p>Retainer side</p> <p>Flow</p> <p>Shaft side</p> <p>1TB</p>	<p>Retainer side</p> <p>Flow</p> <p>Shaft side</p> <p>1TC</p>	<p>Retainer side</p> <p>Flow</p> <p>Shaft side</p> <p>1TD</p>
---	---	---	---

Tom Disco® 304YA

Worm gear type 304YA-2U(40mm to 300mm)

■304YA-2U(40mm to 300mm)

Nominal size		Dimension (mm)												Gear type	Approx. Mass (kg)
mm	inch	ϕd	ϕD	L	L ₂	H ₁	H ₂	H ₃	H ₄	E	K	F	ϕW		
40	1 1/2	48	81	33	15	57	106	29.5	26.5	36	46	160	100	2U-0	4.3
50	2	59	96	43	25.4	67	114	29.5	26.5	36	46	160	100	2U-0	4.9
65	2 1/2	73	115	46	27.4	75	125	29.5	26.5	36	46	160	100	2U-1	5.6
80	3	87	127	46	24.5	83	132	29.5	26.5	36	46	160	100	2U-1	6.1
100	4	109	152	52	28.3	97	147	34.5	26.5	44	53	173.5	160	2U-2	9.1
125	5	137	183	56	30.1	111	166	34.5	26.5	44	53	173.5	160	2U-2	12.0
150	6	163	211	57	28.9	129	181	34.5	26.5	44	53	173.5	160	2U-2	13.8
200	8	213	257	62	30.8	156	212	41.5	26.5	67	75	198	200	2U-3	20.8
250	10	263	322	70	33.3	184	243	41.5	26.5	67	75	198	200	2U-3	29.5
300	12	315	367	80	40.8	213	290	48.0	29.5	87.5	90	222.5	200	2U-4	45.6

■304YA-2U

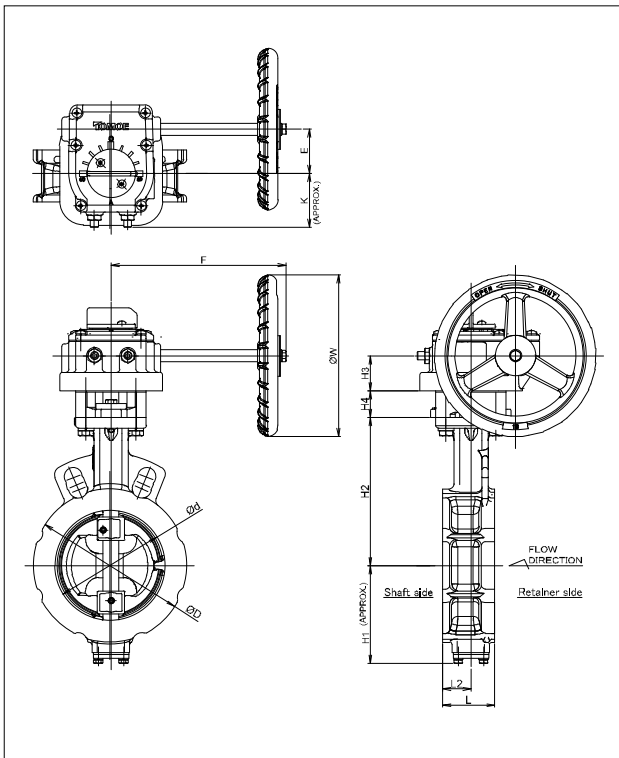

■2U Installation direction

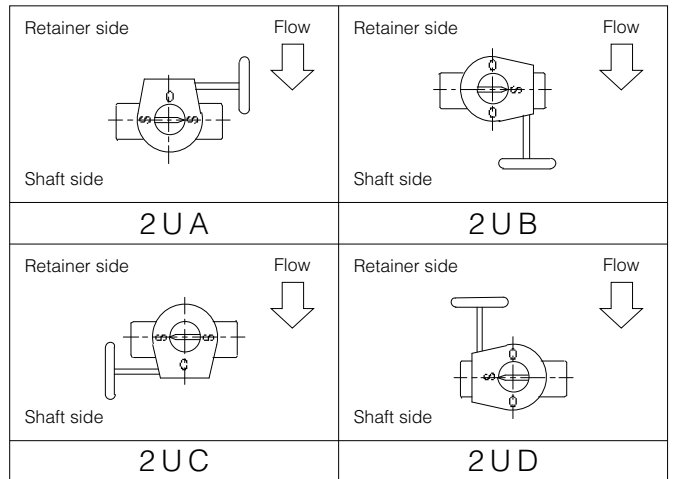

Double-acting pneumatic cylinder type 304YA-7E (40mm to 300mm)

304YA-7E

Nominal size		Dimension (mm)													Cylinder type	Approx. Mass (kg)
mm	inch	ϕd	ϕD	L	L ₂	H ₁	H ₂	H ₃	H ₄	A	P	f ₁	f ₂	f ₃		
40	1 1/2	48	81	33	15	57	106	125	26.5	228	116	57	29	35	T35	3.8
50	2	59	96	43	25.4	67	114	125	26.5	228	116	57	29	35	T35	4.4
65	2 1/2	73	115	46	27.4	75	125	125	26.5	228	116	57	29	35	T35	5.1
80	3	87	127	46	24.5	83	132	168	26.5	276	142	75	47	51	T85	8.5
100	4	109	152	52	28.3	97	147	168	26.5	276	142	75	47	51	T85	9.6
125	5	137	183	56	30.1	111	166	203	26.5	346	176	79	57	51	T200	15.8
150	6	163	211	57	28.9	129	181	203	26.5	346	176	79	57	51	T200	17.6
200	8	213	257	62	30.8	156	212	231	26.5	426	214	91	69	62.5	T380	27.1
250	10	263	322	70	33.3	184	243	231	26.5	426	214	91	69	62.5	T380	35.8
300	12	315	367	80	40.8	213	290	269	29.5	546	270	118	85	70	T750	53.6

304YA-7E

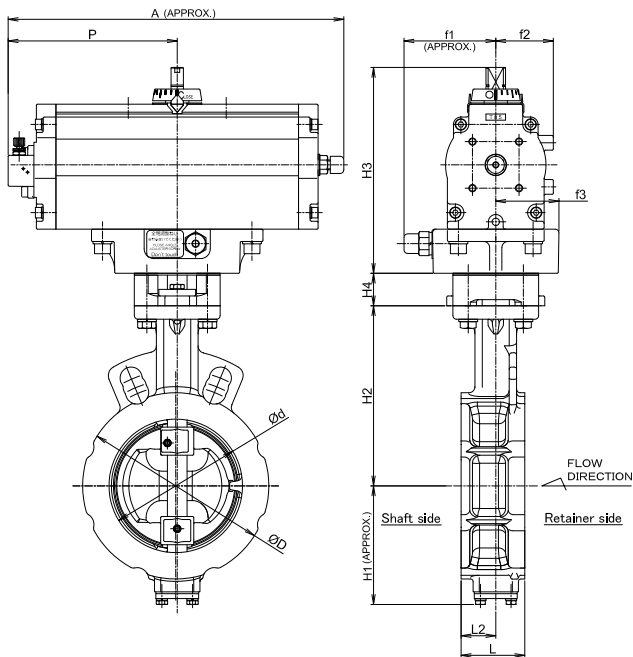

7E Installation direction

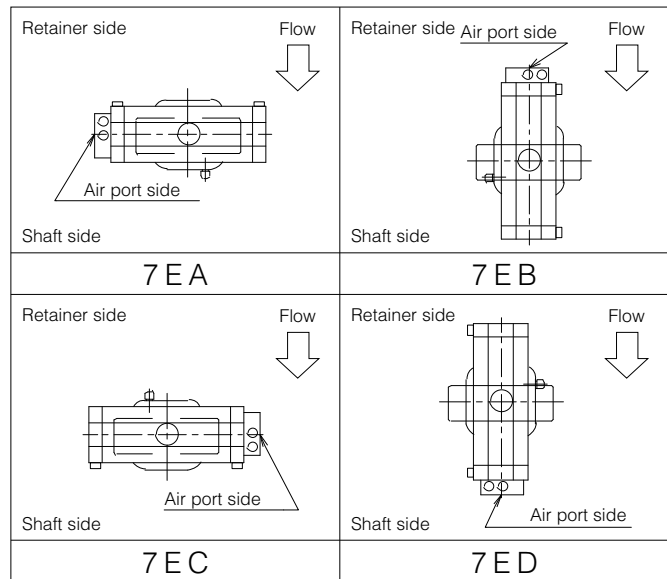

Tom Disco® 304YA

Single-acting pneumatic cylinder type 304YA-7G (Air to open: 40mm to 200mm) / 304YA-7F (Air to close: 40mm to 200mm)

304YA-7G/7F

Nominal size		Dimension (mm)													Cylinder type	Approx. Mass (kg)
mm	inch	ϕd	ϕD	L	L ₂	H ₁	H ₂	H ₃	H ₄	A	P	f ₁	f ₂	f ₃		
40	1 1/2	48	81	33	15	57	106	168	26.5	363.5	182.5	75	47	51	T85S	8.3
50	2	59	96	43	25.4	67	114	168	26.5	363.5	182.5	75	47	51	T85S	8.9
65	2 1/2	73	115	46	27.4	75	125	168	26.5	363.5	182.5	75	47	51	T85S	9.6
80	3	87	127	46	24.5	83	132	203	26.5	448.5	225.5	79	57	51	T200S	14.6
100	4	109	152	52	28.3	97	147	203	26.5	448.5	225.5	79	57	51	T200S	15.7
125	5	137	183	56	30.1	111	166	231	26.5	549.5	276	91	69	62.5	T380S	26.8
150	6	163	211	57	28.9	129	181	269	26.5	722.5	359.5	118	85	70	T750S	42.1
200	8	213	257	62	30.8	156	212	269	26.5	722.5	359.5	118	85	70	T750S	45.5

304YA-7G/7F

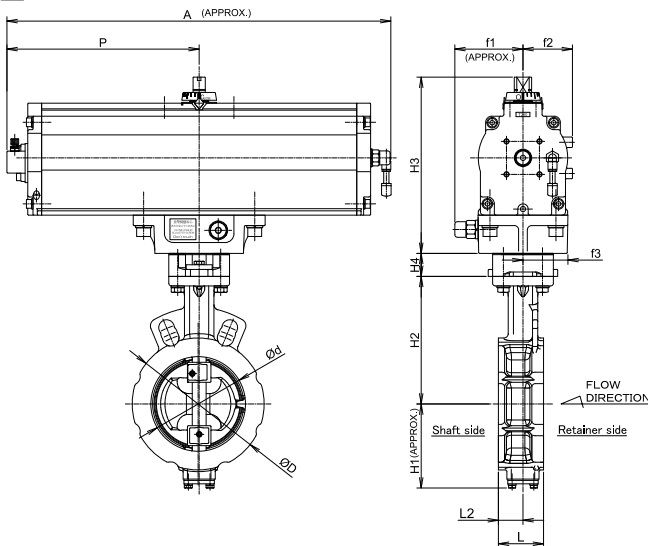

7G/7F Installation direction

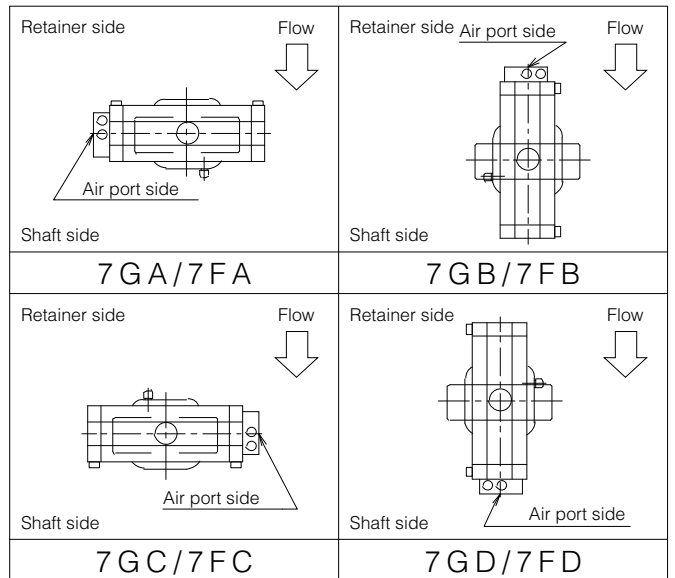

Single-acting pneumatic cylinder type 304YA-3U (Air to open: 250mm to 300mm) / 304YA-3K (Air to close: 250mm to 300mm)

■ 304YA-3U/3K

Nominal size		Dimension (mm)													Cylinder type	Approx. Mass (kg)
mm	inch	ϕd	ϕD	L	L ₂	H ₁	H ₂	H ₃	H ₄	A	P	B	f ₁	f ₂		
250	10	263	322	70	33.3	184	243	277	100	1080	720	60	94	206	TG-12S	122
300	12	315	367	80	40.8	213	290	277	100	1080	720	60	94	206	TG-12S	130

■ 304YA-3U

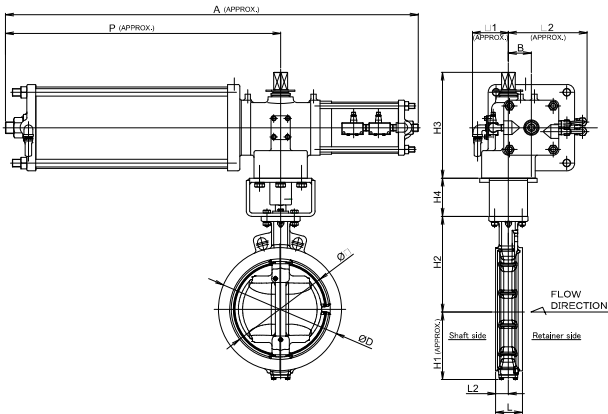

■ 304YA-3K

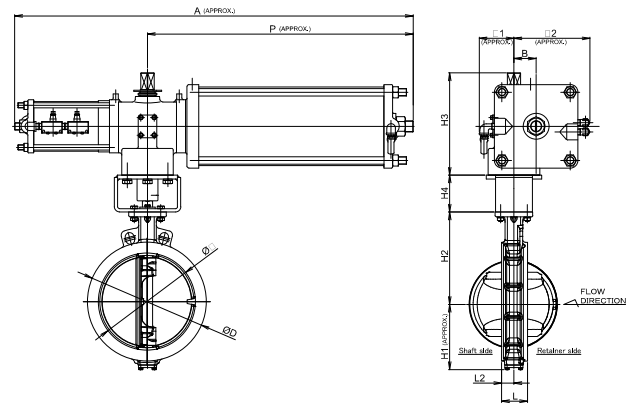

■ 3U Installation direction

<p>Retainer side</p> <p>Flow</p> <p>Shaft side</p> <p>3 U A</p>	<p>Retainer side</p> <p>Flow</p> <p>Shaft side</p> <p>3 U B</p>	<p>Retainer side</p> <p>Flow</p> <p>Shaft side</p> <p>3 U C</p>	<p>Retainer side</p> <p>Flow</p> <p>Shaft side</p> <p>3 U D</p>
---	---	---	---

■ 3K Installation direction

<p>Retainer side</p> <p>Flow</p> <p>Shaft side</p> <p>3 K A</p>	<p>Retainer side</p> <p>Flow</p> <p>Shaft side</p> <p>3 K B</p>	<p>Retainer side</p> <p>Flow</p> <p>Shaft side</p> <p>3 K C</p>	<p>Retainer side</p> <p>Flow</p> <p>Shaft side</p> <p>3 K D</p>
---	---	---	---

Tom Disco® 304YA

Single phase electric motor type 304YA-4 I (40mm to 300mm)

■304YA-4 I

Nominal size		Dimension (mm)															Motor type	Approx. Mass (kg)
mm	inch	ϕd	ϕD	L	L ₂	H ₁	H ₂	H ₃	H ₄	H ₅	A ₁	A ₂	F	K	E	ϕW		
40	1 1/2	48	81	33	15	57	106	150	100	100	100	102	85	53.8	43	—	NEL-0	9.3
50	2	59	96	43	25.4	67	114	150	100	100	100	102	85	53.8	43	—	NEL-0	9.9
65	2 1/2	73	115	46	27.4	75	125	150	100	100	100	102	85	53.8	43	—	NEL-0	10.6
80	3	87	127	46	24.5	83	132	150	100	100	100	102	85	53.8	43	—	NEL-0	11.1
100	4	109	152	52	28.3	97	147	165	100	100	138	114	126	65	12	70	NEL-1	14.4
125	5	137	183	56	30.1	111	166	198	100	100	167	143	154	85	14	100	NEL-2	22.3
150	6	163	211	57	28.9	129	181	198	100	100	167	143	154	85	14	100	NEL-2	24.6
200	8	213	257	62	30.8	156	212	198	175	100	167	143	154	85	14	100	NEL-2.5	33.6
250	10	263	322	70	33.3	184	243	198	175	100	167	143	154	85	14	100	NEL-2.5	42.3
300	12	315	367	80	40.8	213	290	230	175	100	223	98.5	245.5	136	22.5	200	NEL-3	59.9

■304YA-4 I

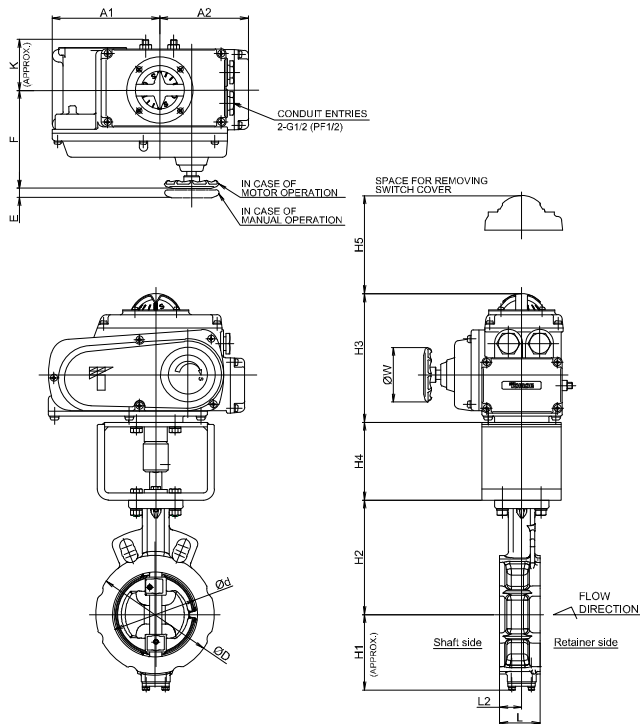

■4I Installation direction

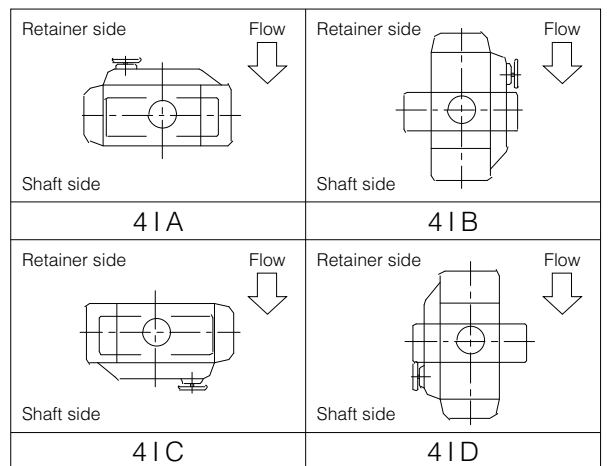

Three phase motor actuator type 304YA-4J(40mm to 300mm)

■304YA-4J

Nominal size		Dimension (mm)							Motor type			Approx. Mass (kg)
mm	inch	ϕd	ϕD	L	L ₂	H ₁	H ₂	H ₄	Model	90° Control time(sec) (50/60Hz)		
40	1 1/2	48	81	33	15	57	106	103	SRJ-010_40W	9 / 7.5	18 / 15	18.2
50	2	59	96	43	25.4	67	114	103	SRJ-010_40W	9 / 7.5	18 / 15	18.8
65	2 1/2	73	115	46	27.4	75	125	103	SRJ-010_40W	9 / 7.5	18 / 15	19.5
80	3	87	127	46	24.5	83	132	103	SRJ-010_40W	9 / 7.5	18 / 15	20.0
100	4	109	152	52	28.3	97	147	103	SRJ-010_40W	9 / 7.5	18 / 15	21.1
125	5	137	183	56	30.1	111	166	103	SRJ-010_40W	9 / 7.5	18 / 15	23.6
150	6	163	211	57	28.9	129	181	180	SRJ-020_40W	18 / 15	36 / 30	28.9
200	8	213	257	62	30.8	156	212	180	SRJ-060_100W	18 / 15	36 / 30	39.3
250	10	263	322	70	33.3	184	243	180	SRJ-060_100W	18 / 15	36 / 30	48.0
300	12	315	367	80	40.8	213	290	180	SRJ-060_100W	18 / 15	36 / 30	55.2

■304YA-4J
40 to 150mm

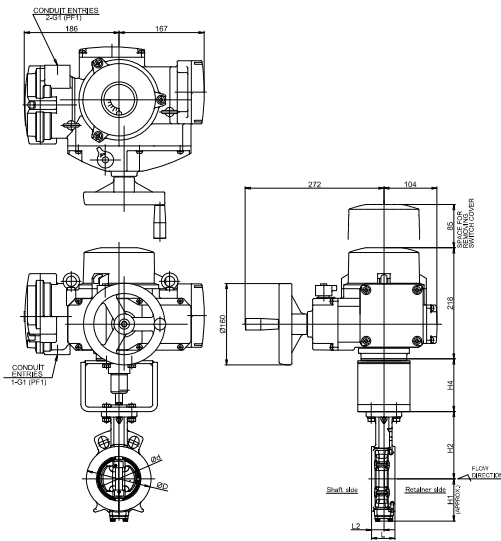

■304YA-4J
200 to 300mm

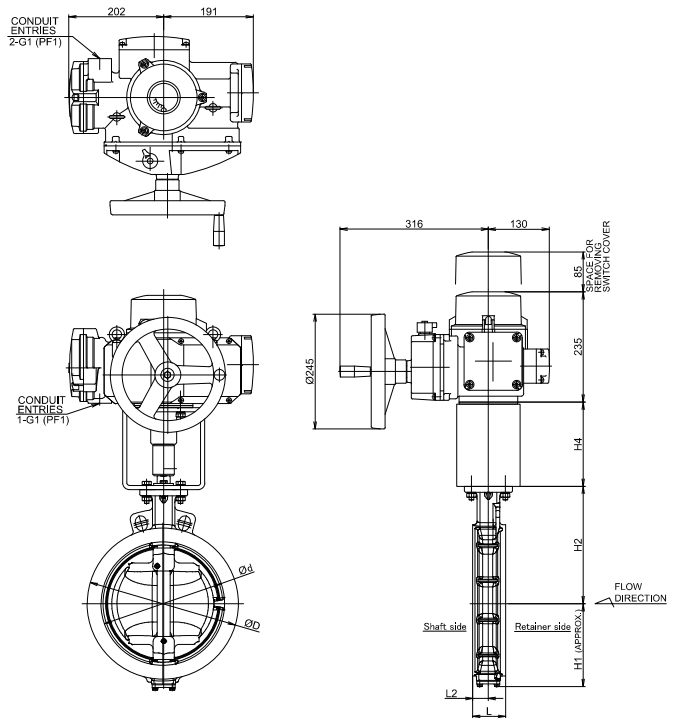

■4J Installation direction

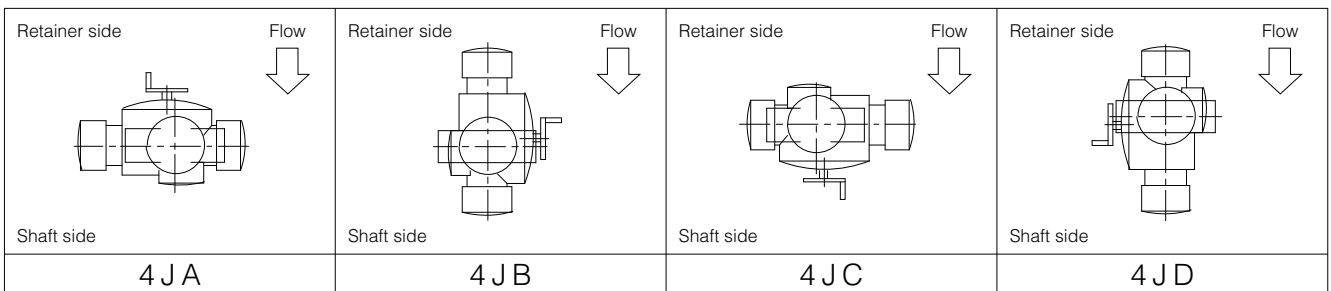

304YA Cv value/pressure loss coefficient

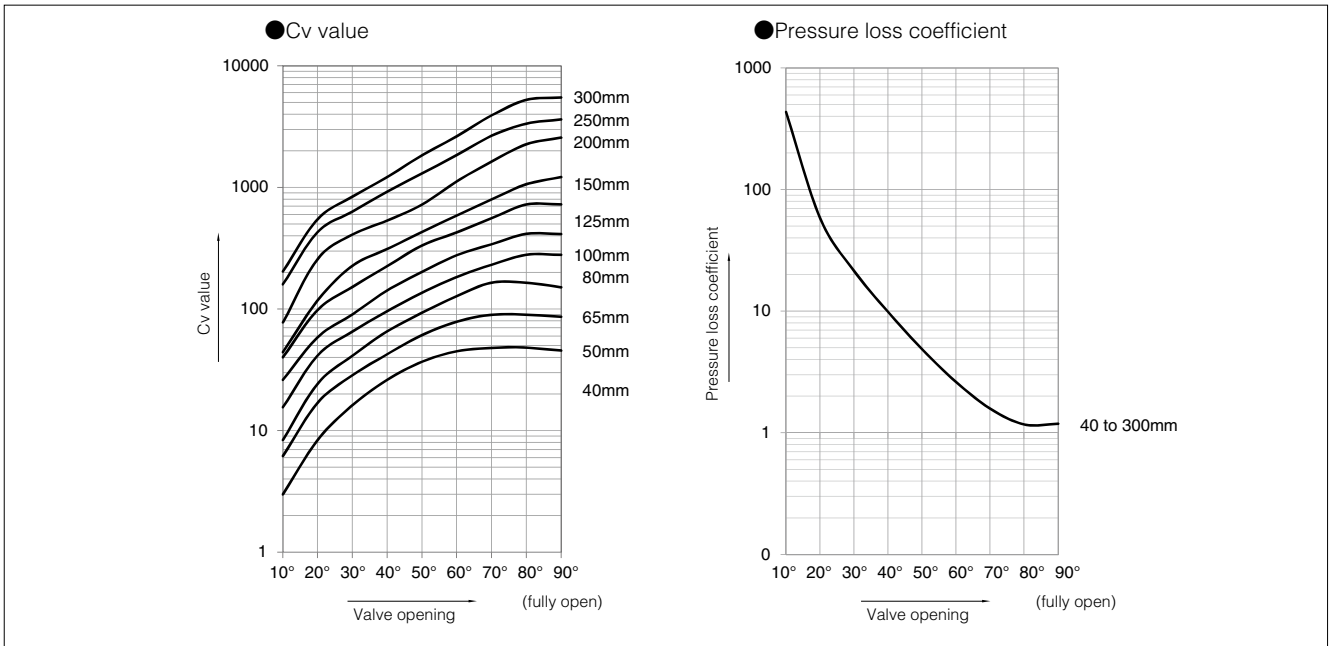

304YA Cv value

Nominal size		Valve opening								
mm	inch	10°	20°	30°	40°	50°	60°	70°	80°	90°
40	1 1/2	3	8	16	26	37	45	48	48	46
50	2	6	17	29	43	61	79	90	90	87
65	2 1/2	8	24	41	66	93	128	165	165	151
80	3	16	42	65	96	137	184	232	280	280
100	4	26	59	91	142	202	277	342	416	414
125	5	40	99	152	226	334	428	559	725	725
150	6	44	118	227	312	431	589	799	1065	1219
200	8	78	259	410	535	725	1123	1632	2272	2570
250	10	160	431	634	926	1306	1848	2662	3352	3628
300	12	204	550	840	1220	1840	2636	3920	5260	5498

304YA Pressure loss coefficient

Nominal size		Valve opening								
mm	inch	10°	20°	30°	40°	50°	60°	70°	80°	90°
40	1 1/2	608	78	21	8	4	3	2	2	3
50	2	348	46	16	7	4	2	2	2	2
65	2 1/2	541	64	22	9	4	2	1	1	2
80	3	360	51	20	10	5	3	2	1	1
100	4	311	62	26	11	5	3	2	1	1
125	5	323	54	23	10	5	3	2	1	1
150	6	554	77	21	11	6	3	2	1	1
200	8	565	51	20	12	7	3	1	1	1
250	10	326	45	21	10	5	2	1	1	1
300	12	416	57	25	12	5	2	1	1	1

304YA Applicable pipe list in case of **A**, **B**

Figure A

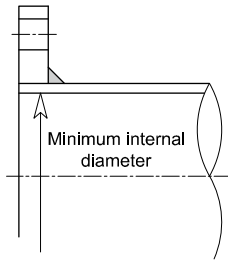
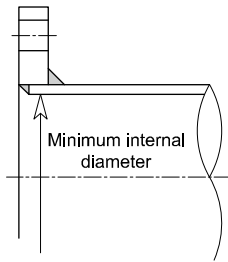

Figure B



Nominal size		JISG3452	JISG3454		JISG3459 (Stainless)	
mm	inch	SGP	Sch20	Sch40	Sch10S	Sch20S
40	1 1/2	○	—	○	○	○
50	2	○	○	○	○	○
65	2 1/2	○	○	○	○	○
80	3	○	○	○	○	○
100	4	○	○	○	○	○
125	5	○	○	○	○	○
150	6	○	○	○	○	○
200	8	○	○	○	○	○
250	10	○	○	○	○	○
300	12	○	○	○	○	○

Remark 1: ○=Applicable ×=Not applicable

304YA Piping gasket

- In case of sheet gasket Any standard can be used excluding 65mm-JIS flange. For 65mm-JIS flange, use the sheet gasket that followed old JIS Standard: JIS B 2404_1999 for inner diameter. For other size, JIS standard products can be used.
- In case of spiral gasket Use special spiral gasket shown below.

■ Special spiral gasket

Nominal size		JIS 10K				ASME Class 150			
mm	inch	D ₁	D ₂	D ₃	D ₄	D ₁	D ₂	D ₃	D ₄
40	1 1/2	48	54	73	89	48	54	73	85
50	2	61	69	88	104	61	69	88	104
65	2 1/2	73	81	100	124	73	81	100	123
80	3	89	97	120	134	89	97	120	136
100	4	115	124	146	159	115	124	146	174
125	5	140	151	177	190	140	151	177	196
150	6	166	178	207	220	166	178	207	222
200	8	217	227	257	270	217	229	257	279
250	10	268	282	318	332	268	285	318	333
300	12	319	331	362	377	319	335	362	409

Remark : In case a minute leakage of gas (less than 100PPm) becomes a problem, please consult to engineers.

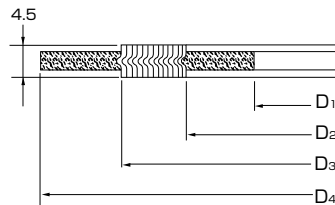

■ Available punching gasket and PTFE envelope gasket

Nominal size		Max. allowable inner diameter	Joint sheet and PTFE punching gasket (t≤2mm)			PTFE mold type gasket (NIPPON VALQUA products: 7030, 7031, 7035 series)		
mm	inch		D	JIS 5K	JIS 10K	ASME Class 150	JIS 5K	JIS 10K
40	1 1/2	55	○	○	○	○	○	○
50	2	69	○	○	○	○	○	○
65	2 1/2	77	×	×	○	×	×	○
80	3	97	○	○	○	○	○	○
100	4	124	○	○	○	○	○	○
125	5	151	○	○	○	○	○	○
150	6	178	○	○	○	○	○	○
200	8	227	○	○	○	○	○	○
250	10	282	○	○	○	○	○	○
300	12	331	○	○	○	○	○	○

Remarks : The above gaskets is not applicable to JIS piping 65mm. When using a gasket for JIS piping 65mm, make sure that the inner diameter of the gasket is 77 mm. PTFE mold type gasket made by NIPPON VALQUA is only available. (Other manufacturer's gasket is not applicable due to product size.)

304YA Flange accommodation

Nominal size		JIS		ASME B16.1 ASME B16.5		BS4504 DIN2632,DIN2633 GB/T9113.1	
mm	inch	5K	10K	Class125	Class150	PN10 PN1.0	PN16 PN1.6
40	1 1/2	○	○	○	○	○	△
50	2	○	○	○	○	○	△
65	2 1/2	○	○	○	○	○	△
80	3	○	○	○	○	○	○
100	4	○	○	○	○	○	○
125	5	○	○	○	○	○	○
150	6	○	○	○	○	○	○
200	8	○	○	○	○	○	○
250	10	○	○	○	○	○	△
300	12	○	○	○	○	○	○

○ : Possible to connect.

△ : Allows connection by additional machining.

304YA Piping bolts and nuts sizes

Nominal size		JIS 5K	JIS 10K	ASME Class 150
mm	inch			
40	1 1/2	4-M12×100×12	4-M16×120×16	4-U1/2×115×16
50	2	4-M12×120×12	4-M16×130×16	4-U5/8×140×16
65	2 1/2	4-M12×120×12	4-M16×145×16	4-U5/8×155×16
80	3	4-M16×130×16	8-M16×145×16	4-U5/8×155×20
100	4	8-M16×145×16	8-M16×145×16	8-U5/8×155×20
125	5	8-M16×145×16	8-M20×170×20	8-U3/4×175×22
150	6	8-M16×145×16	8-M20×170×20	8-U3/4×175×22
200	8	8-M20×170×20	12-M20×170×20	8-U3/4×205×22
250	10	12-M20×190×20	12-M22×190×22	12-U7/8×215×24
300	12	12-M20×190×20	16-M22×190×22	12-U7/8×215×24

Remark: Bolt / nut material: SNB7 / S45C (manufacturer standard product), SUS304 / SUS304 (order-made product) Spiral gasket cannot be used. Use full-thread bolts for long bolts and heavy nuts for hexagon nuts.

Example

Long bolts: 8 - M16 × 145 × 16

N
M
L
H

